



NetScaler SDX

Contents

NetScaler SDX hardware-software compatibility matrix	3
SDX hardware platforms	6
NetScaler SDX 8900	7
NetScaler SDX 9100	9
NetScaler SDX 14000	11
NetScaler SDX 14000-40G	13
NetScaler SDX 14xxx-40S	15
NetScaler SDX 14030 FIPS, 14060 FIPS, 14080 FIPS	16
NetScaler SDX 15000	18
NetScaler SDX 15000-50G	20
NetScaler SDX 16000	23
NetScaler SDX 25100A, SDX 25160A	26
NetScaler SDX 25100-40G	27
NetScaler SDX 26000	30
NetScaler SDX 26000-50S	32
NetScaler SDX 26000-100G	34
Common hardware components	37
Field replaceable units	48
Safety, cautions, warnings, and other information	54
Prepare for installation	55
Install the hardware	57
Initial configuration	67
Lights out management port of the NetScaler SDX appliance	72

Configure the network settings on the LOM port	74
Create and install an SSL certificate on SDX 9100 and SDX 16000	79
Install a certificate and key on older platforms using the LOM GUI	84
Obtaining the MAC address, serial number, and host properties of the appliance	90
Perform power control operations by using the LOM port	91
Restoring the BMC configuration to factory defaults	93
Specifying the port for IPMI BMC failover	94
Using the BIOS POST code to detect errors	94
Hardware health attributes of NetScaler SDX appliances	95
Hardware health attributes for the SDX 16000 platform	103
Fortville NIC firmware upgrade on NetScaler SDX appliances	108
Converting a NetScaler MPX appliance to a NetScaler SDX appliance	110
Convert a NetScaler MPX 26000-50S appliance to a NetScaler SDX 26000-50S appliance	111
Converting a NetScaler MPX 24100 and 24150 appliance to a NetScaler SDX 24100 and 24150 appliance	130
Convert a NetScaler MPX 14020/14030/14040/ 14060/14080/14100 appliance to a NetScaler SDX 14020/14030/14040/ 14060/14080/14100 appliance	133
Convert a NetScaler MPX 14020 40G, MPX 14040 40G, MPX 14060 40G, MPX 14080 40G appliance to a NetScaler SDX 14020 40G, SDX 14040 40G, SDX 14060 40G, SDX 14080 40G appliance	141
Convert a NetScaler MPX 8900 appliance to a NetScaler SDX 8900 appliance	157
Convert a NetScaler MPX 15000 appliance to a NetScaler SDX 15000 appliance	166
Migrate the configuration of a NetScaler instance across SDX appliances	183
Troubleshooting	189

NetScaler SDX hardware-software compatibility matrix

December 31, 2023

Keep the following points in mind about NetScaler SDX hardware-software and feature-software compatibility:

- For each platform, only the starting build for each release is mentioned. All subsequent builds within a release are supported.
- In 10.5 and prior releases, the SDX appliance was shipped with a virtual bundle. The bundle included a specific combination of Management Service image, Citrix Hypervisor image, Citrix Hypervisor supplemental packs.
- From 11.0 and later releases, the single bundle image is shipped, which combines all the components.
- Any combinations of SDX image version and VPX image versions are supported as long as they meet minimum version requirements for a particular hardware platform.
- From 12.0 57.19, the single bundle image also includes the lights-out management (LOM) firmware.
- Direct upgrade from version 10.5 to version 13.1 is not supported. First upgrade from 10.5 to 11.1 or 12.0 or 12.1, and then upgrade to SDX 13.1.
- Usually, the SDX image and the VPX image are not interdependent, which means the SDX appliance and the VPX instances don't need the same image version.

Exception: If you provision a new VPX instance or upgrade an existing VPX instance to 12.0-58.15, you must also upgrade the SDX version to 12.0-58.15. See <https://support.citrix.com/article/CTX236730>.

If you use NetScaler ADM to manage NetScaler appliances running 12.0–58.15, you must upgrade NetScaler ADM to 12.0-58.15.

The following tables list the compatibility matrix for all NetScaler SDX hardware platforms and the SDX and VPX images supported on these platforms.

How to read the table

The SDX image version and the VPX image version are listed for each platform. The SDX image and the VPX image are not interdependent, which means the SDX appliance and the VPX instances don't need the same image version. Check the note for exception to compatibility.

IMPORTANT

The first supported build for each hardware platform and software release are listed in the following table. **All subsequent builds are supported unless the word “only” follows the build number. When it does, only the specified build is supported on that platform.**

Hardware platform-s/SDX SBI version and VPX image version	11.1	12.1	13.0	13.1	14.1
SDX 8015	11.1–47.14	12.1–48.13	13.0–36.x	13.1–4.x	14.1–4.x
SDX 8400/8600	11.1–47.14	12.1–48.13	13.0–36.x	13.1–4.x	14.1–4.x
SDX 8920/8930	11.1–57.11 (See note after the table)	12.1–48.13	13.0–36.x	13.1–4.x	14.1–4.x
SDX 9100	X	X	X	13.1–21.50	14.1–4.x
SDX 11500/13500/14500/16500/18500/20500	11.1–47.14	12.1–48.13	13.0–36.x	13.1–4.x	X
SDX 11515/11520/11530/11540/11542	11.1–47.14	12.1–48.13	13.0–36.x	13.1–4.x	X
SDX 14020/14030/14040/14060/14080/14100	11.1–47.14	12.1–48.13	13.0–36.x	13.1–4.x	14.1–4.x
SDX 14020-40G/14040-40G/14060-40G/14080-40G/14100-40G	11.1–47.14	12.1–48.13	13.0–36.x	13.1–4.x	14.1–4.x
SDX 14040-40S/14060-40S/14080-40S/14100-40S	11.1–48.10	12.1–48.13	13.0–36.x	13.1–4.x	14.1–4.x

Hardware platform-s/SDX SBI version and VPX image version	11.1	12.1	13.0	13.1	14.1
SDX 14030 FIPS/14060 FIPS/14080 FIPS	11.1–52.13	12.1–48.13	13.0–36.x	13.1–4.x	14.1–4.x
SDX 15020/15030/15040/15060/15080/15100/15120	11.1–63.x	12.1–56.x	13.0–52.x	13.1–4.x	14.1–4.x
SDX 15020-50G/15030-50G/15040-50G/15060-50G/15080-50G/15100-50G/15120-50G	11.1–59.10	12.1–48.13	13.0–36.x	13.1–4.x	14.1–4.x
SDX 16000	X	X	X	13.1–37.x	14.1–4.x
SDX 22040/22060/22080/22100/22120	11.1–47.14	12.1–48.13	13.0–36.x	13.1–4.x	14.1–4.x
SDX 24100/24150	11.1–47.14	12.1–48.13	13.0–36.x	13.1–4.x	14.1–4.x
SDX 25100A/25160A/25200A	11.1–51.21	12.1–48.13	13.0–36.x	13.1–4.x	14.1–4.x
SDX 25100-40G/25160-40G/25200-40G	11.1–51.21	12.1–48.13	13.0–36.x	13.1–4.x	14.1–4.x
SDX 26100/26160/26200	11.1–63.9	12.1–56.x	13.0–52.x	13.1–4.x	14.1–4.x
SDX 26100-100G/26160-100G/26200-100G	11.1–58.13	12.1–48.13	13.0–36.x	13.1–4.x	14.1–4.x

Hardware platform-s/SDX SBI version and VPX image version	11.1	12.1	13.0	13.1	14.1
SDX 26100-50S/26160-50S/26200-50S	11.1–63.9	12.1–56.x	13.0–52.x	13.1–4.x	14.1–4.x

Notes:

- On the NetScaler SDX 8900 appliance, the 11.1 56.15 VPX image is supported. SDX 11.1 56.15 image is not supported.
- NetScaler Secure Web Gateway (SWG) is supported from release 12.0 56.20 and later.
- NetScaler cluster is not supported on NetScaler SDX SWG instances.

Related information

For information about how to upgrade the NetScaler SDX appliance and the VPX instance, see the following topics.

- [Single bundle upgrade for 12.1 release](#)
- [Demystifying the NetScaler SDX appliance upgrade process](#)

SDX hardware platforms

June 20, 2024

The various NetScaler hardware platforms offer a wide range of features, communication ports, and processing capacities. All platforms have multicore processors.

The NetScaler SDX appliance is a multitenant platform on which you can provision and manage multiple virtual instances. All NetScaler appliances have front to rear airflow.

For the updated list of current platforms, click [Product matrix](#) and select **Citrix ADC**.

NetScaler SDX 8900

December 31, 2023

The NetScaler SDX 8900 appliance is a 1U appliance. This platform has a single 8-core processor and 32 GB of memory. The appliance provides a total of 10 network ports:

- Six 10/100/1000Base-T RJ45 copper Ethernet Ports.
- Four 10G SFP+ Ethernet Ports.

1G copper transceivers are supported in 10G slots. 1G fiber transceivers are not supported.

The appliance comes with two VPX instances and supports up to seven instances. You can separately buy extra five instances.

For information on the software releases supported on the NetScaler hardware platforms, see [NetScaler SDX Hardware-Software Compatibility Matrix](#).

The figures are for illustrative purposes only.

Figure 1. NetScaler SDX 8900 front panel

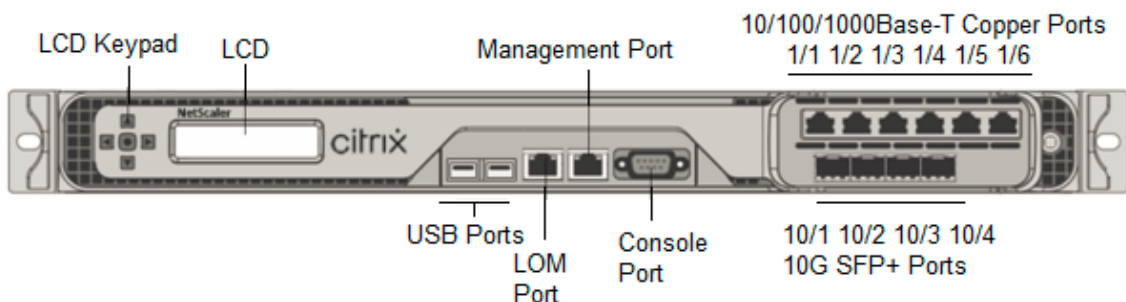

The NetScaler SDX 8900 appliances have the following ports:

- RS232 serial Console Port.
- One 10/100/1000Base-T RJ45 copper Ethernet LOM Port. Use this port to remotely monitor and manage the appliance independently of the NetScaler software.
- One 10/100/1000Base-T RJ45 copper Ethernet Management Port, numbered 0/1. This port is used to connect directly to the appliance for NetScaler administration functions.
- Six 10/100/1000Base-T RJ45 copper Ethernet Ports, numbered 1/1 to 1/6 from left to right.
- Four 10G SFP+ Ethernet Ports, numbered 10/1 to 10/4 from left to right.
- USB port (reserved for a future release).

Figure 2. NetScaler SDX 8900 back panel

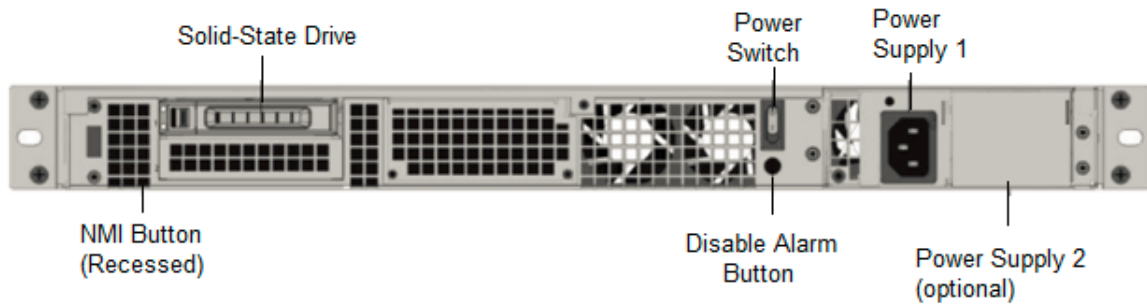

The following components are visible on the back panel of the SDX 8900 appliances:

- One 240 GB or larger removable solid-state drive (SSD).
 - Note:** Drive densities might increase as components become EOL but its size is never smaller than the original.
- Power switch, which turns power to the appliance on or off.
 - If the OS is functional, press the switch for less than two seconds to power down the system with a graceful shutdown.
 - If the OS is not responsive, press the power switch for more than 4 seconds to force the power off.
- One power supply, 100–240 VAC (second power supply for redundancy is a customer installable option). Each power supply has an LED indicating its status:

LED color	LED indicates
OFF	No power to any power supply in the appliance.
Flashing RED	No power to this power supply.
Flashing GREEN	Power supply is in standby mode.
GREEN	Power supply is functional.
RED	Power supply failure.

- **Disable alarm button**, which is functional only when the appliance has two power supplies. Press this button to silence the power alarm when one of two power supplies loses input power (second power supply optional) or when a power supply is malfunctioning.
- Non-Maskable Interrupt (NMI) Button, used at the request of Technical Support to initiate a core dump. To press this red button, which is recessed to prevent unintentional activation, use a pen, pencil, or other pointed object. The **NMI** Button is also available remotely over the network in the LOM GUI, in the **Remote Control** menu. For more information, see [Lights out management port of the NetScaler SDX appliance](#).

NetScaler SDX 9100

January 12, 2024

The NetScaler SDX 9100 appliance is a 1U appliance. This platform has a single 10-core processor and 64 GB of memory. The appliance provides a total of eight 25G SFP28 ports.

For information on the software releases supported on the ADC hardware platforms, see [Hardware-Software Release Matrix](#).

The following figure shows the front panel of the SDX 9100 appliance.

Figure 1. NetScaler SDX 9100, front panel

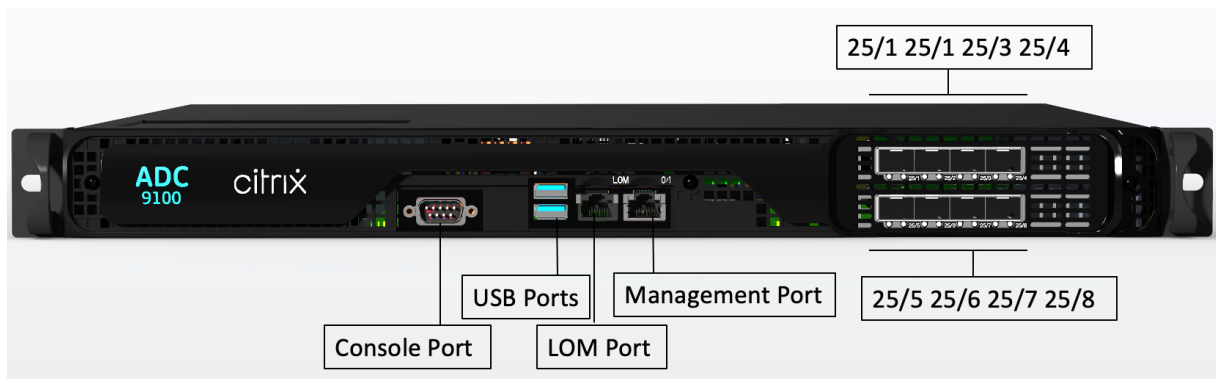

The NetScaler SDX 9100 series appliances have the following ports:

- RS232 serial Console port.
- One 10/100/1000Base-T RJ45 copper Ethernet LOM port. Use this port to remotely monitor and manage the appliance independently of the ADC software.
- One 10/100/1000Base-T RJ45 copper Ethernet management port, numbered 0/1. This port is used to connect directly to the appliance for ADC administration functions.
- Two USB ports (reserved for a future release).
- Eight 25G SFP28 ports, numbered 25/1 to 25/8. For information about supported transceivers per port, see [25G, 40G, 50G, and 100G ports](#).

The following figure shows the back panel of the SDX 9100 appliance.

Figure 2. NetScaler SDX 9100, back panel

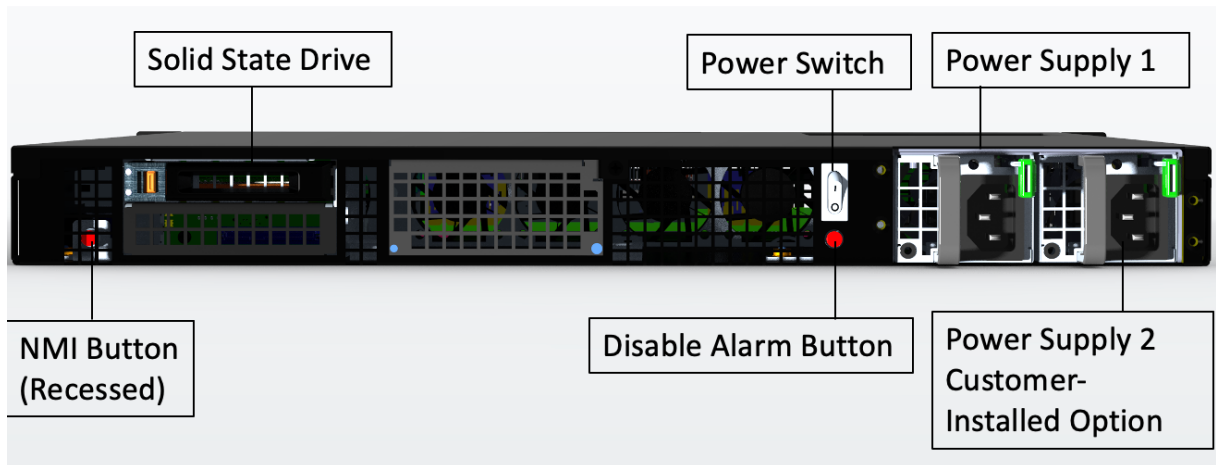

The following components are visible on the back panel of the SDX 9100 appliance:

- One 480 GB removable solid-state drive (SSD).
 - Note:** Drive densities might increase as components become EOL but its size is never smaller than the original.
- Power switch, which turns power to the appliance on or off.
 - If the OS is functional, press the switch for less than two seconds to power down the system with a graceful shutdown.
 - If the OS is not responsive, press the power switch for more than 4 seconds to force the power off.
- Two power supplies (for hardware shipped after 13th Dec, 2023), rated at 450 watts, 100–240 VAC. Maximum power consumption is 275 watts and typical power consumption is 225 watts. The following table indicates the LED status of each power supply:

LED Color	LED Indicates
OFF	No power to any power supply in the appliance.
Flashing RED	No power to this power supply.
Flashing GREEN	Power supply is in standby mode.
GREEN	Power supply is functional.
RED	Power supply failure.

- **Disable alarm button**, which is functional only when the appliance has two power supplies. Press this button to silence the power alarm when one of two power supplies loses input power (second power supply optional) or when a power supply is malfunctioning.

- **Non-Maskable Interrupt (NMI) Button**, used at the request of Technical Support to initiate a core dump. To press this red button, which is recessed to prevent unintentional activation, use a pen, pencil, or other pointed object. The NMI Button is also available remotely over the network in the LOM GUI, in the **Remote Control** menu. For more information about the lights out management port of the appliance, see [Lights out management port of the NetScaler SDX appliance](#).

NetScaler SDX 14000

December 31, 2023

The NetScaler SDX 14020/14030/14040/14060/14080/14100 are 2U appliances. Each model has two 6-core processors and 64 GB of memory and sixteen 10G SFP+ ports (16x10G SFP+).

Note

For information about NetScaler SDX hardware and component compatibility matrix, see [NetScaler SDX Hardware-Software Compatibility Matrix](#).

The following figure shows the front panel of the SDX 14020/14030/14040/14060/14080/ 14100 (16x10G SFP+) appliance.

Figure 1. NetScaler SDX 14020/14030/14040/14060/14080/14100 (16x10G SFP+), front panel

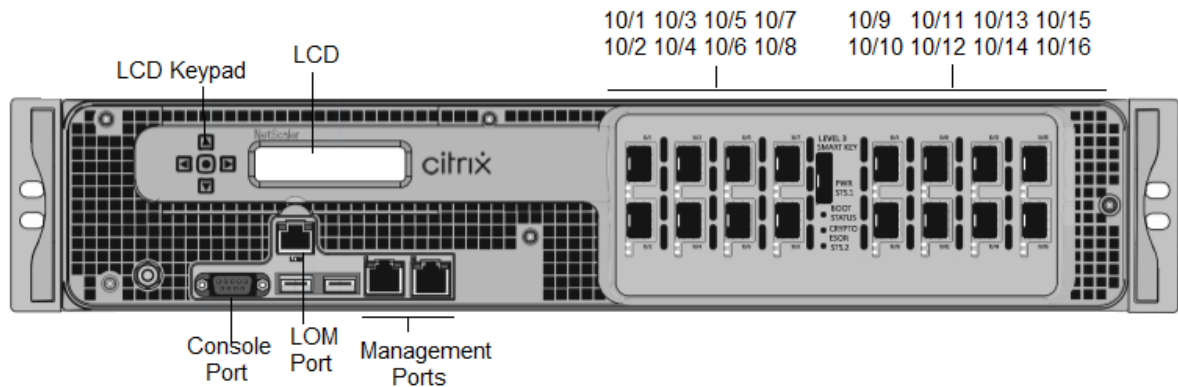

The NetScaler SDX 14020/14030/14040/14060/14080/14100 appliances have the following ports:

- RS232 serial Console Port.
- 10/100Base-T copper Ethernet Port (RJ45), also called the LOM port. You can use this port to remotely monitor and manage the appliance independently of the NetScaler software.
- Two 10/100/1000Base-T copper Ethernet management ports (RJ45), numbered 0/1 and 0/2 from left to right. These ports are used to connect directly to the appliance for system administration functions.

- Network ports, sixteen 10G SFP+ ports (16x10G SFP+).
- USB ports (reserved for a future release).

Note

The 10G SFP+ ports on these appliances support copper 1G SFP transceivers.

The following figure shows the back panel of the SDX 14020/14030/14040/14060/14080/ 14100 appliance.

Figure 2. NetScaler SDX 14020/14030/14040/14060/14080/14100, back panel

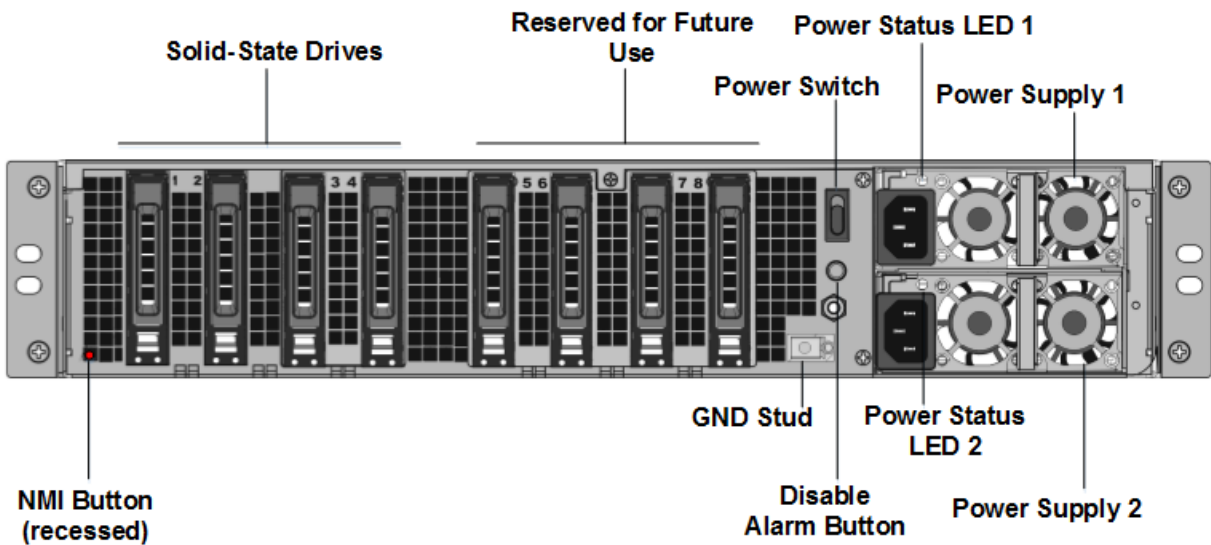

The following components are visible on the back panel of the SDX 14020/14030/14040/14060/14080/14100 appliance:

- Two 240 GB or larger removable solid-state drives in a redundant array of independent disks (RAID) configuration.

Note: These drives store the NetScaler software, and cannot be increased by users.

- Two to six 300 GB or larger solid-state drives.

Note: These drives are used to provision VPX instances. Contact NetScaler sales Support to purchase extra drives.

Note: Drive densities might increase as components become EOL but its size is never smaller than the original.

For more information about managing RAID allocation, see [Managing RAID disk allocation on SDX 22XXX](#).

- **Power switch** which turns power to the appliance on or off. Press the switch for less than two seconds to shut off the power.

- **Two power supplies.** each rated at 1000 watts, 100–240 volts. Each power supply has an LED that indicates the status of the power supply, as described in [Common hardware components](#).
- ****Disable alarm button.**** which is functional only when the appliance has two power supplies. Press this button to stop the power alarm from sounding when either of the following conditions is true:
 - You have plugged the appliance into only one power outlet
 - One power supply is malfunctioning and you want to continue operating the appliance until it is repaired.
- **Non-maskable interrupt (NMI) Button.** used at the request of Technical Support to initiate a core dump. To press this red button, which is recessed to prevent unintentional activation, use a pen, pencil, or other pointed object. The NMI Button is also available remotely over the network in the LOM GUI, in the Remote Control menu. For more information about the lights out management port of the appliance, see [Lights out management port of the NetScaler SDX appliance](#).

Note: If you buy an instance license pack for SDX 14000 that includes extra SSDs, read [CTX215581](#). Complete the steps for adding a logical drive before trying to use the additional instance licenses.

NetScaler SDX 14000-40G

December 31, 2023

The NetScaler SDX 14020-40G, SDX 14040-40G, SDX 14060-40G, SDX 14080-40G, and SDX 14100-40G are 2U appliances. Each model has two 6-core processors and 64 GB of memory. The SDX 14020-40G/14040-40G/14060-40G/14080-40G/14100-40G appliances are available in the four-40G QSFP+ ports and sixteen 10G SFP+ ports (4x40G QSFP+ + 16x10G SFP+) configuration.

For information on the software releases supported on the NetScaler hardware platforms, see [NetScaler SDX hardware-software compatibility matrix](#).

The following figure shows the front panel of the SDX 14000-40G appliance.

Figure 1. NetScaler SDX 14020-40G, SDX 14040-40G, SDX 14060-40G, SDX 14080-40G, SDX 14100-40G (4x40G QSFP+ + 16x10G SFP+), front panel

The NetScaler SDX 14000-40G appliances have the following ports:

- RS232 serial Console Port.
- 10/100Base-T copper Ethernet Port (RJ45), also called the LOM port. You can use this port to remotely monitor and manage the appliance independently of the NetScaler software.

- Two 10/100/1000Base-T copper Ethernet Management Ports (RJ45), numbered 0/1 and 0/2 from left to right. These ports are used to connect directly to the appliance for system administration functions.
- Network Ports: Four 40G QSFP+ ports and sixteen 10G SFP+ ports (4x40G QSFP+ + 16x10G SFP+). For information about supported transceivers per port, see [25G, 40G, 50G, and 100G ports](#).
- USB ports (reserved for a future release).

The following figure shows the back panel of the SDX 14000-40G appliance.

Figure 2. NetScaler SDX 14020/14040/14060/14080/14100-40G (4x40G QSFP+, 16x10G SFP+), back panel

The following components are visible on the back panel of the SDX 14000-40G appliance:

- Two 240 GB or larger removable solid-state drives (SSDs). The two leftmost solid-state drives store the NetScaler software. The next two solid-state drives store user data. The remaining four solid-state drives are reserved for future use. These appliances are a redundant array of independent disks (RAID) devices. In a RAID configuration, the same data is stored on multiple drives to improve performance, increase storage capacity, lower the risk of data loss, and provide fault tolerance.

Note: Drive densities might increase as components become EOL but its size is never smaller than the original.

- Power switch, which turns the power to the appliance on or off. Press the switch for less than two seconds to shut off the power.
- Two power supplies, each power supply is rated at 1000 watts, 100–240 volts. Each power supply has an LED that indicates the status of the power supply.
- **Disable alarm button.** This button is functional only when the appliance has two power supplies. Press this button to stop the power alarm from sounding when either of the following conditions is true:
 - You have plugged the appliance into only one power outlet.
 - One power supply is malfunctioning and you want to continue operating the appliance until it is repaired.
- Non-maskable interrupt (NMI) button that is used at the request of Technical Support to initiate a core dump. To press this red button, which is recessed to prevent unintentional activation, use a pen, pencil, or other pointed object. The NMI Button is also available remotely over the network in the LOM GUI, in the Remote Control menu. For more information about the lights out management port of the appliance, see [Lights out management port of the NetScaler SDX appliance](#).

NetScaler SDX 14xxx-40S

December 31, 2023

The NetScaler SDX 14040-40S, SDX 14060-40S, SDX 14080-40S, and SDX 14100-40S are 2U appliances. Each model has two 6-core processors and 64 GB of memory. The SDX 14040-40S/14060-40S/14080-40S/SDX 14100-40S appliances are available in the four-40S QSFP+ ports and sixteen 10G SFP+ ports (4x40G QSFP+ + 8x10G SFP+) configuration.

For information on the software releases supported on the NetScaler hardware platforms, see [NetScaler SDX hardware-software compatibility matrix](#).

The following figure shows the front panel of the SDX 14xxx-40S appliance.

Figure 1. NetScaler SDX 14040-40S, SDX 14060-40S, SDX 14080-40S, SDX 14100-40S (4x40G QSFP+ + 8x10G SFP+), front panel

The NetScaler SDX 14xxx-40S appliances have the following ports:

- RS232 serial Console Port.
- 10/100Base-T copper Ethernet Port (RJ45), also called the LOM port. You can use this port to remotely monitor and manage the appliance independently of the NetScaler software.
- Two 10/100/1000Base-T copper Ethernet Management Ports (RJ45), numbered 0/1 and 0/2 from left to right. These ports are used to connect directly to the appliance for system administration functions.
- Network Ports: Four 40S QSFP+ ports and eight 10G SFP+ ports (4x40G QSFP+ + 8x10G SFP+). For information about supported transceivers per port, see [25G, 40G, 50G, and 100G ports](#).

The following figure shows the back panel of the SDX 14xxx-40S appliance.

Figure 2. NetScaler SDX 14040/14060/14080/14100-40S (4x40G QSFP+, 8x10G SFP+), back panel

The following components are visible on the back panel of the SDX 14xxx-40S appliance:

- Two 240 GB or larger removable solid-state drives (SSDs). The two leftmost solid-state drives store the NetScaler software. The next two solid-state drives store user data. The remaining four solid-state drives are reserved for future use. These appliances are a redundant array of independent disks (RAID) devices. In a RAID configuration, the same data is stored on multiple drives to improve performance, increase storage capacity, lower the risk of data loss, and provide fault tolerance.
Note: Drive densities might increase as components become EOL but its size is never smaller than the original.
- Power switch, which turns the power to the appliance on or off. Press the switch for less than two seconds to shut off the power.

- Two power supplies, each power supply is rated at 1000 watts, 100–240 volts. Each power supply has an LED that indicates the status of the power supply.
- **Disable alarm button.** This button is functional only when the appliance has two power supplies. Press this button to stop the power alarm from sounding when either of the following conditions is true:
 - You have plugged the appliance into only one power outlet.
 - One power supply is malfunctioning and you want to continue operating the appliance until it is repaired.
- Non-maskable interrupt (NMI) button that is used at the request of Technical Support to initiate a core dump. To press this red button, which is recessed to prevent unintentional activation, use a pen, pencil, or other pointed object. The NMI Button is also available remotely over the network in the LOM GUI, in the Remote Control menu. For more information about the lights out management port of the appliance, see [Lights out management port of the NetScaler SDX appliance](#).

NetScaler SDX 14030 FIPS, 14060 FIPS, 14080 FIPS

December 31, 2023

The NetScaler models SDX 14030 FIPS, SDX 14060 FIPS, and SDX 14080 FIPS are 2U appliances. Each model has two 6-core processors, 64 GB memory, 16 10G SFP+ ports (16x10G SFP+).

Figure 1. NetScaler SDX 14030/14060/14080 FIPS front panel

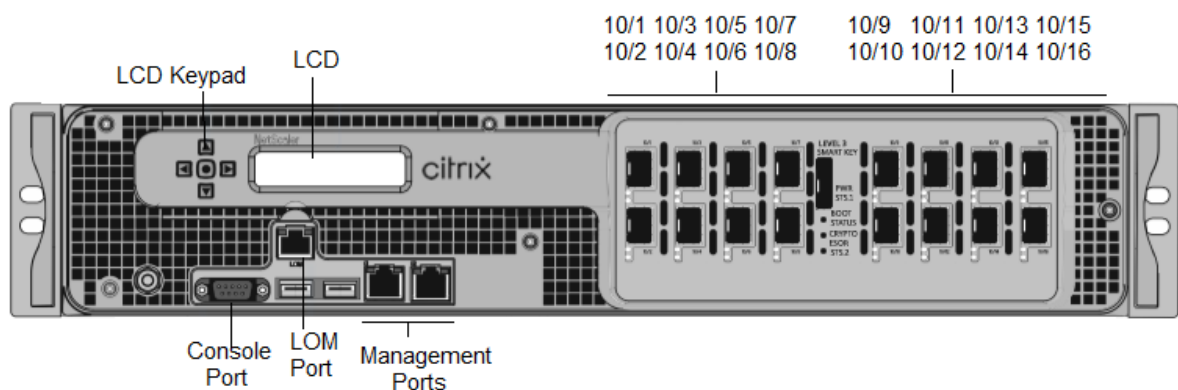

The NetScaler SDX 14030/14060/14080 FIPS appliances have the following ports:

- RS232 serial Console Port.
- 10/100Base-T copper Ethernet Port (RJ45), also called the LOM port. You can use this port to remotely monitor and manage the appliance independently of the NetScaler software.

- Two 10/100/1000Base-T copper Ethernet Management Ports (RJ45), numbered 0/1 and 0/2 from left to right. These ports are used to connect directly to the appliance for system administration functions.
- Sixteen 10G SFP+ ports.
- USB ports (reserved for a future release).

Note:

- 10G ports do not support 1G copper or 1G fiber transceivers.
- 40G ports do not support 10G and 1G transceivers.

Figure 2. NetScaler SDX 14030/14060/14080 FIPS appliance back panel

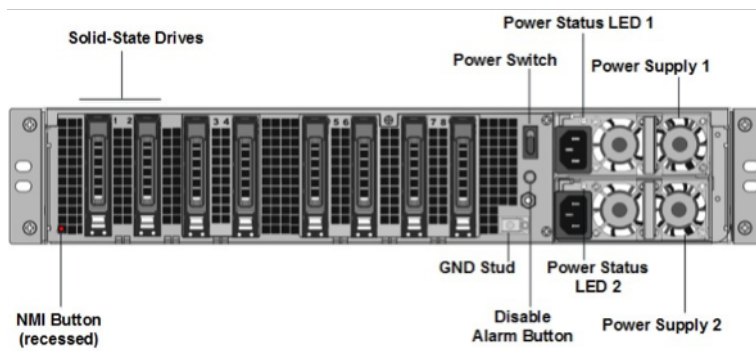

The following components are visible on the back panel of the SDX 14030 FIPS, SDX 14060 FIPS, and SDX 14080 FIPS appliances:

- Two 240 GB or larger removable solid-state drives in a redundant array of independent disks (RAID) configuration.

Note: These drives store the NetScaler software, and cannot be increased by users.

- Two to six 300 GB or larger solid-state drives.

Note: These drives are used to provision VPX instances. Contact NetScaler sales Support to purchase extra drives.

Note: Drive densities might increase as components become EOL but its size is never smaller than the original.

- **Power switch.** Which turns power to the appliance on or off. Press the switch for less than two seconds to shut off the power.
- Two power supplies, each rated at 1000 watts, 100–240 volts. Each power supply has an LED that indicates the status of the power supply, see [Common hardware components](#).
- ****Disable alarm button**.** Which is functional only when the appliance has dual redundant, hot-swappable power supplies. Press this button to silence the power alarm when one of the two power supplies loses input power or when a power supply is malfunctioning.

- **Non-maskable interrupt (NMI) button.** Used at the request of Technical Support to initiate a core dump. To press this red button, which is recessed to prevent unintentional activation, use a pen, pencil, or other pointed object. The NMI Button is also available remotely over the network in the lights out management GUI, in the Remote Controlment. For more information, see [Lights out management port of the NetScaler SDX appliance](#).

See [Configuring an SDX 14000 FIPS appliance](#) for more information about how to configure an SDX 14030/14060/14080 FIPS appliance.

NetScaler SDX 15000

December 31, 2023

The NetScaler SDX 15020/15030/15040/15060/15080/15100/15120 appliances are 2U appliances. This platform has two 8-core processors and 128 GB of memory. The appliance provides a total of 16 Ethernet 25G ports.

For information on the software releases supported on the NetScaler hardware platforms, see [NetScaler SDX hardware-software compatibility matrix](#).

The following figure shows the front panel of the SDX 15000 series appliances.

Figure 1. NetScaler SDX 15000, front panel

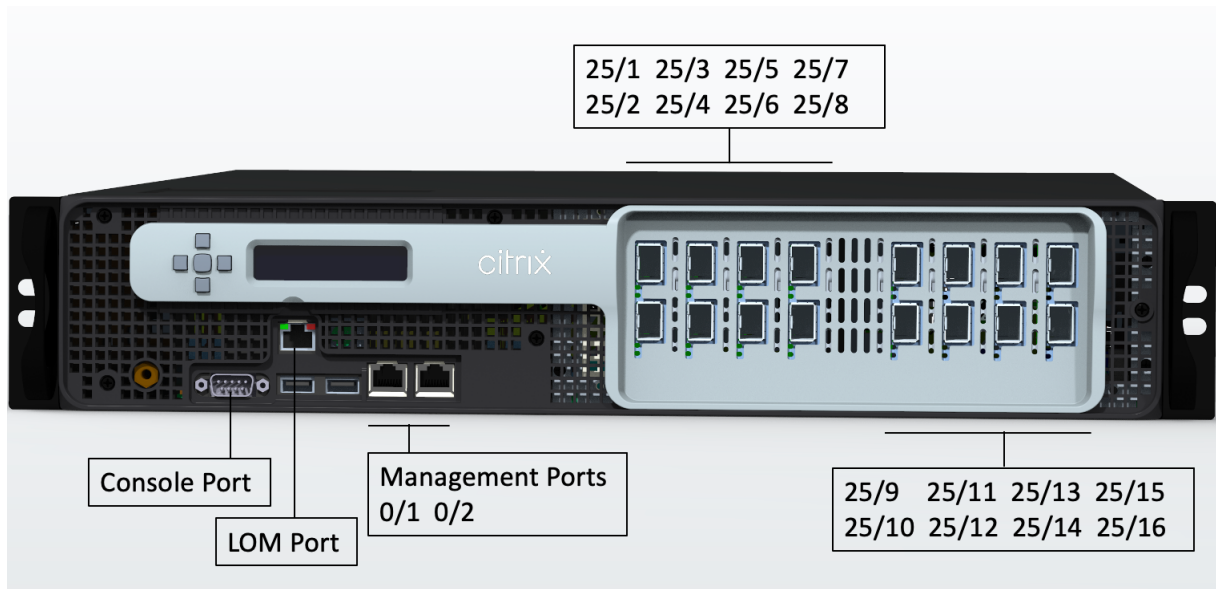

The NetScaler SDX 15000 series appliances have the following ports:

- RS232 serial console port.

- One 10/100/1000Base-T RJ45 copper Ethernet LOM Port. Use this port to remotely monitor and manage the appliance independently of the NetScaler software.
- One 10/100/1000Base-T RJ45 copper Ethernet Management Port, numbered 0/1. This port is used to connect directly to the appliance for NetScaler administration functions.
- Sixteen 25G Ethernet ports, numbered 25/1 to 25/16. For information about supported transceivers per port, see [25G, 40G, 50G, and 100G ports](#).

The following figure shows the back panel of the SDX 15000 appliance.

Figure 2. NetScaler SDX 15000, back panel

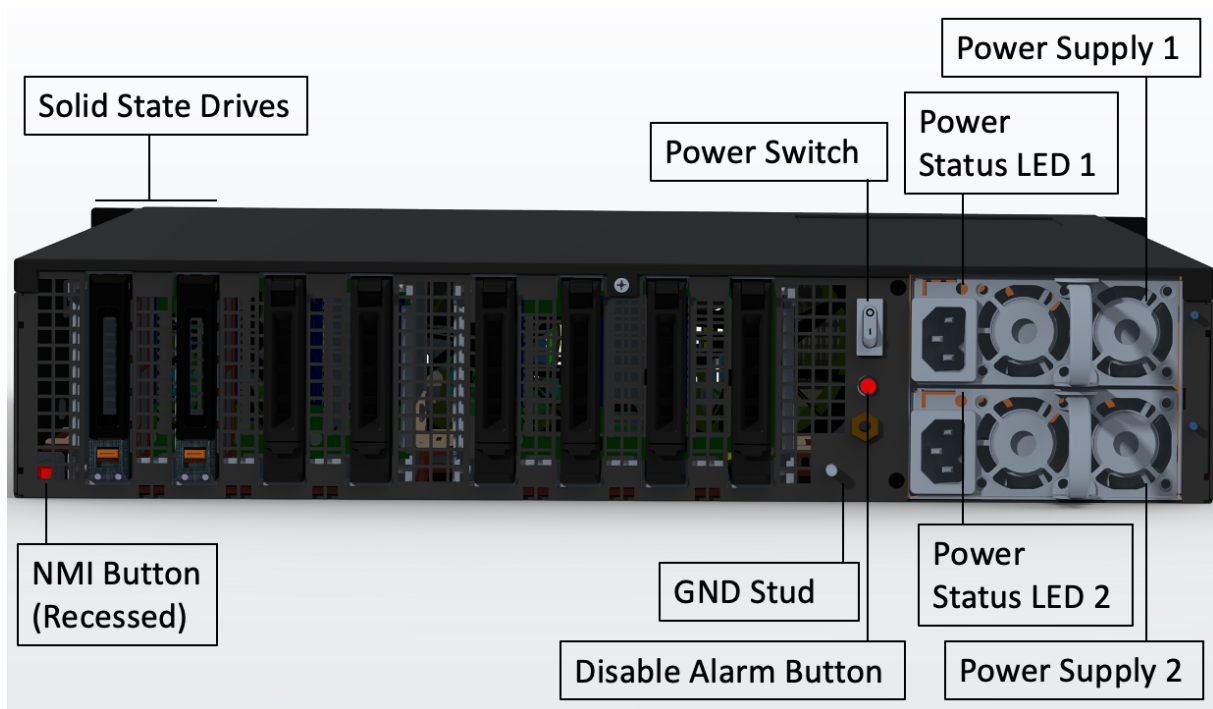

The following components are visible on the back panel of the SDX 15000 appliance:

- Four 240 GB and four 480 GB removable solid-state drives (SSD). Two 240 GB are used by the system while the remaining are used for virtual instances and in RAID 1 pairs.
Note: Drive densities might increase as components become EOL but its size is never smaller than the original.
- Power switch, which turns power to the appliance on or off.
 - If the OS is functional, press the switch for less than two seconds to shut down the system gracefully.
 - If the OS is not responsive, press the power switch for more than 4 seconds to force the power off.
- Two hot-swappable 100–240 VAC input power-supply modules. Each power supply has an LED indicating its status:

LED Color	LED Indicates
OFF	No power to any power supply in the appliance.
Flashing RED	No power to this power supply.
Flashing GREEN	Power supply is in standby mode.
GREEN	Power supply is functional.
RED	Power supply failure.
Flashing RED and GREEN	Warning (OVP/UVP/OCP/OTP/Fan); OVP = Over Voltage Protection; UVP = Under Voltage Protection; OCP = Over Current Protection; OTP = Over Temperature Protection

- **Disable alarm button:** functional only when the appliance has two power supplies. Press this button to silence the power alarm when one of two power supplies loses input power (second power supply optional) or when a power supply is malfunctioning.
- **Non-Maskable Interrupt (NMI) button:** recessed to prevent unintentional activation and used at the request of Technical Support to initiate a core dump. To press this red button, use a pen, pencil, or other pointed object. The NMI button is also available remotely over the network in the LOM GUI, in the Remote Control menu. For more information, see [Lights out management port of the NetScaler SDX appliance](#) topic.

NetScaler SDX 15000-50G

December 31, 2023

The NetScaler SDX 15020/15030/15040/15060/15080/15100/15120 50G models are 2U appliances. This platform has a dual 8-core processor and 128 GB memory. The SDX 15000-50G appliance provides a total of 12 network ports:

- Eight 10G SFP+ Ethernet Ports
- Four 50G Ethernet Ports

For information about the software releases supported on the NetScaler hardware platforms, see [NetScaler SDX Hardware and Component Compatibility Matrix](#)

The illustrations in this guide are only indicative and might not represent the actual NetScaler appliance.

Figure 1. NetScaler SDX 15000-50G, front panel

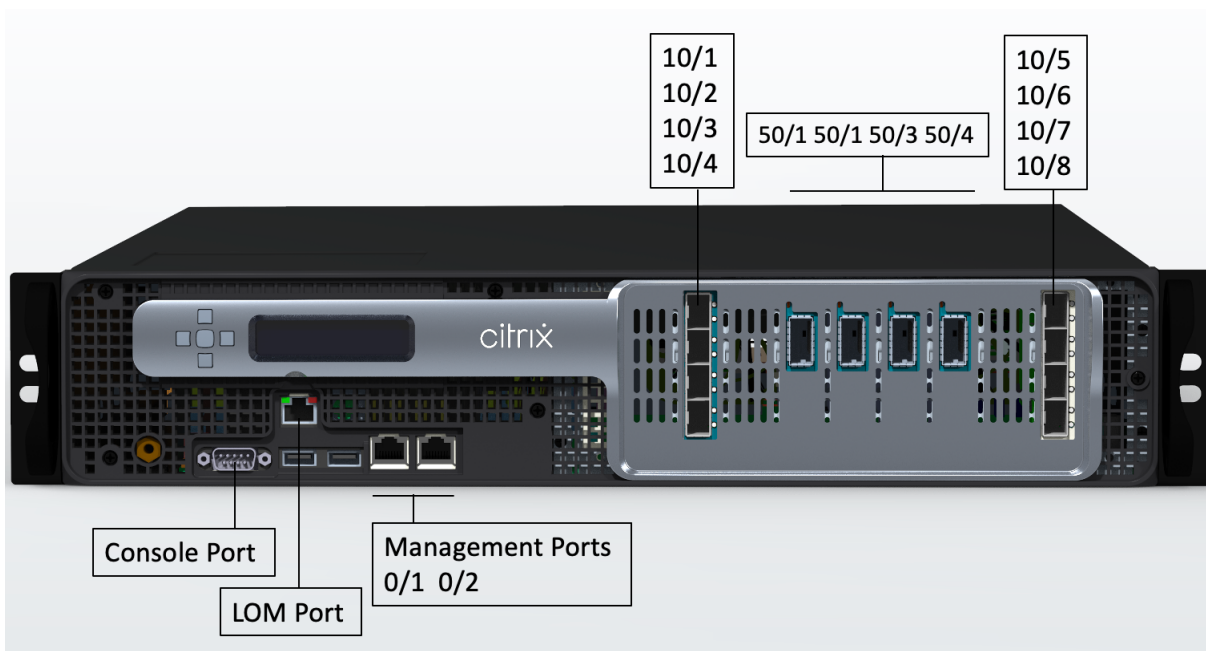

The NetScaler SDX 15000-50G appliance has the following ports:

- One RS232 Serial Console Port.
- One 10/100/1000 Base-T RJ45 copper Ethernet lights out management port. Use this port to remotely monitor and manage the appliance independently of the NetScaler software.
- Two 10/100/1000Base-T RJ45 copper Ethernet Management Ports, numbered 0/1 and 0/2. These ports are used to connect directly to the appliance for NetScaler administration functions.
- Eight 10G SFP+ Ethernet ports, numbered 10/1 to 10/8. Each port has its own LED.
- Four 50G ports, numbered 50/1 to 50/4. Each port has its own LED. For information about supported transceivers per port, see [25G](#), [40G](#), [50G](#), and [100G ports](#).

Figure 2. NetScaler SDX 15000-50G, rear panel

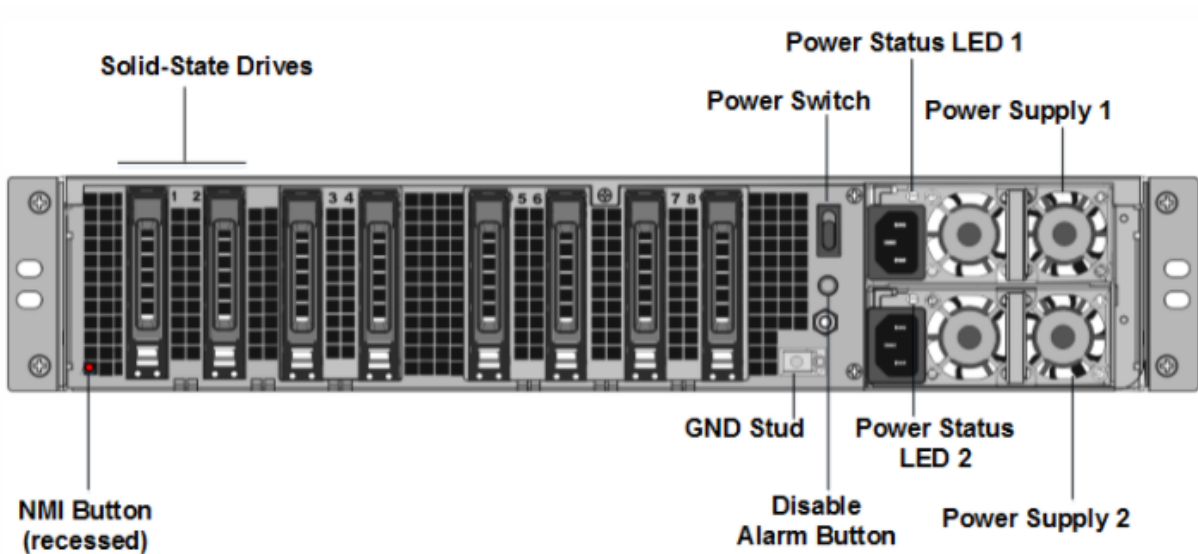

The back panel of the SDX 15000-50G appliance has the following components:

- Two 240 GB RAID-supported removable boot solid-state drives (SSDs), (slots 1 and 2) as shown in figure 2. Two 240 GB RAID-supported removable storage repositories (slots 3 and 4 paired) SSDs, and four 480 GB storage repositories (slots 5–6 paired and 7–8 paired) SSDs.

Note: Drive densities might increase as components become EOL but its size is never smaller than the original.

- A power switch, which turns power to the appliance on or off. If the OS is functional, press the switch for less than two seconds to power down the system with a graceful shutdown. If the OS is not responsive, press the power switch for more than 4 seconds to force the power off.
- Two hot-swappable 100–240 VAC input power supply modules. Each power supply has an LED indicating its status, as shown in the following table.

LED Color	LED Indicates
OFF	No power to any power supply in the appliance.
Flashing RED	No power to this power supply module.
Flashing GREEN	Power supply is in standby mode.
GREEN	Power supply is functional.
RED	Power supply failure.
Flashing RED and GREEN	Warning (OVP/UVP/OCP/OTP/Fan); OVP = Over Voltage Protection; UVP = Under Voltage Protection; OTP = Over Temperature Protection.

- A **Disable alarm button**, which is functional only when the appliance has dual redundant, hot-swappable power supplies. Press this button to silence the power alarm when one of the two power supplies loses input power or when a power supply is malfunctioning.
- A Non-Maskable Interrupt (NMI) button, used at the request of Technical Support to initiate a core dump. To press this red button, which is recessed to prevent unintentional activation, use a pen, pencil, or other pointed object. The NMI Button is also available remotely over the network in the LOM GUI, in the Remote Control menu. For more information about the lights out management port of the appliance, see [Lights out management port of the NetScaler SDX appliance](#).

NetScaler SDX 16000

December 31, 2023

The NetScaler SDX 16000 appliance is a 2U appliance. This platform has two 16-core processors and 256 GB (16 x 16 GB DIMM) of memory. The appliance provides a total of eight 25G SFP28 ports and four 100G QSFP28 Ethernet ports.

For information on the software releases supported on the ADC hardware platforms, see [Hardware-Software Release Matrix](#).

The following figure shows the front panel of the SDX 16000 appliance.

Figure 1. NetScaler SDX 16000, front panel

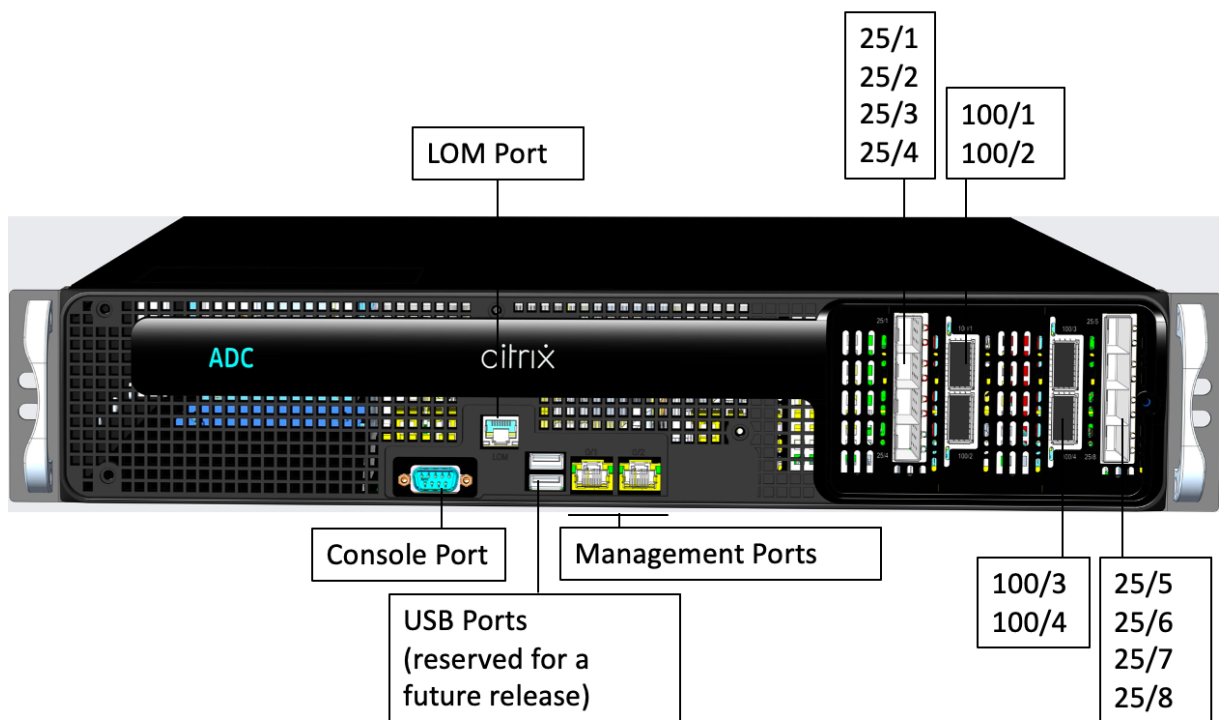

The NetScaler SDX 16000 series appliances have the following ports:

- RS232 serial Console port.
- One 10/100/1000Base-T RJ45 copper Ethernet LOM port. Use this port to remotely monitor and manage the appliance independently of the ADC software.
- Two 10/100/1000Base-T RJ45 copper Ethernet management ports, numbered 0/1 and 0/2. These ports are used to connect directly to the appliance for ADC administration functions.
- Two USB ports (reserved for a future release).
- Eight 25G SFP28 ports, numbered 25/1 to 25/8. Four 100G QSFP28 ports, numbered 100/1 to 100/4. For information about supported transceivers per port, see [25G](#), [40G](#), [50G](#), and [100G ports](#).

The following figure shows the back panel of the SDX 16000 appliance.

Figure 2. NetScaler SDX 16000, back panel

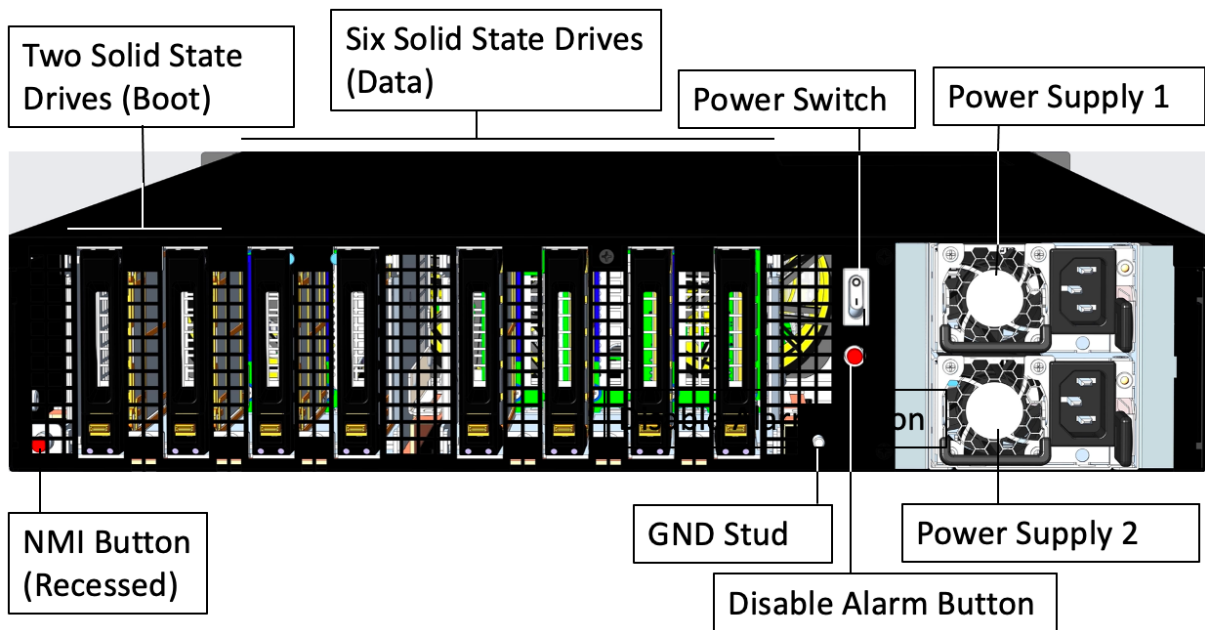

The following components are visible on the back panel of the SDX 16000 appliance:

- Two 480 GB removable solid-state drives (boot drives).
 - Six 480 GB removable solid-state drives for storing data.
- Note:** Drive densities might increase as components become EOL but its size is never smaller than the original.
- Power switch, which turns power to the appliance on or off.
 - If the OS is functional, press the switch for less than two seconds to power down the system with a graceful shutdown.
 - If the OS is not responsive, press the power switch for more than 4 seconds to force the power off.
 - Two power supplies, each rated at 850 watts, 100–240 VAC. The following table indicates the LED status of each power supply:

LED Color	LED Indicates
OFF	No power to any power supply in the appliance.
Flashing RED	No power to this power supply.
Flashing GREEN	Power supply is in standby mode.
GREEN	Power supply is functional.
RED	Power supply failure.

- **Disable alarm button**, which is functional only when the appliance has two power supplies. Press this button to silence the power alarm when one of two power supplies loses input power (second power supply optional) or when a power supply is malfunctioning.
- **Non-Maskable Interrupt (NMI) Button**, used at the request of Technical Support to initiate a core dump. To press this red button, which is recessed to prevent unintentional activation, use a pen, pencil, or other pointed object. The NMI Button is also available remotely over the network in the LOM GUI, in the **Remote Control** menu. For more information about the lights out management port of the appliance, see [Lights out management port of the NetScaler SDX appliance](#).

NetScaler SDX 25100A, SDX 25160A

December 31, 2023

The NetScaler SDX 25100A and SDX 25160A are 2U appliances. Each model has two 10-core processors, 256 GB of memory, eight 40GE QSFP+ ports (8x40GE QSFP+).

Figure 1. NetScaler SDX 25100A and SDX 25160A front panel

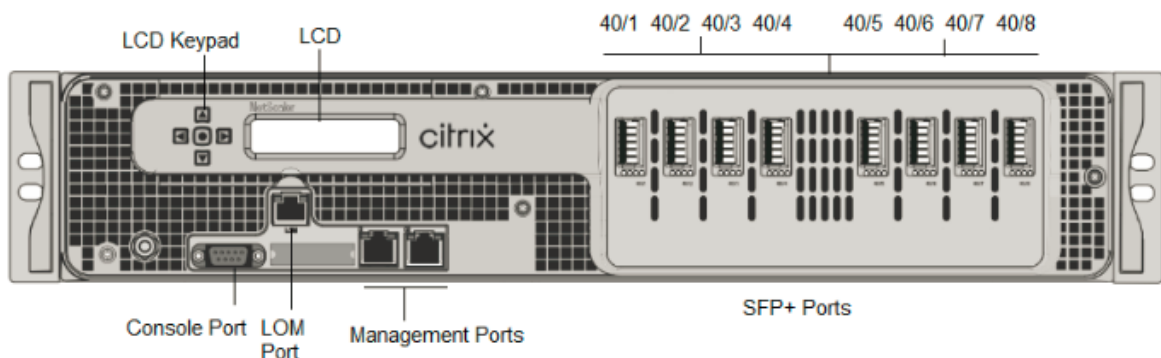

The NetScaler SDX 25160A and SDX 25100A appliances have the following ports:

- RS232 serial Console Port.
- 10/100Base-T copper Ethernet Port (RJ45), also called the LOM port. You can use this port to remotely monitor and manage the appliance independently of the NetScaler software.
- Network ports, eight 40G QSFP+ ports. For information about supported transceivers per port, see [25G, 40G, 50G, and 100G ports](#).

Note

40G ports do not support 10G and 1G transceivers.

Figure 2. NetScaler SDX 25100A and SDX 25160A back panel

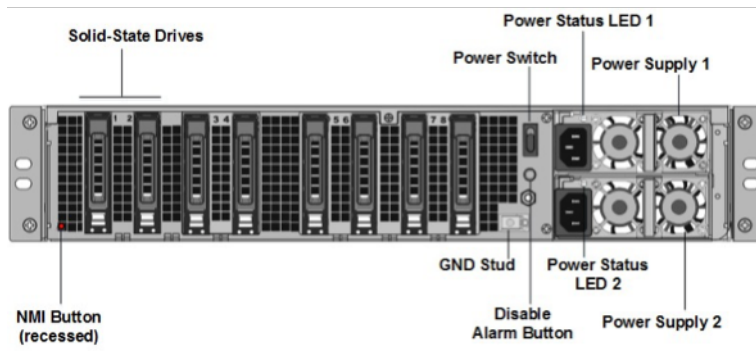

The following components are visible on the back panel of the SDX 25100A and SDX 25160A appliance:

- **Two 300 GB removable solid-state drives (SSDs).** The two leftmost solid-state drives store the NetScaler software. The next two solid-state drives store user data. The remaining four solid-state drives are reserved for future use. These appliances are a redundant array of independent disks (RAID) devices.

Note: Drive densities might increase as components become EOL but its size is never smaller than the original.

- **Power switch.** Which turns power to the appliance on or off. Press the switch for less than two seconds to shut off the power.
- **Two power supplies.** each rated at 1000 watts, 100–240 volts. Each power supply has an LED that indicates the status of the power supply.
- **Disable alarm button.** Which is functional only when the appliance has dual redundant, hot-swappable power supplies. Press this button to silence the power alarm when one of the two power supplies loses input power or when a power supply is malfunctioning.
- **Non-maskable interrupt (NMI) button.** Used at the request of Technical Support to initiate a core dump. To press this red button, which is recessed to prevent unintentional activation, use a pen, pencil, or other pointed object. The NMI Button is also available remotely over the network in the LOM GUI, in the Remote Control menu. For more information about the lights out management port of the appliance, see [Lights out management port of the NetScaler SDX appliance](#).

NetScaler SDX 25100-40G

December 31, 2023

The NetScaler SDX 25100-40G and SDX 25160-40G are 2U appliances. Each model has two 10-core processors, 256 GB of memory, four 40G QSFP+ ports, and sixteen 10G SFP+ ports (4x40G QSFP+ + 16x10G SFP+).

Figure 1. NetScaler SDX 25100 40G, SDX 25160 40G (4x40G QSFP+ + 16x10G SFP+) front panel

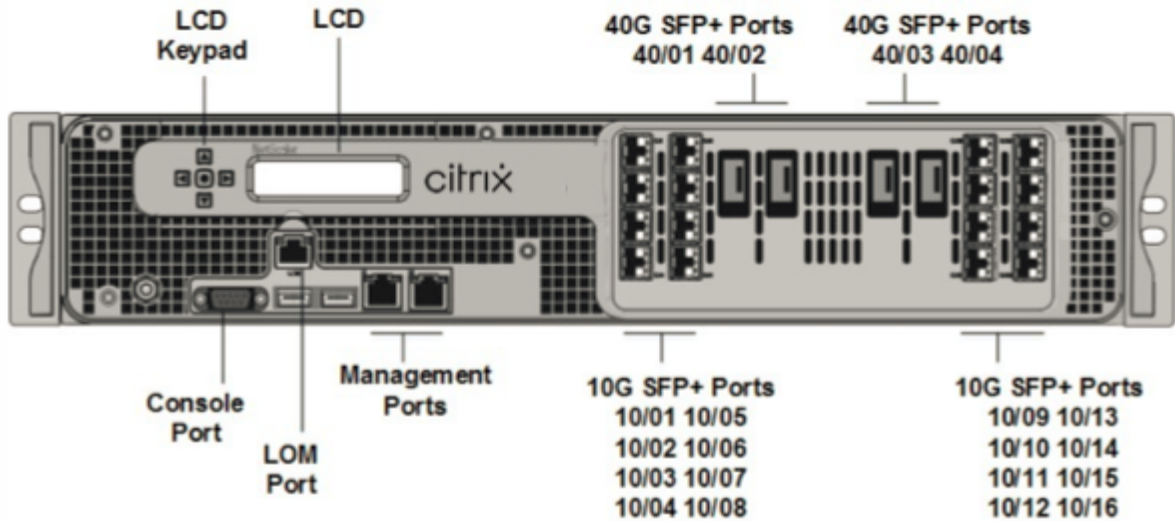

The NetScaler SDX 25100 40G, SDX 25160 40G appliances have the following ports:

- RS232 serial Console Port.
- 10/100Base-T copper Ethernet Port (RJ45), also called the LOM port. You can use this port to remotely monitor and manage the appliance independently of the NetScaler software.
- Two 10/100/1000Base-T copper Ethernet Management Ports (RJ45), numbered 0/1 and 0/2 from left to right. These ports are used to connect directly to the appliance for system administration functions.
- Network Ports: Four 40G QSFP+ ports and sixteen 10G SFP+ ports (4x40G QSFP+ + 16x10G SFP+). For information about supported transceivers per port, see [25G](#), [40G](#), [50G](#), and [100G ports](#).
- USB ports (reserved for a future release).

Note:

- 10G ports do not support 1G copper or 1G fiber transceivers.
- 40G ports do not support 10G and 1G transceivers.

Figure 2. NetScaler SDX 25100-40G and SDX 25160-40G back panel

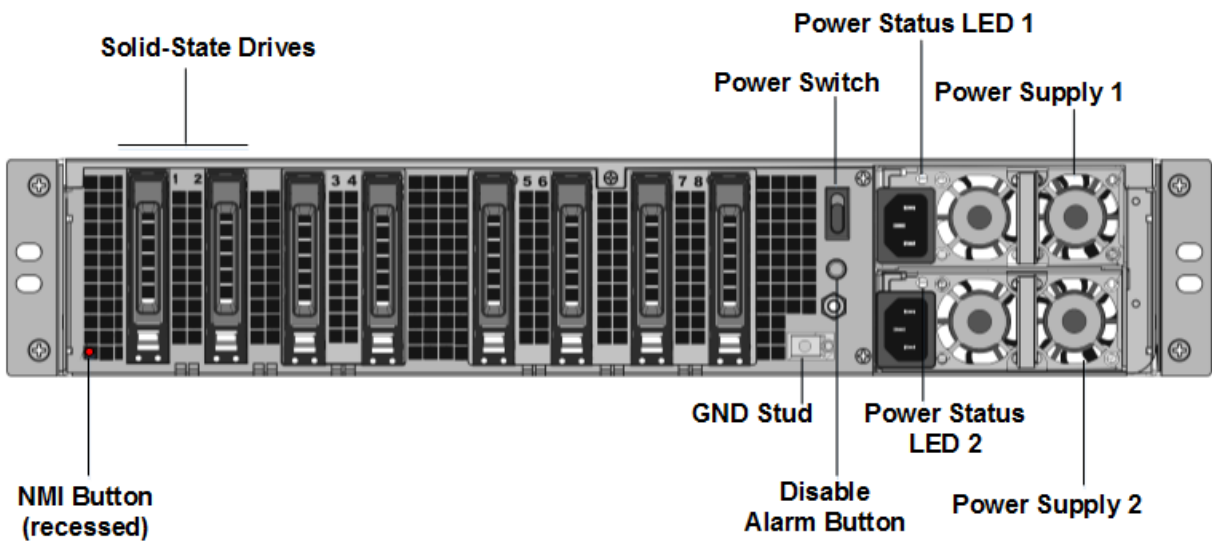

The following components are visible on the back panel of the SDX 25100-40G, SDX 25160-40G appliance:

- **Two 300 GB removable solid-state drives (SSDs).** The two leftmost solid-state drives store the NetScaler software. The next two solid-state drives, of 300 GB each, store user data. The remaining four solid-state drives are reserved for future use.
Note: Drive densities might increase as components become EOL but its size is never smaller than the original.
- **Power switch.** Which turns power to the appliance on or off? Press the switch for less than two seconds to shut off the power.
- **Two power supplies.** Each rated at 1000 watts, 100–240 volts. Each power supply has an LED that indicates the status of the power supply, as described in [Common Hardware Components](/en-us/netscaler-hardware-platforms/sdx/common-hardware-components.html).
- **Disable alarm button.** Which is functional only when the appliance has dual redundant, hot-swappable power supplies. Press this button to silence the power alarm when one of the two power supplies loses input power or when a power supply is malfunctioning.
- **Non-maskable interrupt (NMI) button.** Used at the request of Technical Support to initiate a core dump. To press this red button, which is recessed to prevent unintentional activation, use a pen, pencil, or other pointed object. The NMI Button is also available remotely over the network in the LOM GUI, in the Remote Control menu. For more information about the lights out management port of the appliance, see [Lights out management port of the NetScaler SDX appliance](#).

NetScaler SDX 26000

December 31, 2023

The NetScaler SDX 26000 appliances are 2U appliances. These appliances have two 14-core processors and 256 GB of memory. The appliance has eight 50G and sixteen 25G network ports.

For information about the software releases supported on the NetScaler hardware platforms, see [NetScaler SDX hardware-software compatibility matrix](#).

The following figure shows the front panel of the NetScaler SDX 26000 appliances.

Figure 1. NetScaler SDX 26000, front panel

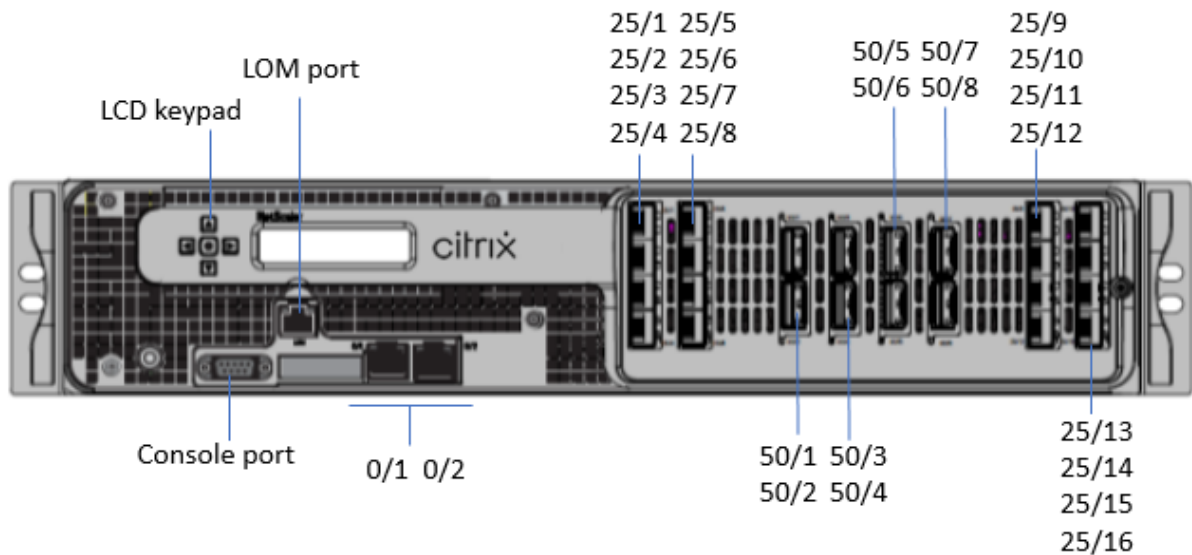

The NetScaler SDX 26000 appliances have the following ports:

- RS232 serial console port.
- One 10/100/1000Base-T RJ45 copper Ethernet LOM Port. Use this port to remotely monitor and manage the appliance independently of the NetScaler software.
- Two 10/100/1000Base-T RJ45 copper Ethernet Management Ports, numbered 0/1 and 0/2. These ports are used to connect directly to the appliance for NetScaler administration functions.
- Eight 50G ports, numbered 50/1 to 50/8.
- Sixteen 25G ports, numbered 25/1 through 25/16. For information about supported transceivers per port, see [25G, 40G, 50G, and 100G ports](#).

The following figure shows the back panel of the SDX 26000 appliances.

Figure 2. NetScaler SDX 26000, back panel

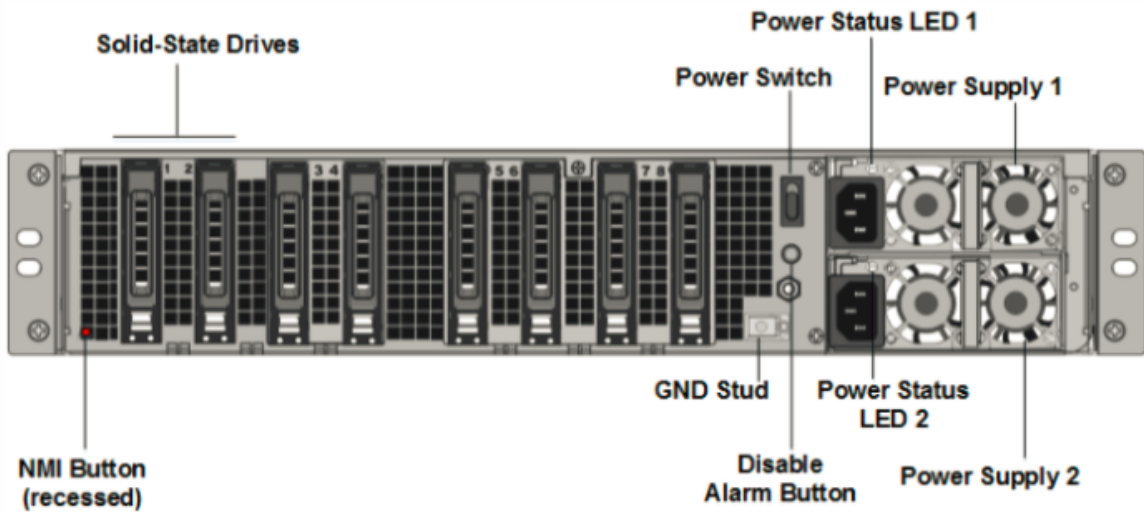

The following components are visible on the back panel of the NetScaler SDX 26000 appliances:

- Two 240 GB and six 960 GB removable solid-state drive (SSD).
 - Note:** Drive densities might increase as components become EOL but its size is never smaller than the original.
- Power switch, which turns power to the appliance on or off.
 - If the OS is functional, press the switch for less than two seconds to power down the system with a graceful shutdown.
 - If the OS is not responsive, press the power switch for more than 4 seconds to force the power off.
- Two hot-swappable 100–240 VAC, 1000 W power supply modules. Max power consumption is 672 W. Typical power consumption is 540 W. Each power supply has an LED indicating its status as follows:

LED Color	LED Indicates
OFF	No power to any power supply on the appliance.
Flashing RED	No power to this power supply.
Flashing GREEN	Power supply is in standby mode.
GREEN	Power supply is functional.
RED	Power supply failure.

LED Color	LED Indicates
Flashing RED and GREEN	Warning (OVP/UVP/OCP/OTP/Fan); OVP = Over Voltage Protection; UVP = Under Voltage Protection; OCP = Over Current Protection; OTP = Over Temperature Protection

- **Disable alarm button.** Press this button to silence the power alarm when one of two power supplies loses input power or when a power supply is malfunctioning.
- Non-Maskable Interrupt (NMI) Button, used at the request of Technical Support to initiate a core dump. To press this red button, which is recessed to prevent unintentional activation, use a pen, pencil, or other pointed object. The NMI Button is also available remotely over the network in the LOM GUI, in the Remote Control menu. For more information, see [Lights out management port of the NetScaler SDX appliance.](#)

NetScaler SDX 26000-50S

December 31, 2023

The NetScaler SDX 26xxx-50S appliances are 2U appliances. These appliances have two 14-core processors and 256 GB of memory. The appliances have four 50G and sixteen 25G network ports.

For information about software releases supported on the NetScaler hardware platforms, see [NetScaler SDX hardware-software compatibility matrix.](#)

The following figure shows the front panel of the NetScaler SDX 26xxx-50S appliances.

Figure 1. NetScaler SDX 26xxx-50S, front panel

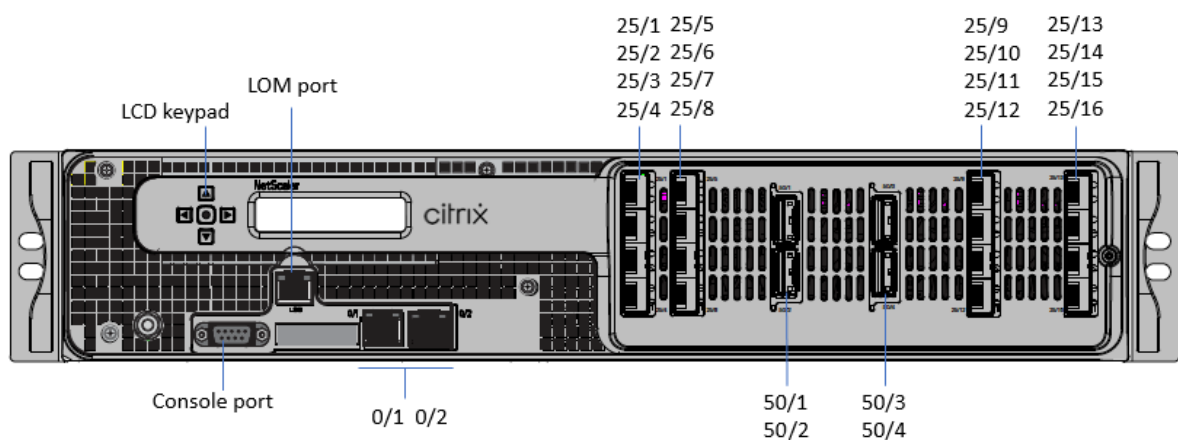

The NetScaler SDX 26xxx-50S appliances have the following ports:

- RS232 serial console port.
- One 10/100/1000Base-T RJ45 copper Ethernet LOM Port. Use this port to remotely monitor and manage the appliance independently of the NetScaler software.
- Two 10/100/1000Base-T RJ45 copper Ethernet Management Ports, numbered 0/1 and 0/2. These ports are used to connect directly to the appliance for NetScaler administration functions.
- Four 50G ports, numbered 50/1 to 50/4.
- Sixteen 25G ports, numbered 25/1 through 25/16. For information about supported transceivers per port, see [25G, 40G, 50G, and 100G ports](#).

The following figure shows the back panel of the SDX 26xxx-50S appliances.

Figure 2. NetScaler SDX 26xxx-50S, back panel

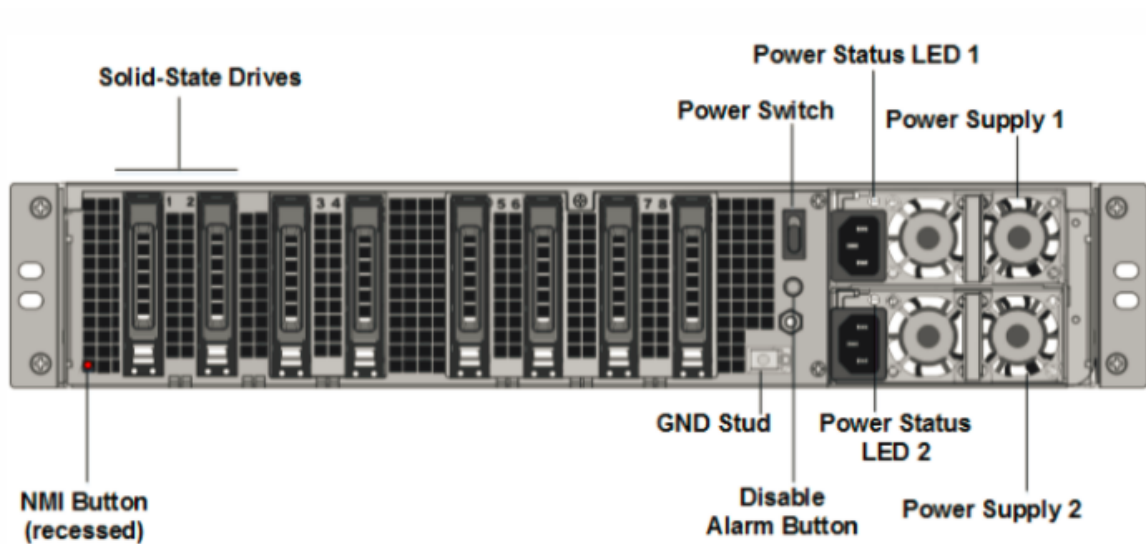

The following components are visible on the back panel of the NetScaler SDX 26xxx-50S appliances:

- Two 240GB and six 960GB removable solid-state drive (SSD).
 - Note:** Drive densities might increase as components become EOL but its size is never smaller than the original.
- Power switch, which turns power to the appliance on or off.
 - If the OS is functional, press the switch for less than two seconds to shut down gracefully.
 - If the OS is not responsive, press the power switch for more than 4 seconds, for a hard shutdown.
- Two hot-swappable 100–240 VAC, 1200 W power supply modules. Max power consumption is 764 W. Typical power consumption is 628 W. Each power supply has an LED indicating its status:

LED Color	LED Indicates
OFF	No power to any power supply on the appliance.
Flashing RED	No power to this power supply.
Flashing GREEN	Power supply is in standby mode.
GREEN	Power supply is functional.
RED	Power supply failure.
Flashing RED and GREEN	Warning;(OVP/UVP/OCP/OTP/Fan); OVP = Over Voltage Protection; UVP = Under Voltage Protection; OCP = Over Current Protection; OTP = Over Temperature Protection

- **Disable alarm button.** Press this button to silence the power alarm when the power supply loses input power or when a power supply is malfunctioning.
- Non-Maskable Interrupt (NMI) button: is recessed to prevent unintentional activation and used at the request of Technical Support to start a core dump. To press this red button, use a pen, pencil, or other pointed object. The NMI Button is also available remotely over the network in the LOM GUI, in the Remote Control menu. For more information, see [Lights out management port of the NetScaler SDX appliance](#).

NetScaler SDX 26000-100G

December 31, 2023

The NetScaler SDX 26000-100G appliance is a 2U appliance. This platform has two 14-core processors and 256 GB memory. The appliance provides a total of 8 network ports.

For information about the software releases supported on the NetScaler hardware platforms, see [NetScaler SDX Hardware-Software Compatibility Matrix\]\(/en-us/netscaler-hardware-platforms/sdx/sdx-hardware-software-compatibility-matrix.html\)](#).

The illustrations in this guide are only indicative and might not represent the actual NetScaler appliance.

Figure 1. NetScaler SDX 26000-100G front panel

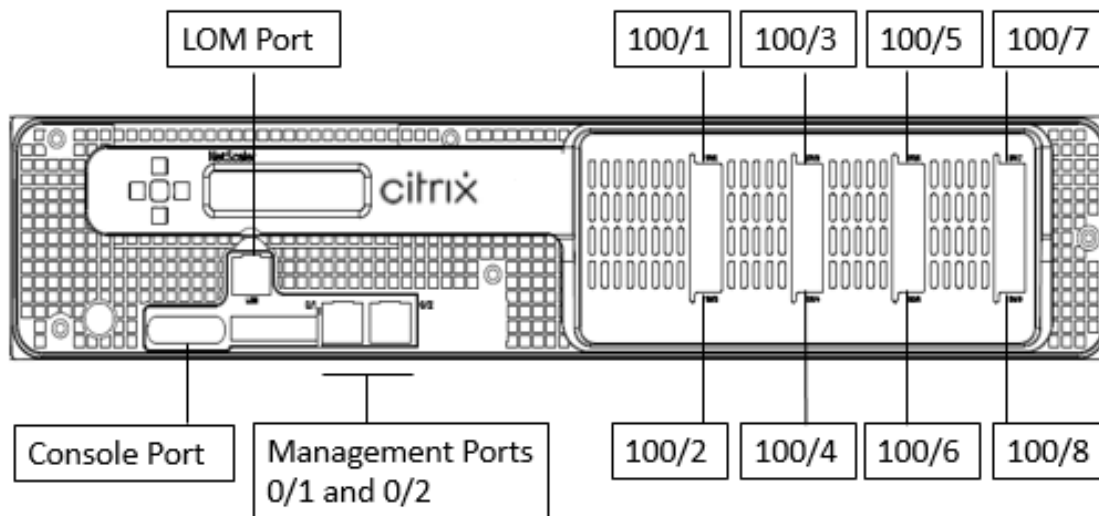

The NetScaler SDX 26000-100G appliances have the following ports:

- RS232 serial Console Port.
- One 10/100/1000Base-T RJ45 copper Ethernet LOM Port. Use this port to remotely monitor and manage the appliance independently of the NetScaler software.
- Two 10/100/1000Base-T RJ45 copper Ethernet Management Ports, numbered 0/1 and 0/2. These ports are used to connect directly to the appliance for NetScaler administration functions.
- Eight 100G Ethernet Ports, numbered 100/1 to 100/8 from left to right. For information about supported transceivers per port, see [25G](#), [40G](#), [50G](#), and [100G ports](#).

Figure 2. NetScaler SDX 26000-100G back panel

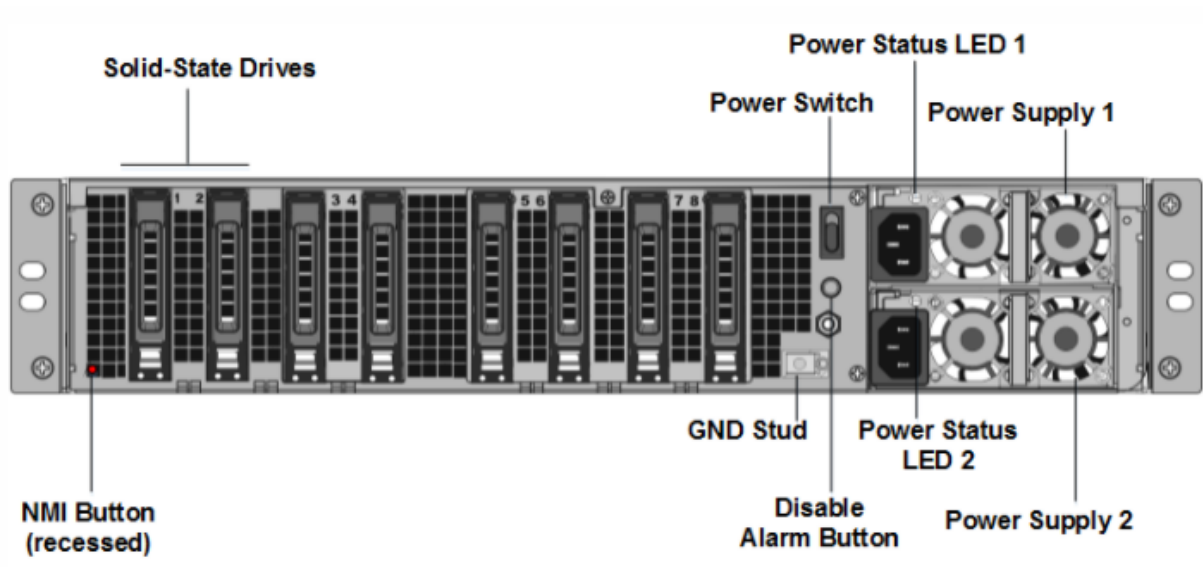

The following components are visible on the back panel of the SDX 26000-100G appliances:

- Two 240 GB removable boot solid-state drives (SSDs).
- Six 960 GB removable SSDs.
- **Note:** Drive densities might increase as components become EOL but its size is never smaller than the original.
- Power switch, which turns power to the appliance on or off.
 - If the OS is functional, press the switch for less than two seconds to power down the system with a graceful shutdown.
 - If the OS is not responsive, press the power switch for more than 4 seconds to force the power off.
- Two power supplies, 100–240 VAC. Each power supply has an LED indicating its status, as described in the following table:

LED Color	LED Indicates
OFF	No power to any power supply on the appliance.
Flashing RED	No power to this power supply.
Flashing GREEN	Power supply is in standby mode.
GREEN	Power supply is functional.
RED	Power supply failure.

LED Color	LED Indicates
Flashing RED and GREEN	Warning (OVP/UVP/OCP/OTP/Fan); OVP = Over Voltage Protection; UVP = Under Voltage Protection; OCP = Over Current Protection; OTP = Over Temperature Protection.

- **Disable alarm button**, which is functional only when the appliance has dual redundant, hot-swappable power supplies. Press this button to silence the power alarm when one of the two power supplies loses input power or when a power supply is malfunctioning.
- **Non-Maskable Interrupt (NMI) Button**, used at the request of Technical Support to initiate a core dump. To press this red button, which is recessed to prevent unintentional activation, use a pen, pencil, or other pointed object. The NMI Button is also available remotely over the network in the LOM GUI, in the Remote Control menu. For more information about the lights out management port of the appliance, see [Lights out management port of the NetScaler SDX appliance](#).

Common hardware components

July 24, 2024

Each platform has front panel and back panel hardware components. The front panel has an LCD display and an RS232 serial console port. The number, type, and location of ports—copper Ethernet, copper and fiber 1G SFP, 10GSFP+, and 40G QSFP+. The back panel provides access to the fan and the field-replaceable units (power supplies, CompactFlash cards, and solid-state and hard-disk drives).

LCD display and LED status indicators

On some NetScaler SDX appliances, the LCD on the front panel displays the appliance’s model number, but the number shown might not be the licensed model number. To view the licensed model number of any SDX appliance, log on to the Management Service and check the licensed model number in the top left corner of the screen. For example, if you have purchased an SDX 11515 license, the LCD screen displays CITRIX NSSDX-11500, and the Management Service screen displays NetScaler SDX (11515).

The LCD backlight on the NetScaler appliance is always on.

On the appliance’s back panel, system status LEDs indicate the overall status of the appliance. The following table describes the indicators of the system status LED.

On the appliance’s back panel, power status LEDs indicate the status of each power supply.

Note

System status LEDs are available on only some NetScaler SDX appliances.

LED Color	LED Indicates
OFF	No power
Green	Appliance is receiving power
Red	Appliance has detected an error

The port LEDs show whether a link is established and traffic is flowing through the port. The following table describes the LED indicators for each port. There are two LED indicators for each port type.

Note

This section applies to all the appliances.

LED port-status indicators

Port type	LED color	LED indicates
50 Gbps	Off	A link has not been established
	Blinking amber	Indicates a problem with the link
	Solid green	Indicates a valid link with no active traffic
	Blinking green	Indicates a valid link with active traffic

Port type	LED	LED	LED color	LED indicates
10 Gbps	Top	Speed	Off	No connection.
			Solid blue	Traffic rate of 10 gigabits per second
	Bottom	Link/Activity	Off	No link

Port type	LED	LED	LED color	LED indicates
1G SFP (1 Gbps)	Left	Link/Activity	Solid green	A link is established but no traffic is passing through the port
			Blinking green	Traffic is passing through the port
			Off	No link
			Solid green	A link is established but no traffic is passing through the port
Management (RJ45)	Right	Speed	Blinking green	Traffic is passing through the port
			Off	No connection
			Yellow	Traffic rate of 1 gigabit per second
			Off	No connection, or a traffic rate of 10 megabits per second (Mbps)
Management (RJ45)	Left	Speed	Green	Traffic rate of 100 Mbps
			Amber	Traffic rate of 1 gigabit per second
			Off	No link
			Solid yellow	A link is established but no traffic is passing through the port
Management (RJ45)	Right	Link/Activity	Off	No link
			Solid yellow	A link is established but no traffic is passing through the port

On each power supply, a bicolor LED indicator shows the condition of the power supply.

LED power supply indicators

Power supply type	LED color	LED indicates
AC	OFF	No power to any power supply
	Flashing RED	No power to this power supply
	Flashing GREEN	The power supply is in standby mode
	GREEN	The power supply is functional
	RED	Power supply failure

Ports

Ports are used to connect the appliance to external devices.

NetScaler appliances support RS232 serial ports, 10/100/1000Base-T copper Ethernet ports, 1-gigabit copper and fiber 1G SFP ports, 10-gigabit fiber SFP+, 25 GB, 40 GB QSFP+, 50 GB, and 100 GB ports. All NetScaler appliances have a combination of some or all of these ports. For details on the type and number of ports available on your appliance, see the section describing that platform.

Note

NetScaler appliances leverage the Receive Side Scaling (RSS) feature to optimally distribute and process traffic. The RSS implementation is based on Toeplitz hashing which distributes the packet among its queues based on the 5-tuple: TCP/IP protocol, source IP address, destination IP address, source port, and destination port.

RS232 serial port

The RS232 serial console port provides a connection between the appliance and a computer, allowing direct access to the appliance for initial configuration or troubleshooting.

All hardware platforms ship with an appropriate serial cable used to connect your computer to the appliance. For instructions on connecting your computer to the appliance, see [Installing the Hardware](#).

Copper Ethernet ports

The copper Ethernet ports installed on many models of the appliance are standard RJ45 ports.

There are two types of copper Ethernet ports that are installed on your appliance:

- 10/100BASE-T port

The 10/100BASE-T port has a maximum transmission speed of 100 megabits per second (Mbps). Most platforms have at least one 10/100BASE-T port.

- 10/100/1000BASE-T port

The 10/100/1000BASE-T port has a maximum transmission speed of 1 gigabit per second, 10 times faster than the other type of copper Ethernet port.

Most platforms have at least one 10/100/1000Base-T port.

To connect any of these ports to your network, you plug one end of a standard Ethernet cable into the port and plug the other end into the appropriate network connector.

Management ports

Management ports are standard copper Ethernet ports (RJ45), which are used for direct access to the appliance for system administration functions.

1G SFP, 10G SFP+, and 40G QSFP+ ports

A 1G SFP port can operate at a speed of 1 Gbps. It accepts either a copper 1G SFP transceiver for operation as a copper Ethernet port, or a fiber 1G SFP transceiver for operation as a fiber optic port.

The 10G SFP+ and Base-T 10G, 40G QSFP+ are high-speed ports that can operate at speeds of up to 40 Gbps. You need a fiber optic cable to connect to a port. If the other end of the fiber optic cable is attached to a 1G SFP port, the 10G SFP+ port negotiates to match the speed of the 1G SFP port.

Ports compatibility

On some appliances, the 10G slot supports **copper** 1G transceivers, which can operate at up to 1 Gbps in a 10 Gbps slot.

Note

- Certain platforms have 10G slots that do not support copper transceivers. Check with your account representative for support details.
- You cannot insert a fiber 1G transceiver into a 10G slot.
- You cannot insert a 10G transceiver into a 1G slot.

The 10G SFP+ modules are dual-speed capable and support both 1 Gbps and 10 Gbps, depending on the peer switch that the model connects to.

25G, 40G, 50G, and 100G ports

A 100G port can support five speeds: 10G, 25G, 40G, 50G, and 100G. 1G speed is not supported on the 100G port. 50G and 100G ports use the same transceiver. 40G QSFP+ are high-speed ports that can operate at speeds of up to 40 Gbps. The appliance determines the speed, and not the port.

Only 50G/100G (QSFP28) transceivers can be directly used on a QSFP28 interface. Use a QSA28 adapter on a QSFP28 interface to use 10G (SFP+) and 25G (SFP28) transceivers. Use a 40G QSFP+ transceiver in the 50G/100G port if the peer is 40G.

The following diagram shows the transceiver compatibility.

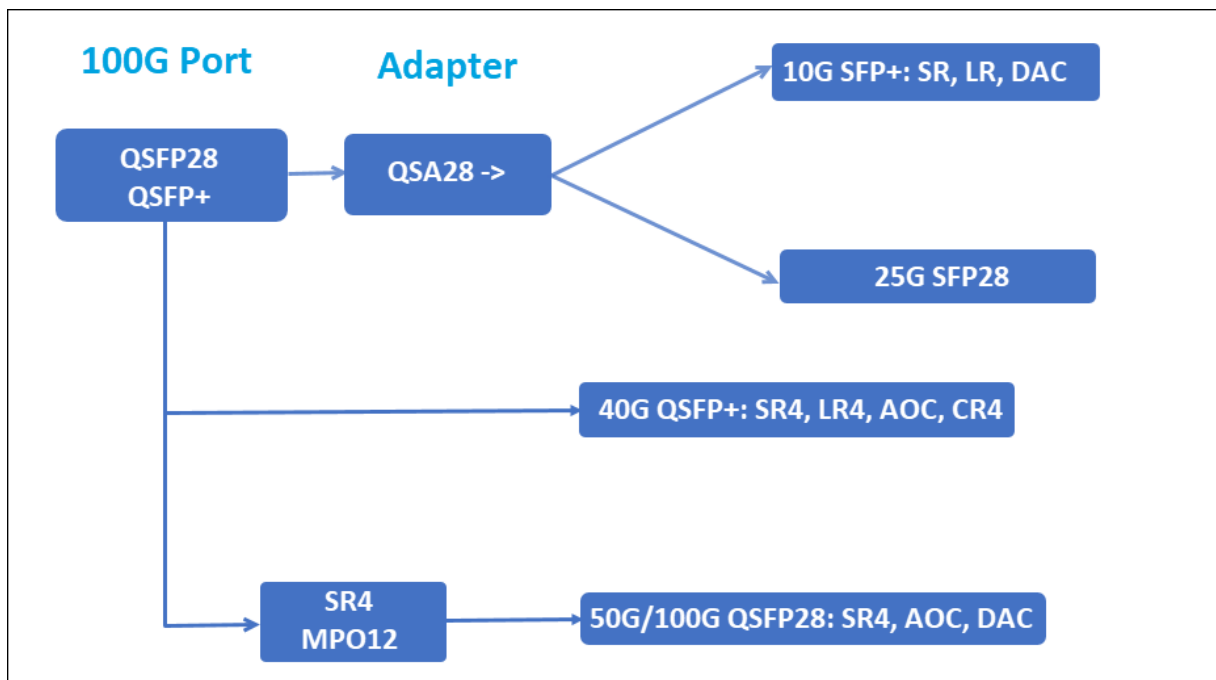

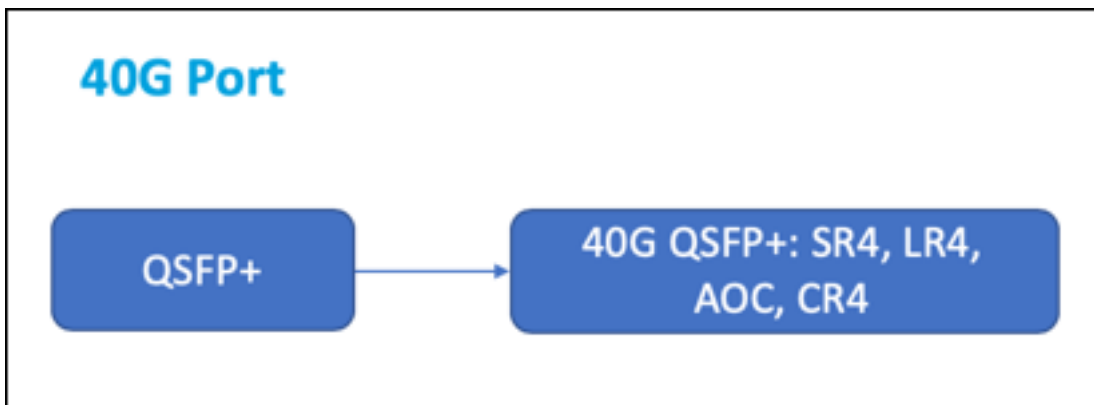
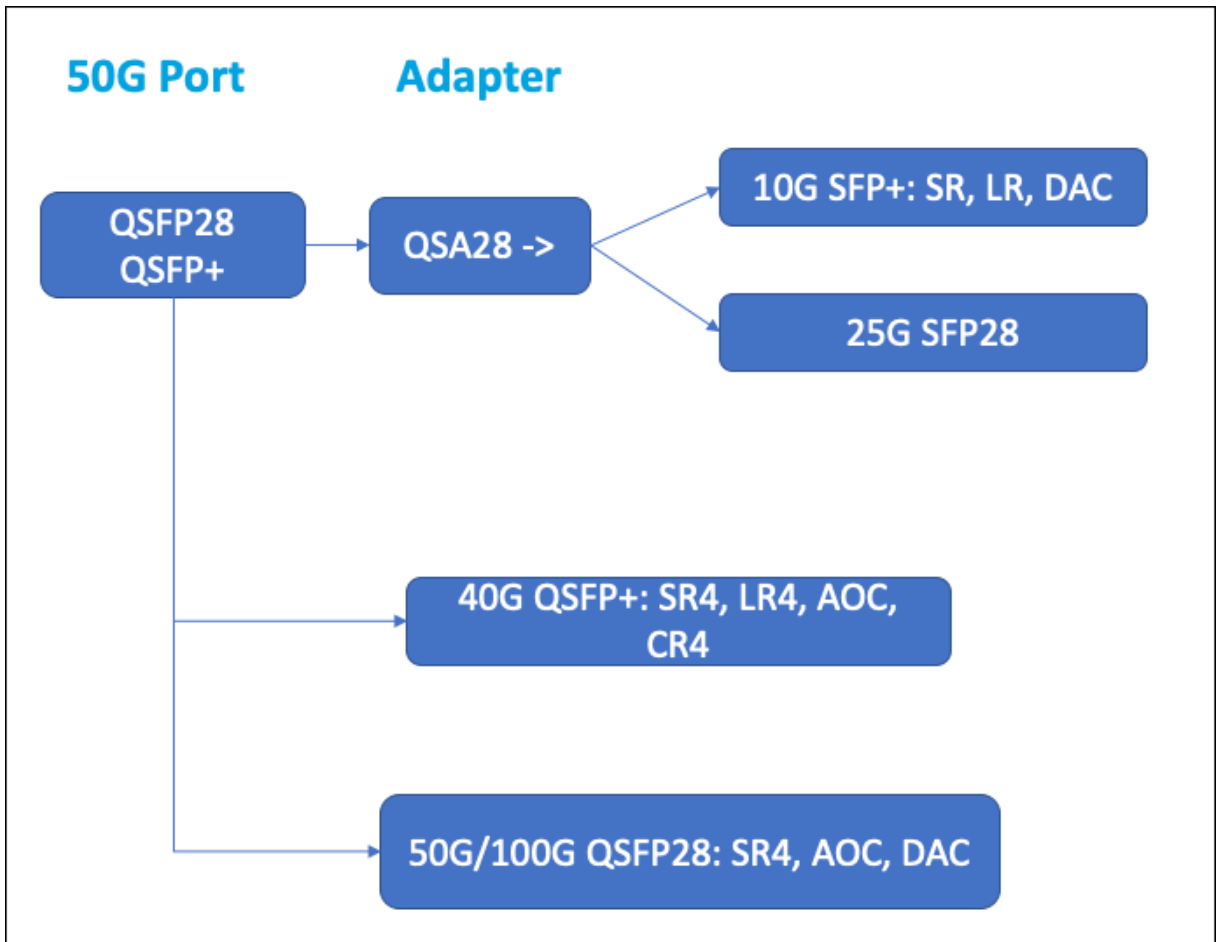

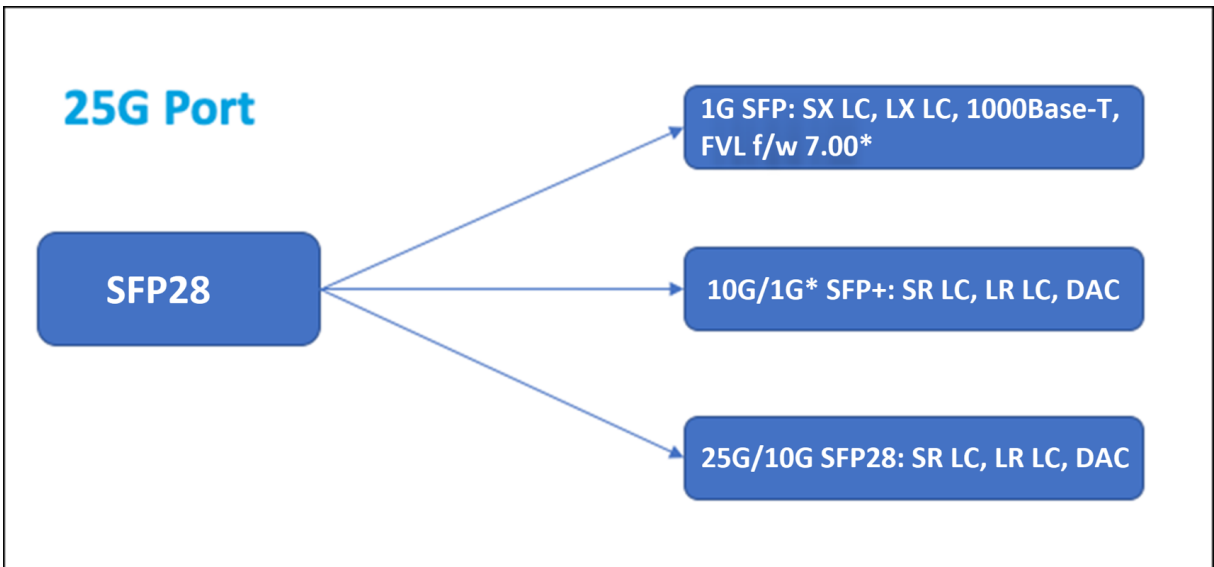

Notes:

- Fortville firmware 8.70 does not support 1G connectivity. Dual speed 10G/1G SFP+ (both SR LC and LR LC) don't operate at 1G, if Fortville firmware 8.70 is used.
- Use `i40e_firmware_view.sh` to check the FW version.
- Ensure that the FW is at version 7.0. To downgrade the firmware version to 7.0, type:

```

1 [root@netscaler-sdx ~]# echo "version 7.00" > /opt/xensource/
  packages/files/sdx-firmware/i40efirmware-target
2 [root@netscaler-sdx ~]# echo "version 7.00" > /opt/xensource/
  packages/files/sdx-firmware/i40efirmware-direction
3 [root@netscaler-sdx ~]#reboot
  
```

Most tables have the following columns:

- **Description:** The price list description of the part.
- **Transmit Wavelength:** The nominal transmit wavelength.
- **Cable/Fiber Type:** Fiber characteristics affect the maximum transmit distance achievable, especially with 10G on multi-mode fiber (MMF), where various dispersion components become dominant. For more information, see <http://www.thefoa.org/tech/ref/basic/fiber.html>.
- **Typical Reach:** Maximum transmit distance.
- **Products:** Some chassis are available with different media options. Use the appropriate data sheet to confirm that your particular chassis type supports the media.

1G pluggable media

The following table lists the maximum distance specifications for 1G transceivers.

Copper 1G SFP distance specifications Description: NetScaler 1G SFP Ethernet copper (100 m) - 4 pack

Transmitter wavelength (nm): Not applicable

Cable type: Category 5 (Cat-5) copper cable

Typical reach (m): 100 m

Applicable platforms:

- SDX 14000
- SDX 16000
- SDX 22040/22060/22080/22100/22120
- SDX 24100/24150

Short reach fiber 1G SFP distance specifications Description: NetScaler 1G SFP Ethernet SX (300 m) - 4 pack

Transmitter wavelength (nm): 850 nm (nominal)

Fiber type: 50/125um MMF, 2000MHz-km (OM3) Typical Reach (m): 550 m

Fiber type: 50/125um MMF, 500MHz-km (OM2) Typical Reach (m): 550 m

Fiber type: 50/125um MMF, 400MHz-km Typical Reach (m): 550 m

Fiber type: 62.5/125um MMF, 200MHz-km (OM1) Typical Reach (m): 300 m

Fiber type: 62.5/125um MMF, 160MHz-km Typical Reach (m): 300 m

Applicable platforms:

SDX 22040/22060/22080/22100/22120

SDX 24100/24150

Short reach fiber 1G SFP distance specifications Description: NetScaler 1G SFP Ethernet short range (300 m) - Single

Transmitter wavelength (nm): 850 nm (nominal)

Fiber type: 50/125um MMF, 2000MHz-km (OM3) Typical Reach (m): 550 m

Fiber type: 50/125um MMF, 500MHz-km (OM2) Typical Reach (m): 550 m

Fiber type: 50/125um MMF, 400MHz-km Typical Reach (m): 550 m

Fiber type: 62.5/125um MMF, 200MHz-km (OM1) Typical Reach (m): 275 m

Fiber type: 62.5/125um MMF, 160MHz-km Typical Reach (m): 220 m

Applicable platforms:

- SDX 22040/22060/22080/22100/22120
- SDX 24100/24150

Long reach fiber 1G SFP distance specifications Description: NetScaler 1G SFP Ethernet LX - Single

Transmitter wavelength (nm): 1310 nm (nominal)

Fiber type: 9/125um SMF

Typical reach (m): 10 km

Applicable platforms:

- SDX 22040/22060/22080/22100/22120
- SDX 24100/24150

Long reach fiber 1G SFP distance specifications Description: NetScaler 1G SFP Ethernet long range (10 km) - Single

Transmitter wavelength (nm): 1310 nm (nominal)

Fiber type: 9/125um SMF

Typical reach (m): 10 km

Applicable platforms:

- SDX 22040/22060/22080/22100/22120
- SDX 24100/24150

10 GE pluggable media

The following table lists the maximum distance specifications for 10G transceivers.

Short reach fiber 10G SFP+ distance specifications Description: NetScaler 10G SFP+, Ethernet Short Range (300 m) - Single

Transmitter wavelength (nm): 850 nm (nominal)

Fiber types

50/125um MMF, 2000MHz-km (OM3), typical reach (m): 300 m

50/125um MMF, 500MHz-km (OM2), typical reach (m): 82 m

50/125um MMF, 400MHz-km, typical reach 66 m

62.5/125um MMF, 200MHz-km (OM1), typical reach: 33 m

62.5/125um MMF, 160MHz-km, typical reach: 26 m

Applicable platforms:

- SDX 9100
- SDX 14000
- SDX 14000-40G
- SDX 14000-40S
- SDX 14000 FIPS
- SDX 15000
- SDX 15000-50G (adapter required to connect 50G ports to 10G transceiver)
- SDX 16000 (adapter required to connect 100G ports to 10G transceiver)
- SDX 22040/22060/22080/22100/22120
- SDX 24100/24150
- SDX 25000-40G
- SDX 26000 (adapter required to connect 50G ports to 10G transceiver)
- SDX 26000-50S (adapter required to connect 50G ports to 10G transceiver)
- SDX 26000-100G (adapter required to connect 100G ports to 10G transceiver)

Long reach fiber 10G SFP+ distance specifications Description: NetScaler 10G SFP+ Ethernet long range (10 km) - Single

Transmitter wavelength (nm): 1310 nm (nominal)

Fiber type: 9/125um SMF

Typical reach (m): 10 km

Applicable platforms:

- SDX 9100
- SDX 14000
- SDX 14000-40G
- SDX 14000-40S
- SDX 14000 FIPS
- SDX 15000
- SDX 15000-50G (adapter required to connect 50G ports to 10G transceiver)
- SDX 16000 (adapter required to connect 100G ports to 10G transceiver)
- SDX 22040/22060/22080/22100/22120
- SDX 24100/24150
- SDX 25000-40G
- SDX 26000 (adapter required to connect 50G ports to 10G transceiver)
- SDX 26000-50S (adapter required to connect 50G ports to 10G transceiver)
- SDX 26000-100G (adapter required to connect 100G ports to 10G transceiver)

Field replaceable units

August 2, 2024

NetScaler field replaceable units (FRUs) are components that can be removed from the appliance and replaced by the user or a technician at the user's site. The FRUs in a NetScaler SDX appliance can include DC or AC power supplies, solid-state drives (SSDs), and a direct-attach cable (DAC).

All NetScaler FRUs must be purchased from Citrix. Components not provided by NetScaler are not supported on NetScaler appliances. Contact your NetScaler sales representative to buy FRUs for your appliance.

Note

The figures in this section are illustrative. The actual product might vary depending on the model number.

This topic includes the following sections:

- Power Supply
- Solid-State Drive
- Direct Attach Cable

Power supply

For appliances containing two power supplies, the second power supply acts as a backup. Some appliances can accommodate four power supplies, and require two power supplies for proper operation. The third and fourth power supplies act as backup. All power supplies must be of the same type (AC or DC).

The SDX appliance ships with a country-specific power cord and a plug.

For power-supply specifications, see the [SDX hardware platforms](#) topic, which describes the various platforms.

Note

If you suspect that a power-supply fan is not working, check the system health through the SDX GUI or lights out management. For more information, see [System Health Monitoring](#) and [Lights out management port of the NetScaler SDX appliance](#).

On each power supply, a bicolor LED indicator shows the condition of the power supply. Green means that the appliance receives power. Red means that the power supply has detected an error. For more information about the LED power supply indicator, see "LCD Display and LED Status Indicators" in [Common hardware components](#).

Electrical Safety Precautions for Power Supply Replacement

- Ensure that the appliance has a direct physical connection to earth ground during normal use. When installing or repairing an appliance, always connect the ground circuit first and disconnect it last.
- NetScaler SDX appliances do not contain user serviceable components, except as noted in the (FRU) section. Do not attempt to open the chassis.
- Always unplug the power cord from the power source before removing the power supply.
- Never touch a power supply when the power cord is plugged in. As long as the power cord is plugged in, line voltages are present in the power supply even if the power switch is turned off.

For the complete list of safety precautions, see [Safety, cautions, warnings, and other information](#).

Replace an AC or a DC power supply

If the appliance has only one power supply, you have to shut down the appliance before replacing the power supply. If the appliance has two power supplies, you can replace one power supply without shutting down the appliance, provided the other power supply is working.

To install or replace an AC or a DC power supply on a NetScaler SDX appliance

1. Align the semicircular handle perpendicular to the power supply. Loosen the thumbscrew and press the lever toward the handle and pull out the existing power supply, as shown in the following figure.

Figure 1. Remove an Existing AC Power Supply



Figure 2. Remove an Existing DC Power Supply



2. Carefully remove the new power supply from its box.
3. On the back of the appliance, align the power supply with the power supply slot.
4. Insert the power supply into the slot and press against the semicircular handle until you hear the power supply snap into place.

Figure 3. Insert the Replacement AC Power Supply



Figure 4. Insert the Replacement DC Power Supply



5. Connect the power supply to a power source. If connecting all power supplies, plug separate power cords into the power supplies and connect them to separate wall sockets.

Note

The NetScaler SDX appliance emits a high-pitched alert if the following conditions are met:

- One power supply fails.
- If you connect only one power cable to the appliance in which two power supplies are installed.

To silence the alarm, press the button labeled Alarm Disable on the back panel of the appliance. The **Disable alarm button** is functional only when the appliance has two power supplies.

Solid-State drives

In a NetScaler SDX appliance, the solid-state drives (SSD) store system bootup files and VDI of Management Service instances. Some support RAID and some do not.

SSDs with RAID support are hot swappable.

To replace a RAID-supported SSD

1. In the Management Service, navigate to **Configuration > System > RAID**.
2. On the **Physical Drives** tab, select the defective drive that you want to replace.
3. Click **Prepare to Remove** to trigger the removal of the drive.
4. Click **Physical Drives**. The state of the drive must now appear as **Not Present**.
5. Locate the SSD on the back panel of the appliance. Push the safety latch of the drive cover down while pulling out on the drive handle to disengage. Pull out the faulty drive.

Figure 5. Remove an Existing SSD

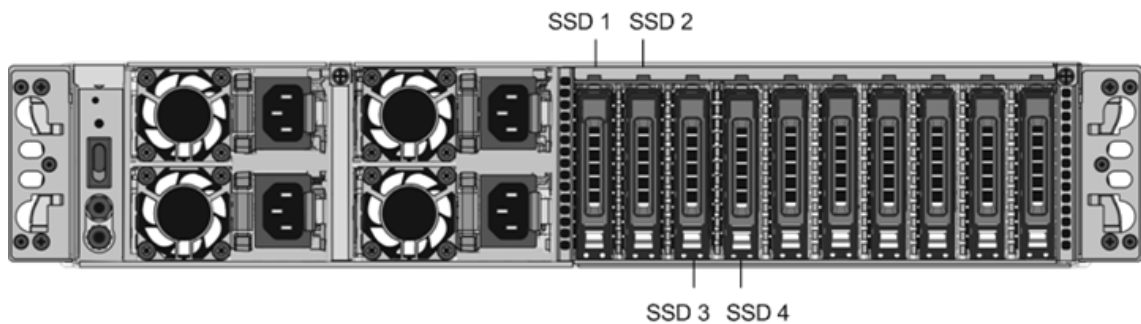

6. Verify that the replacement SSD is the correct size by comparing the replacement drive size with the removed drive. For example, if the removed drive is 480 GB, the replacement drive must also be 480 GB.
7. Open the drive handle fully up, and insert the new Citrix-certified SSD into the slot as far as possible. To seat the drive, close the handle flush with the rear of the appliance so that the drive locks securely into the slot.

When inserting the drive, orient the drive handle the same way as the installed drives.

Figure 6. Insert a Replacement SSD

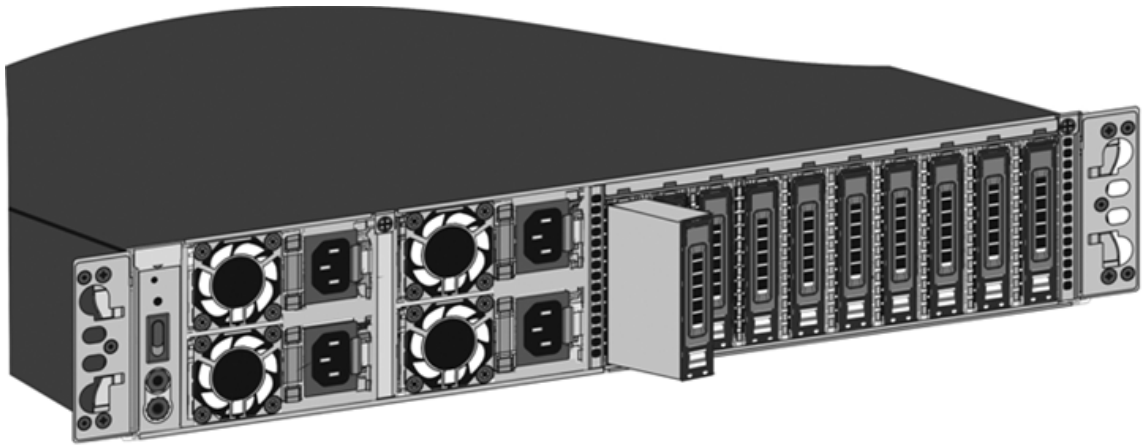

8. Click the refresh icon for the list of physical drives. The state of the drive must appear as Present.
9. Select the drive first and then click the **Rebuild** option. Click **OK** when the **Rebuild Physical Drive** dialog box is displayed. After you replace one of the SSDs, the configuration on the other SSD in the mirrored SSD is copied to the replacement SSD.

To replace an SSD without RAID support

1. From the NetScaler SDX GUI, navigate to **Configuration > System**, and in the System pane, click **Shutdown Appliance**.
2. Locate the SSD on the back panel of the appliance.
3. Press the latch release button, and the handle rotates out. Pull the handle to remove the drive.

Figure 7. Remove an Existing SSD without RAID

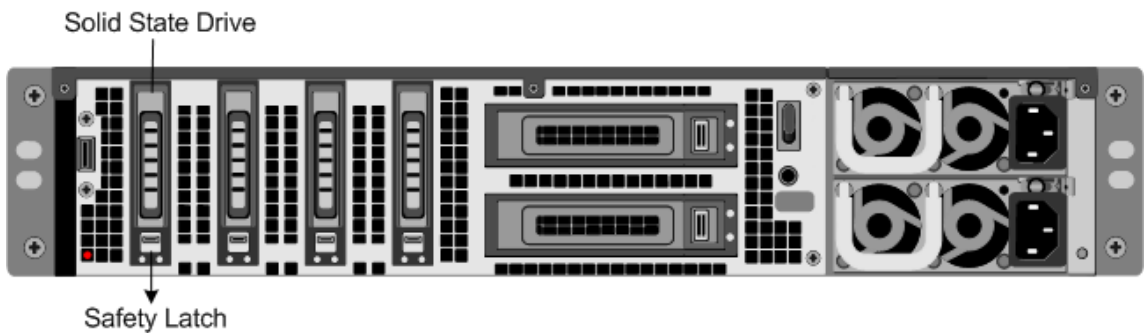

4. Verify that the replacement SSD is the correct size by comparing the replacement drive size with the removed drive. For example, if the removed drive is 480 GB, the replacement drive must be 480 GB.
5. Pick up the new SSD, open the drive handle fully to the left or up, and insert the drive into the slot as far as possible. To seat the drive, close the handle flush with the rear of the appliance so that the drive locks securely into the slot.

When inserting the drive, orient the drive handle the same way as the installed drives.

Figure 8. Insert a Replacement SSD without RAID

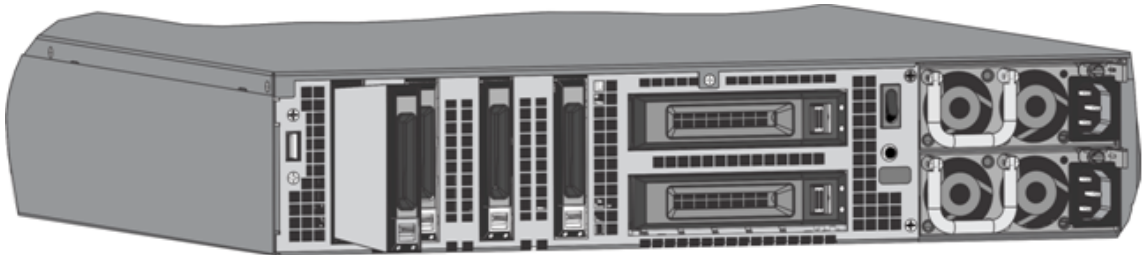

6. Turn on the appliance by manually pressing the power switch or by logging on to lights out management.
7. Log on to the default IP address by using a web browser, or connect to the serial console by using a console cable. Next, perform the initial configuration.
8. Upload a platform license and any optional feature licenses, including universal licenses, to the NetScaler appliance.
9. After the correct NetScaler software version is loaded, you can restore the working configuration.

Direct attach cable

A direct attach cable (DAC) assembly is a high performance integrated duplex data link for bi-directional communication. The cable is compliant with the IPF MSA (SFF-8432) for mechanical form factor and SFP+ MSA for DACs. The cable, which can be up to 5 meters long, is data-rate agnostic. Supporting speeds more than 10 Gbps, it is a cost-effective alternative to optical links (SFP+ transceivers and fiber optic cables.) The transceiver with DAC is hot-swappable. You can insert and remove the transceiver with the attached cable without shutting down the appliance. The NetScaler appliance supports only the passive DAC.

Points to note:

- DAC is supported only on 10G ports. Do not insert a DAC into a 1G port.
- Do not attempt to unplug the integrated copper cable from the transceiver and insert a fiber cable into the transceiver.

Note

Autonegotiation is not supported on an interface to which a DAC is connected.

To replace a DAC

1. To remove the DAC, pull the tab on the top of the DAC, and then pull the DAC out of the port.

Figure 9. Remove a DAC from the 10G port

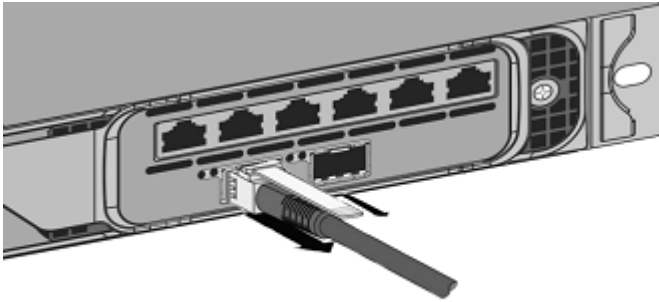

2. To insert the DAC, slide it into the 10G port on the appliance. You hear a click when the DAC properly fits into the port.

Figure 10. Insert a DAC into the 10G port

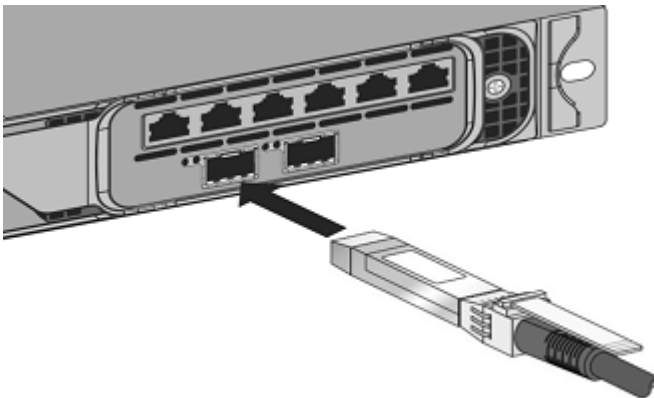

Safety, cautions, warnings, and other information

December 31, 2023

Read the safety and other compliance information before unpacking and installing the product. The safety and other compliance information remains the same for both SDX and MPX appliances. See the following documents:

- [Safety, cautions, warnings, and other information.](#)
- [Taiwan BSMI RoHS statement](#)

Note: For the list of safety certifications, standards, and ROHS compliance for each model, see the data sheet. The data sheet is available on www.netscaler.com. Navigate to **Platform > Form Factors > Hardware**.

- [FCC compliance statement](#)

Prepare for installation

June 19, 2024

Before you install your new appliance, carefully unpack your appliance and make sure that all parts were delivered. Verify that the location where the appliance is to be installed meets temperature and power requirements. Ensure that the server cabinet or floor-to-ceiling cabinet is securely bolted to the floor and has sufficient airflow.

Only trained and qualified personnel must install, maintain, or replace the appliance, and efforts must be taken to ensure that all cautions and warnings are followed.

This document includes the following details:

- Unpacking the appliance
- Preparing the site and rack
- Electrical safety precautions

Unpack the appliance

The hardware accessories for your particular appliance, such as cables, adapters, and rail kit, vary depending on the hardware platform you ordered. Unpack the box that contains your new appliance on a sturdy table with plenty of space and inspect the contents.

Verify that you received the cables, adapter, and rail kits specified for your appliance.

Note:

Make sure that a power outlet is available for each cable.

If the kit that you received does not fit your rack, contact your NetScaler sales representative to order the appropriate kit.

Transceiver modules are sold separately. Contact your NetScaler sales representative to order transceiver modules for your appliance. Only transceivers supplied by Citrix are supported on the appliance.

For Brazilian customers, NetScaler does not ship a power cable. Use a cable that conforms to the

ABNT NBR 14136:2002 standard.

In addition to the items included in the box with your new appliance, you need the following items to complete the installation and initial configuration process.

- Ethernet cables for each additional Ethernet port that you connect to your network
- One available Ethernet port on your network switch or hub for each NetScaler Ethernet port you want to connect to your network

Note: Transceiver modules are sold separately. Contact your NetScaler sales representative to order transceiver modules for your appliance. Only transceivers supplied by Citrix are supported on the appliance.

- A computer to serve as a management workstation

Prepare the site and rack

There are specific site and rack requirements for the NetScaler appliance. Ensure that adequate environmental control and power density are available. Racks must be bolted to the ground, have sufficient airflow, and have adequate power and network connections. Preparing the site and rack are important steps in the installation process and help ensure a smooth installation.

Site requirements

The appliance must be installed in a server room or server cabinet with the following features:

- **Environment control**

An air conditioner, preferably a dedicated computer room air conditioner (CRAC), capable of maintaining the cabinet or server room at a temperature of no more than 27 degrees C/80.6 degrees F at altitudes of up to 2100 m/7000 ft, or 18 degrees C/64.4 degrees F at higher altitudes, a humidity level no greater than 45 percent, and a dust-free environment.

- **Power density**

Wiring capable of handling at least 4000 watts per rack unit in addition to power needs **for** the CRAC.

Rack requirements

The rack on which you install your appliance must meet the following criteria:

- Rack characteristics

Racks must be either integrated into a purpose-designed server cabinet or be the floor-to-ceiling type, bolted down at both top and bottom to ensure stability. If you have a cabinet, it must be installed perpendicular to a load-bearing wall for stability and sufficient airflow. If you have a server room, your racks must be installed in rows spaced at least 1 meter/3 ft apart for sufficient airflow. Your rack must allow your IT personnel unfettered access to the front and back of each server and to all power and network connections.

- Power connections

At minimum, two standard power outlets per unit.

- Network connections

At minimum, four Ethernet connections per rack unit.

- Space requirements

One empty rack unit for the NetScaler SDX 8015/8400/8600, and two consecutive empty rack units for all other appliance models.

You can order the following rail kits separately.

- Compact 4-post rail kit, which fits racks of 23–33 inches.
- 2-post rail kit, which fits 2-post racks.

Electrical safety precautions

Read the caution and danger information you need to know, before unpacking and installing the product. For more information, see [Safety, cautions, warnings, and other information](#).

Install the hardware

June 19, 2024

Determining that the location where you plan to install your appliance meets the environmental standards and the server rack is in place according to the instructions. After you mount the appliance, you are ready to connect it to the network, to a power source, and to the console terminal that you will use for initial configuration. To complete the installation, you turn on the appliance. Be sure to observe the cautions and warnings listed with the installation instructions.

Note: Keep the serial number handy before you rack-mount the appliance. The serial number is the password for the first time logon to the appliance and can be found at the back of the appliance.

Rack-mount the appliance

Most appliances can be installed in standard server racks that conform to the EIA-310-D specification. The appliances ship with a set of rails, which you must install before you mount the appliance. The only tools that you need for installing an appliance are a Phillips screwdriver and a flathead screwdriver.

Caution: If you are installing the appliance as the only unit in the rack, mount it at the bottom. If the rack contains other units, make sure that the heaviest unit is at the bottom. If the rack has stabilizing devices available, install them before mounting the appliance.

To check the different hardware platforms and the rack units required for each platform, see the details given for each model under [SDX hardware platforms](#).

Each appliance ships with a mounting rail kit that contains two rail assemblies, one each for the left and the right side of the appliance, and screws to attach the rails. An assembly consists of an inner rail and a rack rail. The supplied rail kit is 28 inches long (38 inches extended). Contact your NetScaler sales representative to order a 23 inches (33 inches extended) rail kit.

Note: The same rail kit is used for both square-hole and round-hole racks. See To install the rack rails on the rack for specific instructions for threaded, round-hole racks.

To mount the appliance, you must first install the rails and then install the appliance in the rack.

Perform the following tasks to mount the appliance:

- Remove the inner rails from the rail assembly.
- Attach the inner rails to the appliance.
- Install the rack rails on the rack.
- Install the appliance in the rack.

The appliance is shipped with rack-rail hardware. This hardware consists of two inner rails that you attach to the appliance, one on each side, and a rack-rail assembly that you attach to the rack. The following figure illustrates the steps involved in mounting the NetScaler SDX appliance to a rack.

Remove the inner rails from the rail assembly

1. Place the rail assembly on a flat surface.
2. Slide out the inner rail toward the front of the assembly.
3. Press the latch until the inner rail comes all the way out of the rail assembly.
4. Repeat steps 1 through 3 to remove the second inner rail.

Attach the inner rails to the appliance

1. Position the right inner rail behind the handle on the right side of the appliance.
2. Align the holes on the rail with the corresponding holes on the side of the appliance.
3. Attach the rail to the appliance with the provided screws: 4 per side for a 1U appliance and 5 per side for a 2U appliance, as shown in the following figure.

Figure 1. Attaching inner rails



4. Repeat steps 1 through 3 to install the left inner rail on the other side of the appliance.

Install the rack rails on the rack

1. If you have a round-hole, threaded rack, skip to step 3.
2. Install square nut retainers into the front post and back post of the rack as shown in the following figures. Before inserting a screw, be sure to align the square nut with the correct hole for your 1U or 2U appliance. The three holes are not evenly spaced.

Figure 2. Installing Retainers into the Front Rack Posts

Install in this hole for a 2U appliance

Install in center hole for a 1U appliance

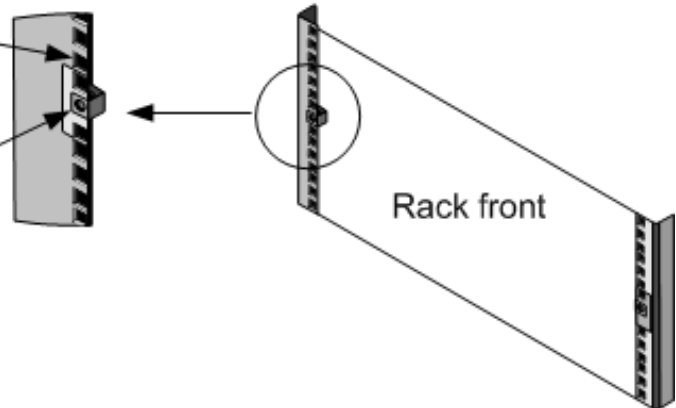
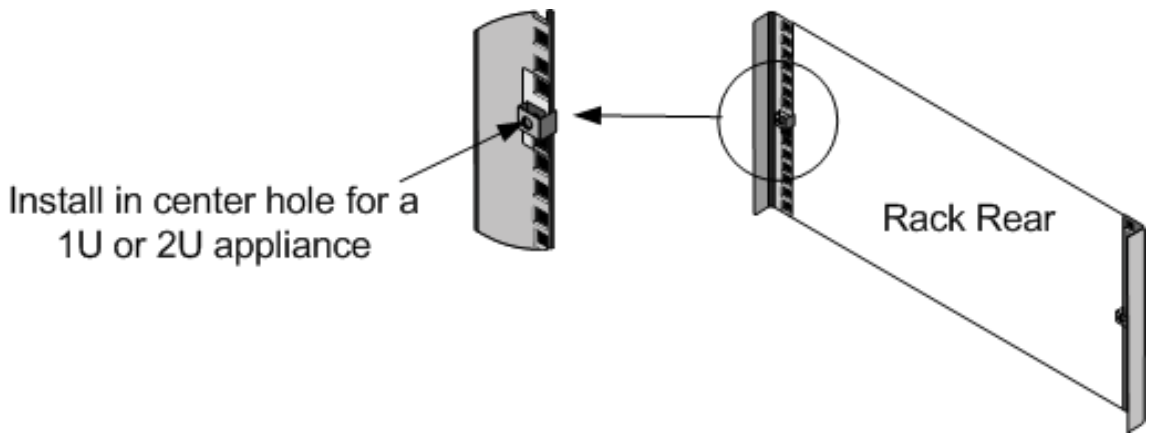
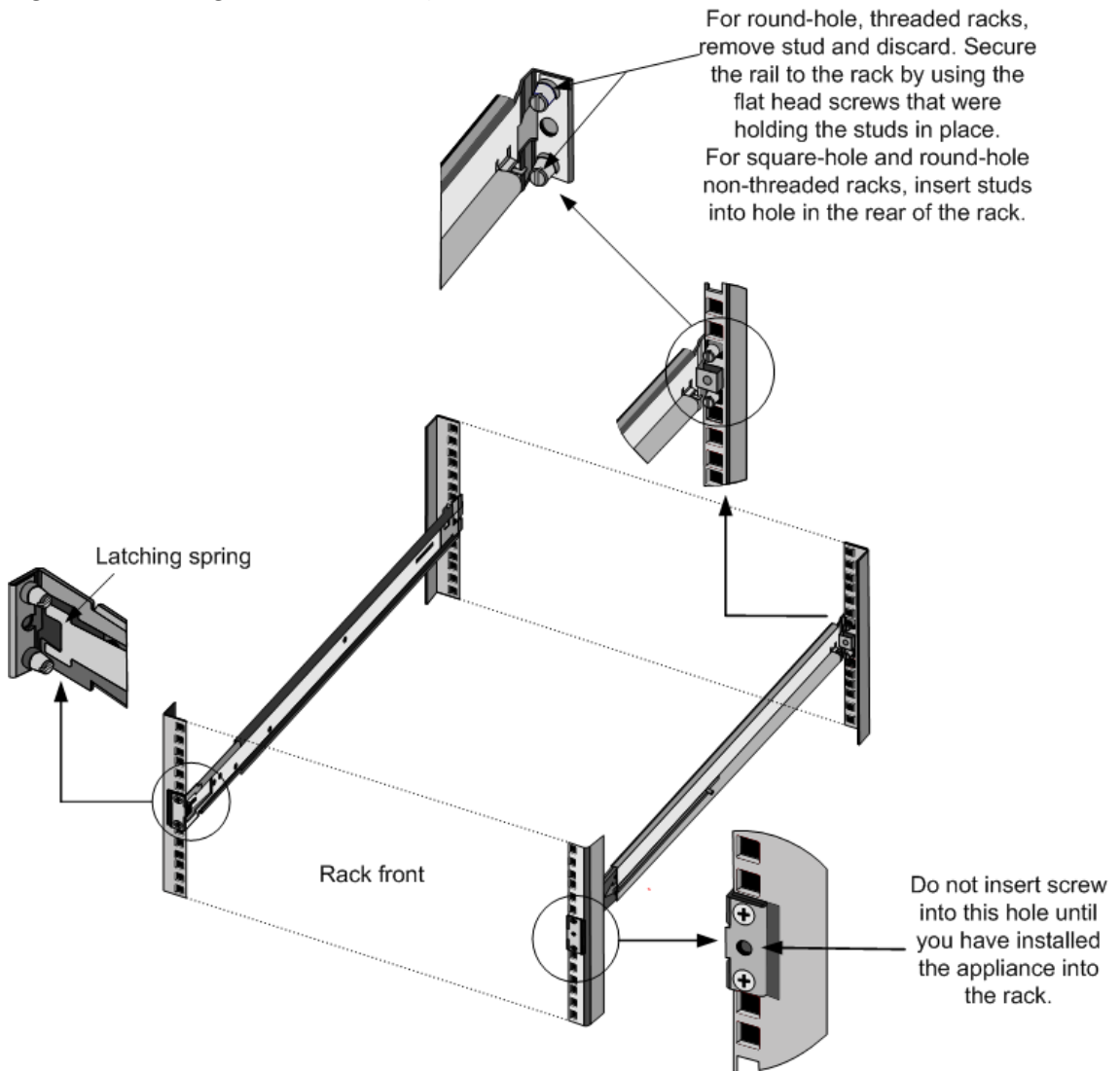

Figure 3. Installing Retainers into the Rear Rack Posts



3. Install the adjustable rail assembly into the rack as shown in the following figures. Use a screw to lock the rear rail flange into the rack. With the screw securing the rail in place, you can optionally remove the latching spring.

Figure 4. Installing the Rail Assembly to the Rack



Install the appliance in the rack

1. Align the inner rails, attached to the appliance, with the rack rails.
2. Slide the appliance into the rack rails, keeping the pressure even on both sides.
3. Verify that the appliance is locked in place by pulling it all the way out from the rack.

Figure 5. Rack Mounting the Appliance

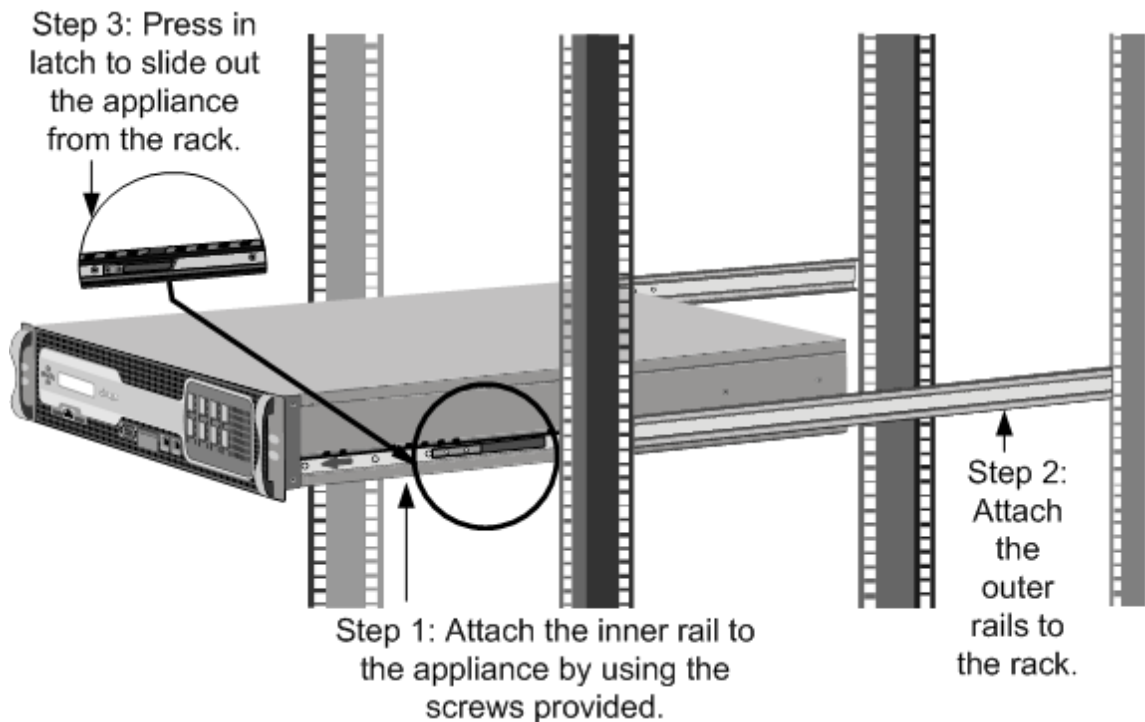

Watch this quick video about [how to rack mount a NetScaler hardware appliance](#).

Install and remove 1G SFP transceivers

A Small Form-Factor Pluggable (SFP) is a compact transceiver that can operate at speeds of up to 1 gigabit per second and is available in both copper and fiber types. Inserting a 1G SFP copper transceiver converts the 1G SFP port to a 1000BASE-T port. Inserting a 1G SFP fiber transceiver converts the 1G SFP port to a 1000BASE-X port. Auto-negotiation is enabled by default on the 1G SFP port into which you insert your 1G SFP transceiver. When a link between the port and the network is established, the speed and mode are matched on both ends of the cable.

Caution: NetScaler appliances do not support 1G SFP transceivers from vendors other than Citrix Systems. Attempting to install third-party 1G SFP transceivers on your NetScaler appliance voids the warranty.

Insert 1G SFP transceivers into the 1G SFP ports on the front panel of the appliance. Frequent installation and removal of transceivers shortens their life span. Follow the removal procedure carefully to avoid damaging the 1G SFP transceiver or the appliance.

Caution: Do not install the transceivers with the cables attached. Doing so can damage the cable, the connector, or the optical interface of the transceiver.

Install a 1G SFP transceiver

1. Remove the 1G SFP transceiver carefully from its box.
Danger: Do not look directly into fiber optic transceivers or cables. They emit laser beams that can damage your eyes.
2. Align the 1G SFP transceiver to the front of the 1G SFP transceiver port on the front panel of the appliance, as shown in the following figure.

Note

The illustration in the following figures might not represent your actual appliance.

Figure 6. Installing a 1G SFP transceiver

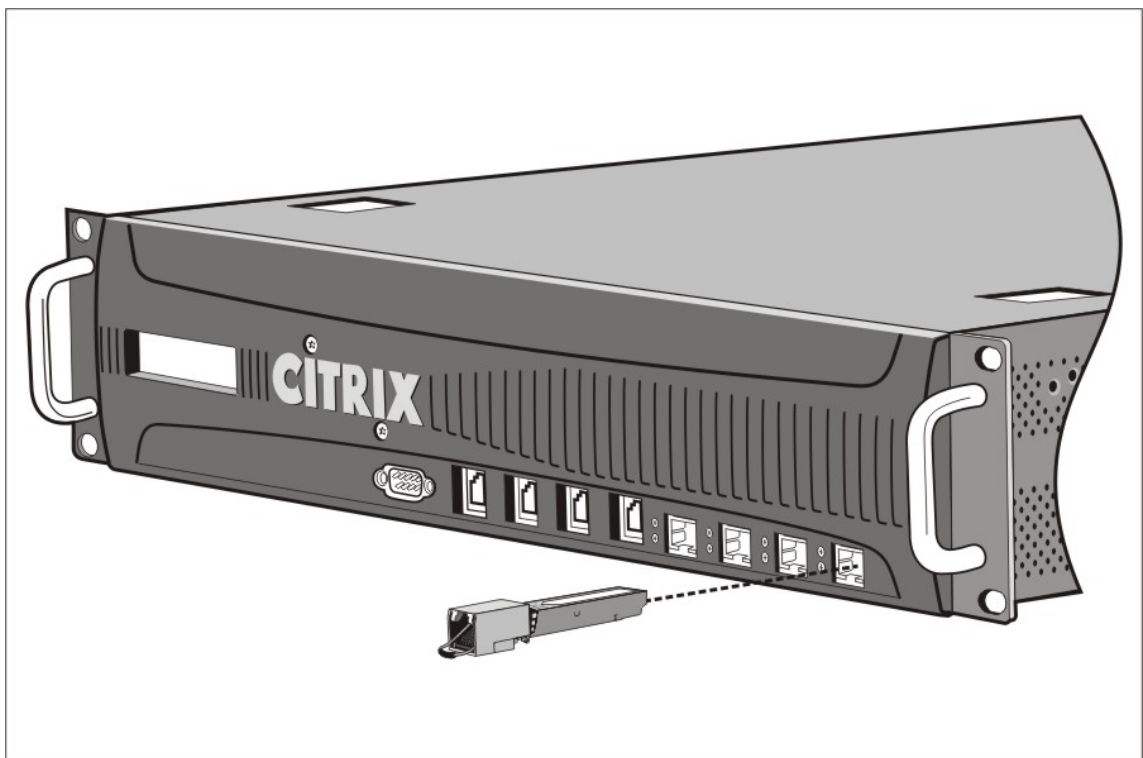

3. Hold the 1G SFP transceiver between your thumb and index finger and insert it into the 1G SFP transceiver port. Press it in until you hear the transceiver snap into place.

4. Lock the transceiver.
5. Verify that the LED is green and blinks twice, which indicates that the transceiver is functioning correctly.
6. When using a fiber 1G SFP transceiver, do not remove the dust caps attached to the transceiver and the cable until you are ready to insert the cable.

Remove a 1G SFP transceiver

1. Disconnect the cable from the 1G SFP transceiver. If you are using a fiber optic cable, replace the dust cap on the cable before putting it away.
Danger: Do not look directly into fiber optic transceivers or cables. They emit laser beams that can damage your eyes.
2. Unlock the 1G SFP transceiver.
3. Hold the 1G SFP transceiver between your thumb and index finger and slowly pull it out of the port.
4. If you are removing a fiber 1G SFP transceiver, replace the dust cap before putting it away.
5. Put the 1G SFP transceiver into its original box or another appropriate container.

Install and remove 10G SFP+ transceivers

A 10-Gigabit Small Form-Factor Pluggable (SFP+) is a compact optical transceiver that can operate at speeds of up to 10 gigabits per second. Autonegotiation is enabled by default on the 10G SFP+ ports into which you insert your 10G SFP+ transceiver. When a link between the port and the network is established, the mode is matched on both ends of the cable and for 10G SFP+ transceivers, the speed is also autonegotiated.

Caution: NetScaler appliances do not support 10G SFP+ transceivers provided by vendors other than Citrix Systems. Attempting to install third-party 10G SFP+ transceivers on your NetScaler appliance voids the warranty.

Insert the 10G SFP+ transceivers into the 10G SFP+ ports on the front panel of the appliance. Frequent installation and removal of transceivers shortens their life span. Follow the removal procedure carefully to avoid damaging the transceiver or the appliance.

Caution: Do not install the transceivers with the cables attached. Doing so can damage the cable, the connector, or the optical interface of the transceiver.

Install a 10G SFP+ transceiver

1. Remove the 10G SFP+ transceiver carefully from its box.

Warning: Do not look directly into fiber optic transceivers and cables. They emit laser beams that can damage your eyes.

2. Align the 10G SFP+ transceiver to the front of the 10G SFP+ transceiver port on the front panel of the appliance.
3. Hold the 10G SFP+ transceiver between your thumb and index finger and insert it into the 10G SFP+ transceiver port, pressing it in until you hear the transceiver snap into place.
4. Lock the transceiver.
5. Verify that the LED is green and blinks twice, which indicates that the transceiver is functioning correctly.
6. Do not remove the dust caps attached to the transceiver and cable until you are ready to insert the cable.

Remove a 10G SFP+ transceiver

1. Disconnect the cable from the 10G SFP+ transceiver. Replace the dust cap on the cable before putting it away.
Danger: Do not look directly into fiber optic transceivers or cables. They emit laser beams that can damage your eyes.
2. Unlock the 10G SFP+ transceiver.
3. Hold the 10G SFP+ transceiver between your thumb and index finger and slowly pull it out of the port.
4. Replace the dust cap on the transceiver before putting it away.
5. Put the 10G SFP+ transceiver into its original box or another appropriate container.

Connect the cables

When the appliance is securely mounted on the rack, you are ready to connect the cables. Ethernet cables and the optional console cable are connected first. Connect the power cable last.

Warning: Before installing or repairing the appliance, remove all jewelry and other metal objects that might come in contact with power sources or wires. When you touch both a live power source or wire and ground, any metal objects can heat up rapidly and cause burns, set clothing on fire, or fuse the metal object to an exposed terminal.

Connect the Ethernet cables

Ethernet cables connect your appliance to the network. The type of cable you need depends on the type of port used to connect to the network. Use a category 5e or category 6 Ethernet cable with

a standard RJ-45 connector on a 10/100/1000BASE-T port or 1G SFP copper transceiver. Use a fiber optic cable with an LC duplex connector with a 1G SFP fiber transceiver, 10G SFP+ transceiver. The type of connector at the other end of the fiber optic cable depends on the port of the device that you are connecting to.

Connect an Ethernet cable to a 10/100/1000BASE-T port or 1G SFP copper transceiver

1. Insert the RJ-45 connector on one end of your Ethernet cable into an appropriate port on the front panel of the appliance, as shown in the following figure.

Figure 7. Inserting an Ethernet cable

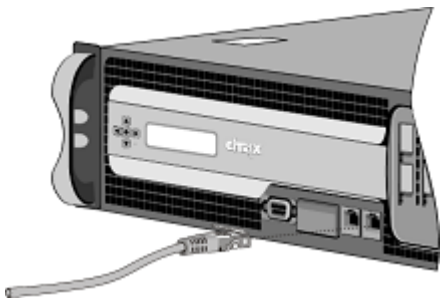

2. Insert the RJ-45 connector on the other end into the target device, such as a router or switch.
3. Verify that the LED glows amber when the connection is established.

Connect the Ethernet cable to a 1G SFP fiber, 10G SFP+ transceiver

1. Remove the dust caps from the transceiver and cable.
2. Insert the LC connector on one end of the fiber optic cable into the appropriate port on the front panel of the appliance.
3. Insert the connector on the other end into the target device, such as a router or switch.
4. Verify that the LED glows amber when the connection is established.

Connect the Console cable

You can use the console cable to connect your appliance to a computer or terminal, from which you can configure the appliance.

Alternatively, you can use a computer connected to the network. Before connecting the console cable, configure the computer or terminal to support VT100 terminal emulation, 9600 baud, 8 data bits, 1 stop bit, parity, and flow control set to NONE. Then connect one end of the console cable to the RS232 serial port on the appliance and the other end to the computer or terminal.

Connect the console cable to a computer or terminal

1. Insert the DB-9 connector at the end of the cable into the console port on the front panel of the appliance, as shown in the following figure.

Figure 8. Inserting a console cable

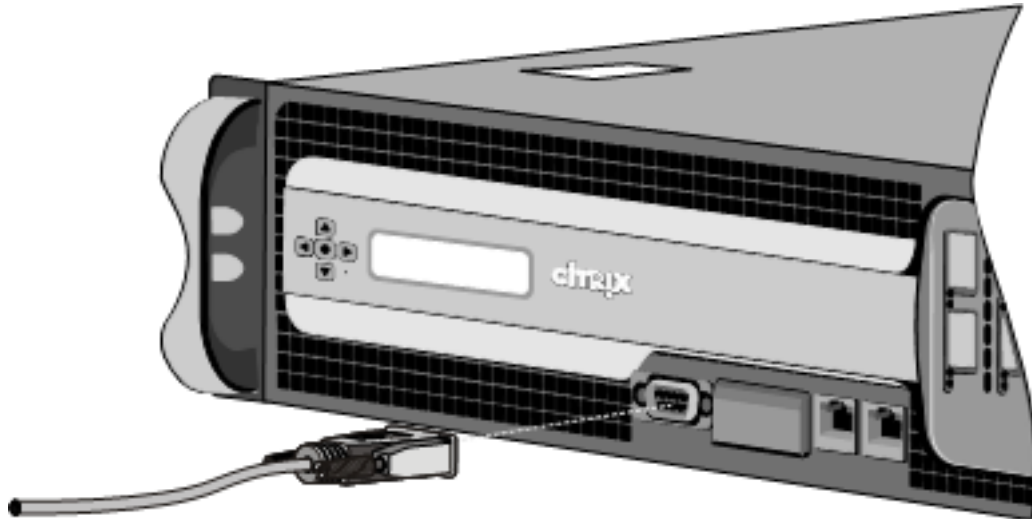

Note

To use a cable with an RJ-45 converter, insert the optional converter provided into the console port and attach the cable to it.

2. Insert the RJ-45 connector at the other end of the cable into the serial port of the computer or terminal.

Connect the power cable

An SDX 8015/8400/8600 appliance has one power cable. All the other appliances come with two power cables, but they can also operate if only one power cable is connected. A separate ground cable is not required, because the three-prong plug provides grounding.

Connect the appliance to the power source

1. Connect one end of the power cable to the power outlet on the back panel of the appliance, next to the power supply, as shown in the following figure.

Figure 9. Inserting a power cable

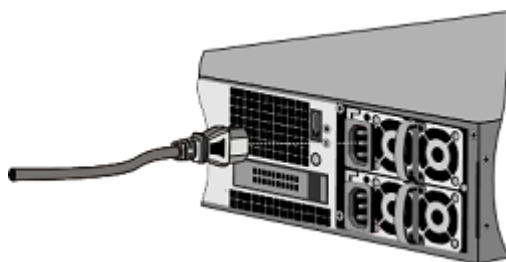

2. Connect the other end of the power cable to a standard 110V/220V power outlet.
3. If a second power supply is provided, repeat steps 1 and 2 to connect the second power supply.

Note

Some appliances emit a high-pitched alert if one power supply fails or if you connect only one power cable to the appliance. To silence the alarm, you can press the small red button on the back panel of the appliance.

Switch on the appliance

After you have installed the appliance in a rack and connected the cables, verify that the power cable is properly connected. If you have installed a second power supply, make sure that the second cable is connected to an outlet for a different circuit than the first. After verifying the connections, you are ready to switch on the appliance.

To switch on the appliance

1. Verify that the appliance is connected through a console or Ethernet port. This check ensures that you can configure the appliance after it is switched on.
2. Press the ON/OFF toggle power switch on the back panel of the appliance.

Caution: Be aware of the location of the emergency power off (EPO) switch, so that if an electrical accident occurs you can quickly remove power from the appliance.

Initial configuration

December 31, 2023

After you have installed your appliance in a rack, you are ready to perform the initial configuration. To perform the initial configuration, you can use the Management Service user interface or the serial console. You can access the Management Service user interface from any computer that is on the same network as the new SDX appliance. If you do not have a computer on the same network, use the serial console to perform the initial configuration of the SDX appliance. Citrix recommends that, when you complete the initial configuration, you change the root-user password. For information about changing the root-user password, see [Configuring Authentication and Authorization Settings](#).

Determine the following information for performing the initial configuration.

- NetScaler SDX IP address and subnet mask: The management IP address and the mask used to define the subnet in which the SDX appliance is located. This IP address is used to access the NetScaler SDX Management Service user interface.
- Citrix Hypervisor IP address: The IP address of the Citrix Hypervisor.
- Default gateway: The IP address of the router that forwards traffic out of the appliance's subnet. The default gateway must be in the same subnet as the NSIP address.
- Root password: The root user has full administrative privileges on the appliance. The root password is used to authenticate the root user. Change this password during the initial configuration of the appliance.

This topic includes the following sections:

- Initial Configuration through the Management Service User Interface
- Initial Configuration through the Serial Console
- Changing the Password of the Default User Account

Initial configuration through the Management Service user interface

To set up the appliance by using the Management Service user interface, connect a workstation or laptop to the same network as the appliance.

To configure the NetScaler SDX appliance by using the Management Service user interface

1. Connect the NetScaler SDX appliance to a management workstation or network by using interface 0/1.
2. Open a browser and type: <http://192.168.100.1>

Note: The NetScaler SDX Management Service is preconfigured with the IP address 192.168.100.1 and the Citrix Hypervisor is preconfigured with the IP address 192.168.100.2.

1. In **User Name**, type `nsroot`. In **Password**, if the earlier default password does not work, try typing the serial number of the appliance. The serial number bar code is available at the back of the appliance. Citrix recommends that you change the password after the first logon. For information about changing the password, see [Change the administrative password](#).
2. In the navigation pane, click **System**.
3. In the details pane, under **Setup Appliance**, click **Network Configuration**.
4. In the **Network Configuration** page, do the following:

a. In the **Interface** field, select the management interface that connects the appliance to a management workstation or network. Possible values: 0/1, 0/2. Default: 0/1.

Note: If you create an LA channel of the management ports, you can assign only one IP address to the channel. In the **Interface** field, only the LA channel option appears instead of 0/1 and 0/2. Also, even if both ports are connected, the Management Service is active only on one port.

b. In the **Appliance supportability IP** field, enter the IP address of the Citrix Hypervisor.

c. In the **Gateway** field, enter the IP address of the router that forwards traffic out of the appliance's subnet.

d. In the **DNS** field, enter the IPv4 address of the primary DNS server.

Note: IPv6 addresses are not support for the primary DNS server.

e. Select the IPv4 checkbox if you want to use the IPv4 address for the Management Service and enter the details for the following parameters:

i. **Appliance Management IP** —The IPv4 address that is used to access the Management Service by using a Web browser.

ii. **Netmask** —The mask used to define the subnet in which the SDX appliance is located.

f. Select the **IPv6** checkbox if you want to use the IPv6 address for the Management Service and enter the details for the following parameters:

i. **Management Service IP Address** —The IPv6 address that is used to access the Management Service by using a Web browser.

Note

The Citrix Hypervisor IP address and Management Service IP address must be in the same subnet.

ii. **Gateway IPv6 Address** —The IPv4 address of the router that forwards traffic out of the appliance's subnet.

g. Select the **Additional DNS checkbox** to add DNS server IP addresses as an extra DNS server apart from the primary DNS server. The IP addresses can be either IPv4 or IPv6.

Note:

Make sure that:

- You add a DNS server IP address or two DNS server IP addresses as an extra DNS server.
- You do not use the same DNS server IP address for the primary DNS server and extra DNS servers.
- Cascading of DNS servers for authentication, authorization, and auditing is not supported. For authentication, authorization, and auditing of LDAP referrals, RADIUS, and TACACS, the primary DNS server configured for address resolution is always considered for authentication, authorization, and auditing.

8. Click **OK**, and then click **Close**.

To confirm that the appliance is configured correctly, ping the new Management Service IP address or use the new IP address to open the user interface in a browser.

Note:

Log on to the NetScaler SDX appliance using the CLI, make sure that the file `/etc/resolv.conf` included the added extra DNS server IP addresses. Also, the `/mpsconfig/svm.conf` file reflects the added extra DNS server IP addresses.

For example:

```
1 /mps/changenameserver.sh 127.0.0.1
2 /mps/addnameserver.sh 1.2.3.4
```

Initial Configuration through the serial console

To perform the initial configuration of the SDX appliance from outside the L2 domain, connect to the console port of the appliance and follow the instructions carefully.

Note

The `networkconfig` utility is available from build 72.5 and later.

To configure the NetScaler SDX appliance by using the serial console

1. Connect the console cable into your appliance.
2. Connect the other end of the cable to your computer and run the vt100 terminal emulation program of your choice.
 - For Microsoft Windows, you can use HyperTerminal.
 - For Apple Macintosh OSX, you can use the GUI-based Terminal program or the shell-based telnet client.

Note: OSX is based on the FreeBSD UNIX platform. Most standard UNIX shell programs are available from the OSX command line.
 - To For UNIX-based workstations, you can use any supported terminal emulation program.
3. Press ENTER. The terminal screen displays the Logon prompt.

Note: You might have to press ENTER two or three times, depending on which terminal program you are using.
4. At the prompt, type: `ssh nsrecover@169.254.0.10` to log on to the Management Service. In **Password**, if the earlier default password does not work, try typing the serial number of the appliance. The serial number bar code is available at the back of the appliance. Citrix recommends that you change the password after the first logon. For information about changing the password, see [Change the administrative password](#).
5. Type `shell` to switch to the shell prompt and type `networkconfig`

You can now use the new IP address to log on to the Management Service user interface.

Change the password of the default user account

The default user account provides complete access to all features of the NetScaler SDX appliance. For security reasons, the administrator account must be used only when necessary, and only individuals whose duties require full access must know the password for the administrator account. Citrix recommends changing the administrator password frequently. If you lose the password, you can reset the password to the default by reverting the appliance settings to factory defaults, and you can then change the password.

You can change the password of the default user account in the **Users** pane. In the **Users** pane, you can view the following details:

- Name

Lists the user accounts configured on the SDX appliance.

- Permission

Displays the permission level assigned to the user account.

Change the administrative password by using the GUI

1. Log on to the appliance by using the administrative credentials.
2. Navigate to **System > User Administration > Users**.
3. In the **Users** pane, click the default user account, and then click **Modify**.
4. In the **Modify System User** dialog box, in **Password** and **Confirm Password**, enter the password of your choice.
5. Click **OK**.

For more information about more NetScaler SDX software configuration, see [NetScaler SDX software documentation](#).

Lights out management port of the NetScaler SDX appliance

May 29, 2024

The SDX ADC appliances have an Intelligent Platform Management Interface (IPMI), also known as the lights out management (LOM) port, on the front panel of the appliance. You can use the LOM port to remotely monitor and manage the appliance, independently of the NetScaler software.

By connecting the LOM port to a dedicated channel that is separate from the data channel, you can make sure that connectivity to the appliance is maintained even if the data network is down. Further you can reduce the data cable and data network as a single point of failure.

You can access the LOM port through a browser and use the GUI for most tasks. All tasks can be performed through the NetScaler shell.

You can use either the GUI or a shell for the following tasks:

- Configuring the network settings
- Health monitoring
- Power control operations
- Factory reset

Different NetScaler ADC appliances support different shells:

- For Citrix Hypervisor based NetScaler SDX appliances, use the dom0 Linux root shell. To access the dom0 shell, log on to the Citrix Hypervisor management IP address instead of the SDX Management Service IP address, using the `root` account, not the `nsroot` account.
- For Linux based appliances, use the Linux bash root shell.

Note

The terms LOM and Baseboard Management Controller (BMC) are used interchangeably.

Caution: LOM firmware versions are platform specific. Upgrading to a LOM firmware version other than the one shown for your platform in the LOM support matrix table, might result in the LOM becoming unusable.

LOM support matrix

The LOM support matrix shows the recommended LOM firmware version for different platforms.

Table. LOM support matrix

Hardware	Recommended Version
SDX 5900	4.61
SDX 8000	3.56
SDX 8900	4.61
SDX 9100	2.13.12
SDX 14000	4.14
SDX 14000-40S	4.14
SDX 14000 FIPS	4.14
SDX 14000-40G	4.14
SDX 15000	5.56
SDX 15000-50G	5.56
SDX 16000	2.13.12
SDX 25000A	4.14
SDX 25000TA	4.14
SDX 25000-40G	4.14
SDX 26000	5.56
SDX 26000-50S	5.56

Hardware	Recommended Version
SDX 26000-100G	5.56

Configure the network settings on the LOM port

August 23, 2024

The default IP address for initial access to the LOM port is 192.168.1.3. Change the default credentials and IP address the first time you log on. All LOM GUI operations require you to connect to the appliance by typing the LOM IP address in a web browser and then entering the administrator credentials. Alternatively, you can access LOM functionality through the command line by using the `ipmitool` utility. Using the `ipmitool` utility remotely, you can determine the LOM firmware version number, perform warm and cold restarts, configure LOM network settings, monitor the health of the appliance, and perform power control operations. The utility is available for download at <http://ipmitool.sourceforge.net/>. The `ipmitool` utility is also included in NetScaler MPX and Cloud-Bridge/SDX (dom0) appliances for initial LOM port network configuration. When using the shell, you can choose to use DHCP or static IP settings for initial network configuration. After configuring the network settings, you can use the `ipmitool` commands over the network. For example, the BMC firmware revision command would need the same user name, password, and IP address that is used to access the BMC/LOM GUI port.

For initial configuration, connect the network port on your laptop or workstation directly to the LOM port with a crossover cable, or to a switch in the same local subnet(192.168.1.x) as the LOM port. Assign a network-reachable IP address and change the default credentials. After saving the new settings, the LOM restarts and the changes take effect. After the restart, you must use the new address to access the LOM.

If you make a mistake that results in losing network connectivity at both the old and new IP addresses, you must use the local shell method to recover.

See the [Secure Deployment Guide](#) for best practices for managing administrative credentials and configuring your network for a secure LOM deployment.

Note

On all SDX platforms, except SDX 22040/22060/22080/22100/22120 and SDX 24100/24150, the LEDs on the LOM port are non-operational by design.

Tip: For first-time setup in a network, to facilitate troubleshooting, make sure that a laptop/PC is connected directly to the LOM port. If you can ping and access the LOM GUI at the default IP address (192.168.1.3) by using static addressing on the computer, but remote access does not work:

- Take a closer look at the network firewall settings and access control list (ACL) policies of all network devices along the network path.

Tip: If some LOM GUI features work but others do not (for example, normal NetScaler console output is visible in the NetScaler console window in the LOM GUI, but typing in the console does not work), try the preceding method to isolate the cause to the specific BMC protocol being blocked by the network.

Tip: Use the iKVM (HTML5) feature to access the LOM GUI. Alternately, use Java. Ensure that the latest Java updates are installed on your computer.

To configure the NetScaler LOM port by using the GUI

1. In a web browser, type <http://192.168.1.3> and enter the default user credentials. In Password, if the earlier default password does not work, try typing the serial number of the appliance. The serial number bar code is available at the back of the appliance.

Note

The NetScaler LOM port is preconfigured with IP address 192.168.1.3 and subnet mask 255.255.255.0.

See [Troubleshooting](#) if some of the options are grayed out.

2. On the **Configuration** tab, click **Network** and type new values for the following parameters:
 - IP Address—IP address of the LOM port.
 - Subnet Mask—Subnet mask used to define the subnet of the LOM port.
 - Default Gateway—IP address of the router that connects the LOM port to the network.
3. Click **Save**.
4. If you want to change the user credentials, navigate to **Configuration > Users**, select the user, click **Modify User**, and change the credentials.

To configure the NetScaler LOM port by using the shell

Note: You need superuser (admin) credentials to access the shell.

1. Configure the IP addressing mode:

- To use DHCP, at the shell prompt, type:

```
ipmitool lan set 1 ipsrc dhcp
```

No further IP-level configuration is required.

- To use static addressing, at the shell prompt type:

```
1 >ipmitool lan set 1 ipsrc static
2 >ipmitool lan set 1 ipaddr (LOM IP address)
3 >ipmitool lan set 1 netmask (netmask IP address)
4 >ipmitool lan set 1 defgw ipaddr <default gateway IP address>
```

The BMC reboots to apply the changes. Pings to the BMC succeed after approximately 60 seconds.

2. Optionally, to configure Ethernet VLAN ID and priority, at the NetScaler shell prompt type:

```
1 >ipmitool lan set 1 vlan id <off|ID>
2 >ipmitool lan set 1 vlan priority <priority>
```

You can either disable or enable the VLAN. Set the VLAN ID to a value from 1 to 4094, and the VLAN priority to a value from 0 to 7. After the network settings have been correctly applied, you can access the `ipmitool` remotely from a physically separate machine over the network. For remote access, enter the BMC user name, BMC password, and the BMC IP address. For example, to run the `ipmitool mc info` command, at the shell prompt on a remote machine, type:

```
ipmitool -U <username> -P <password> -H <bmc IP address> mc info
```

Obtain health monitoring information

There are two NetScaler MIBs: the NetScaler software management MIB and the NetScaler IPMI LOM hardware management MIB. The software management MIB is primarily used for monitoring the application software and the application software's utilization of hardware resources, such as CPU % and memory %. It provides a high level view of the appliance and is therefore suitable for the application monitoring function carried out by an application group within an organization. The LOM MIB is used for monitoring the hardware health and therefore provides a lower level view of the appliance. This type of monitoring is more applicable to the network monitoring function carried out by a network monitoring group.

The LOM SNMP traps in the LOM MIB report hardware failures. The NetScaler SNMP traps in the NetScaler MIB report software failures and hardware load issues.

The NetScaler MIB has a small subset of hardware sensors. It does not cover any BIOS level failures, because the BIOS checks the hardware primarily during boot time, before the NetScaler software starts. If the BIOS detects a failure, it does not load the boot loader. If the boot loader does not load, the

operating system does not load, and therefore the NetScaler SNMP software service responsible for sending the traps does not load.

The NetScaler software Management MIB issues a warning under the following conditions only:

1. If the failure is gradual enough for the main CPU to issue an SNMP alert. An electrical failure close to the CPU, such as a failed electrical capacitor, occurs too quickly for the CPU to issue an alert.
2. If the failure happens after the BIOS, Operating System, and SNMP service have started and normal boot-up has been successful.
3. If the failure happens while the operating system and other system software are in a stable enough state for the SNMP software service to run.

Whenever the NetScaler MIB is unable to report these warnings, because of hardware or software failure, the LOM MIB monitors and reports the warnings. The LOM microcontroller operates independently of the NetScaler software. To monitor the hardware and software of the NetScaler appliance, you must use both the NetScaler MIB and the LOM MIB.

The NetScaler IPMI LOM hardware management MIB SNMP firmware runs on the BMC microcontroller chip. The BMC chip CPU sends a warning in the case of a hardware failure, regardless of whether any of the preceding conditions occur. For example, if the BIOS halts the system during boot-up because of a memory DIMM failure, the BMC chip uses the BIOS POST code snooping mechanism to detect the failure, and sends a bad DIMM SNMP alert.

You can log on to the LOM port to view the health information about the appliance. All system sensor information, such as system temperature, CPU temperature, and status of fans and power supplies, appears on the sensor readings page. The Event Log records time stamps of routine events such as a power cycle, in addition to recording hardware-failure events. If SNMP traps are enabled, these events can be sent to your SNMP Network Monitoring software. For more information about how to set up an SNMP alert, see [Configuring SNMP Alerts](#).

To obtain health monitoring information

1. In the **Menu** bar, click **System Health**.
2. Under **Options**, click **Sensor Readings**.

Install the MIB

Download the IPMI SNMP management information base (MIB) for your LOM firmware version, and import it into the SNMP monitoring software.

For a sample configuration, see <http://www.net-snmp.org/tutorial/tutorial-5/commands/snmptrap.html>. For the exact steps of this procedure specific to your environment, contact your SNMP network monitoring software provider.

Configure SNMP Alerts

You can configure SNMP alerts on the LOM. Optionally, you can configure an alert to send emails.

To configure the alerts, you can use the LOM GUI or the NetScaler shell.

To configure SNMP alerts on the LOM by using the GUI

1. Download the IPMI View utility from <ftp://ftp.supermicro.com/utility/IPMIView/> and install it on your computer. Use this utility to test the configuration. For more information, see the section about configuring the alert settings in the IPMI View User Guide at <http://supermicro.com>.
2. Open the IPMI View utility.
3. In the LOM GUI, navigate to **Configuration > Alerts**, click **Alert No 1**, and then click **Modify**.
4. Select the severity level of the events for which to generate alerts.
5. Set Destination IP to the IP address at which you installed the IPMI View utility.
6. Optionally, to receive alerts by email, specify an email address. To avoid receiving email for routine alerts, specify a severity higher than Informational.
7. Click **Save**.
8. The LOM starts sending alerts to the IPMI View utility within a minute or two. After the IPMI View utility starts receiving alerts from the LOM, reconfigure the destination IP address to point to your SNMP Network Management Software, such as HP OpenView.

Set up SNMP alerts on the LOM by using the NetScaler shell

To customize your filter and policy settings, see the IPMI Specification 2.0 rev. 1.1 documentation.

The latest IPMI specifications are available from the IPMI section of the Intel website:

<http://www.intel.com/content/www/us/en/servers/ipmi/ipmi-specifications.html>

Usually, customization in the SNMP Network Management Software is the preferred method, because it can be done one time at a central location. Therefore, the following settings send all events for all sensors to the SNMP network management software. These events are low traffic events and therefore do not result in any significant network usage.

To set up SNMP filters to allow all events:

```
ipmitool raw 4 0x12 0x6 0x10 0x80 1 1 0 0xff 0xff 0xff 0xff 0xff 0xff  
0xff 0 0xff 0 0 0xff 0 0 0xff 0
```

To set up a policy list for all sensors and events:

```
ipmitool raw 4 0x12 9 0x10 0x18 0x11 0x81
```

To set up a destination IP address for an SNMP event:

```
ipmitool lan alert set 1 1 ipaddr <x.x.x.x>
```

Where, is the IP address to which the SNMP event must be sent.

To specify an SNMP community string name:

```
ipmitool lan set 1 snmp <community string>
```

Create and install an SSL certificate on SDX 9100 and SDX 16000

July 19, 2024

Use OpenSSL to create a key, generate a certificate signing request (CSR), and generate a self-signed SSL certificate. Use the LOM GUI to install the SSL certificate. After successful installation, the LOM GUI uses the new SSL certificate for secure connections.

Prerequisites

- Access to an SDX platform running FreeBSD or Linux machine with OpenSSL installed.
- Administrative access credentials (nsroot/password) to the LOM web interface.

Create an SSL certificate by using OpenSSL

Perform the following steps from OpenSSL:

1. Generate a 2048-bit RSA private key. Type: `openssl genrsa -out private_key.pem 2048`

A file named private_key.pem is created in the current directory containing the RSA private key.

2. Generate a CSR using this private key. Type: `openssl req -new -key private_key.pem -out request.csr`

Enter values for the following parameters:

- Country Name (2 letter code): For example, US
- State or Province Name (full name): For example, California
- Locality Name: For example, San Francisco
- Organization Name: For example, My Company

- Organizational Unit Name: For example, IT Department
- Common Name For example, yourname (or your server's hostname)
- Email Address: For example, admin@mycompany.com
- Challenge password: Leave blank
- Optional company name: Leave blank

A file named request.csr is created in the current directory containing the certificate signing request.

3. Generate a self-signed SSL certificate using the CSR and the private key. The certificate is valid for 365 days. Type: `openssl x509 -req -in request.csr -signkey private_key.pem -out lom_certificate.pem -days 365`

A file named lom_certificate.pem is created in the current directory containing the self-signed SSL certificate.

Install an SSL certificate by using the LOM GUI

1. Log in to the LOM web interface using the default administrator (`nsroot`) account.
2. Navigate to **Configuration > Network > SSL Certificates**.
3. In **New SSL Certificate**, click **Select File**.
4. Browse to the location of the certificate file (lom_certificate.pem).
5. In **New Private Key**, click **Select File**.
6. Browse to the location of the key file (private_key.pem).
7. Click **Upload**.

The BMC will reboot after uploading the SSL certificate and private Key to the LOM UI and the system is locked by default.

Check the SSL certificate details in the browser to confirm it matches the lom_certificate.pem you generated.

Example

```
1 [root@netscaler-sdx SSL_Cert]# openssl version
2 OpenSSL 1.0.2k-fips 26 Jan 2017
3 [root@netscaler-sdx SSL_Cert]# uname -a
4 Linux netscaler-sdx 4.4.0+2 #1 SMP Fri Apr 30 02:46:33 UTC 2021 x86_64
   x86_64 x86_64 GNU/Linux
5 [root@netscaler-sdx SSL_Cert]# cat /etc/centos-release
6 XenServer release 7.1.2 (xenenterprise)
7 [root@netscaler-sdx SSL_Cert]# openssl genrsa -out private_key.pem 2048
8 Generating RSA private key, 2048 bit long modulus
9 .....+++
10 .....+++
```

```
11 e is 65537 (0x10001)
12 [root@netscaler-sdx SSL_Cert]# ls
13 private_key.pem
14 [root@netscaler-sdx SSL_Cert]# openssl req -new -key private_key.pem -
    out request.csr
15 You are about to be asked to enter information that will be
    incorporated
16 into your certificate request.
17 What you are about to enter is what is called a Distinguished Name or a
    DN.
18 There are quite a few fields but you can leave some blank
19 For some fields there will be a default value,
20 If you enter '.', the field will be left blank.
21 -----
22 Country Name (2 letter code) [XX]:US
23 State or Province Name (full name) []:California
24 Locality Name (eg, city) [Default City]:Santa_Clara
25 Organization Name (eg, company) [Default Company Ltd]:CSG
26 Organizational Unit Name (eg, section) []:Engineering
27 Common Name (eg, your name or your server's hostname) []: cloud.com
28 Email Address []: none@cloud.com
29
30 Please enter the following 'extra' attributes
31 to be sent with your certificate request
32 A challenge password []:
33 An optional company name []:
34 [root@netscaler-sdx SSL_Cert]# ls
35 private_key.pem request.csr
36 [root@netscaler-sdx SSL_Cert]# openssl x509 -req -in request.csr -
    signkey private_key.pem -out lom_certificate.pem -days 365
37 Signature ok
38 subject=/C=US/ST=California/L=Santa_Clara/O=CSG/OU=Engineering/CN=cloud
    .com/emailAddress=none@cloud.com
39 Getting Private key
40 [root@netscaler-sdx SSL_Cert]# ls
41 lom_certificate.pem private_key.pem request.csr
42
43 [root@netscaler-sdx SSL_Cert]# openssl version
44 OpenSSL 1.0.2k-fips 26 Jan 2017
45 [root@netscaler-sdx SSL_Cert]# uname -a
46 Linux netscaler-sdx 4.4.0+2 #1 SMP Fri Apr 30 02:46:33 UTC 2021 x86_64
    x86_64 x86_64 GNU/Linux
47 [root@netscaler-sdx SSL_Cert]# cat /etc/centos-release
48 XenServer release 7.1.2 (xenenterprise)
49 [root@netscaler-sdx SSL_Cert]# openssl genrsa -out private_key.pem 2048
50 Generating RSA private key, 2048 bit long modulus
51 .....+++
52 .....+++
53 e is 65537 (0x10001)
54 [root@netscaler-sdx SSL_Cert]# ls
55 private_key.pem
56 [root@netscaler-sdx SSL_Cert]# openssl req -new -key private_key.pem -
    out request.csr
```

```

57 You are about to be asked to enter information that will be
    incorporated
58 into your certificate request.
59 What you are about to enter is what is called a Distinguished Name or a
    DN.
60 There are quite a few fields but you can leave some blank
61 For some fields there will be a default value,
62 If you enter '.', the field will be left blank.
63 -----
64 Country Name (2 letter code) [XX]:US
65 State or Province Name (full name) []:California
66 Locality Name (eg, city) [Default City]:Santa_Clara
67 Organization Name (eg, company) [Default Company Ltd]:CSG
68 Organizational Unit Name (eg, section) []:Engineering
69 Common Name (eg, your name or your server's hostname) []: cloud.com
70 Email Address []: none@cloud.com
71
72 Please enter the following 'extra' attributes
73 to be sent with your certificate request
74 A challenge password []:
75 An optional company name []:
76 [root@netscaler-sdx SSL_Cert]# ls
77 private_key.pem request.csr
78 [root@netscaler-sdx SSL_Cert]# openssl x509 -req -in request.csr -
    signkey private_key.pem -out lom_certificate.pem -days 365
79 Signature ok
80 subject=/C=US/ST=California/L=Santa_Clara/O=CSG/OU=Engineering/CN=cloud
    .com/emailAddress=none@cloud.com
81 Getting Private key
82 [root@netscaler-sdx SSL_Cert]# ls
83 lom_certificate.pem private_key.pem request.csr

```

Sample Private_Key.pem (2048 bits)

```

1 -----BEGIN RSA PRIVATE KEY-----
2 MIIIEogIBAAKCAQEAlW0N9EghsirHkPsgAiwXHuDnW6D0stwC9V7ZLu38g36pqYk
3 X1yh0N4yF61nCqS+Mfiu+plPEDbXc5dwtd7Le4JEW80FHko5mBz3Uj9MSenJTBVT
4 V1d+hyu82nR0VWdAxe72kPiiTG7PuM34ZZqeHuy+tLU9FkAXDtxyjLPf/TDJPQL/
5 7h1klnTW5t9s2rSXznj3jsX0g88xF8S/ksGP106F507XoZYtpafUB/SqfZuX95qv
6 12EbbusifBwrmKVd/Z5/FguSGCeszBmrCol0dfUT44LMRPP2zW0m60234j4Hm0uh
7 Z/qL34seA1SmIMHkr9K57VHWqWoc3NmTDK2n0wIDAQABAoIBAEaI7AVb50wLFZLC
8 caGU3nUeatYKa7fdQE7VvyGV2wbPwnnYA2NgfloxymOUfdvLLi6Ax8YL1IgeSPn
9 YLT5LmRm4Y3PhY7+yqEbS0PvzTs2uGbJykV4b6mu477bKe8GhnTokEtukm4yAKvj
10 zLVn3ywJ5Ru4UdWm+ztwpEK7JQiGvkoMSn7+qDhEAw5sw9cdCRxqLITm0xVhda5L
11 x0576NCAvSMCGlkwu9F6nnsCP2TIT6Do44AiERAQRudWVrNWNAbQQwQ+9Q0LRLIn
12 lg+h8UIzBdUo4+HPm6ewSKTM1VBtQWTrLzKSEatUoqxXBznx1FpPbjo0G5xcTnXS
13 pzoztIECGYEaxxV1c706Hcy56hNv1q4G1UYDhRvBMIyeCnZWrr5LFD0Q5v7I/azH
14 i2EN4B/XZEQjstGxjGzCUXwngZoMykth67+bfynGkuAzdDQFgTXZCT1LSGwbJJQw
15 XhMTkL9Qpc9F1pByeX3G/o5pBc4xtjInMqf1wPEFD14ujeE/WMC0eCsCgYEAwCU9
16 azqLK1LMPgjcmeP4ZL51xTVbaCzo5mreQAMoljxc4QDEW+HIK7/hhD57/MyA7Zya
17 6xIhIQ0q26xGV+MrJ9tWIhyUfoC07kV9jc0TcszaMAzNk0+vKVEwmvQC7833csC9

```

```
18 Tx/hS4jSiYkyqeIVYV0IZWjZvSlFqfmsZCl1UvkCgYAGSPolRkMQb8cqyaRNPb8/  
19 em9gA2lM9B0FNwkziRU9110yRzbnM041a0H54md1ZeV0nuohCcn0spu4rrlapZiY  
20 zbrF//ah6mwVbhMCakXI0e0PjI2iUP9Z6PZEKpYMNgf5ZyQGC999Z9e09FyDaP/t  
21 zHmotrM3Mfz8Q7ExRxwrcwKBgCwRnneUcszZ7ZwgvI/S9hBMg+haJ3/KJRSL2D0I  
22 RevHJmo4mdCVBSr7lEaXaip940gebe2SN+Tztyuw5GVN5dz7ULL6iRhGfrjTWuH  
23 iHlhAH3awd+SfBMW2vX/FxlW/PTlvcWDA1ImrFr9C5CpGMw+4SkZF9rYt3sNJy4  
24 YX9JAoGAbAKC332U9iTPXajrygPkAtDjJQXnwp0BAXHU9NxNHFO0X2gkU+RQSotC  
25 8muqyDgA0SLuagd0bAZS59wQCjTtHXB8WR5R5fri7a1MdmW+/0nhGG09CwV4Vw/n  
26 ZEFexXmC1uU01jfj0HtXrKgmkaIj/1e60tjr/r6UxV/vM900gtw=  
27 -----END RSA PRIVATE KEY-----
```

Sample request.csr

```
1 -----BEGIN CERTIFICATE REQUEST-----  
2 MIIC3DCCAcQCAQAwgZYxCzAJBgNVBAYTAlVTMRMwEQYDVQQIDApDYWxpZm9ybmlh  
3 MRQwEgYDVQQHDAtTYW50YV9DbGFyYTEMMAoGA1UECgwDQ1NHMRQwEgYDVQQLDAtF  
4 bmdpbmVlcmIuZzESMBAGA1UEAwwJY2xvdWQuY29tMSQwIgwYJKoZIhvcNAQkBFhVr  
5 aG9hLm5ndXllbkbjBjG91ZC5jb20wgGEiMA0GCSqGSIb3DQEBAQUAA4IBDwAwggEK  
6 AoIBAQCvBQ30SCGyKseQ+yACLbce4903DoM6y3AL1Xtku7fyDfmpirfXKE43jIX  
7 rWcKpL4x+K76mU8Qntdzl3C13st7gkRbw4UeSjmYHPdSP0xJ6clMFVNxV36HK7za  
8 dHRVZ0DF7vaQ+KJMbs+4zfhlp4e7L60tT0WQBc03HKOU9/9MMk9CX/uHWSwNbm  
9 32zatJf0ePe0xc6DzzEXxL+SwY/U7oXk7tehli2lp9QH9Kp9m5f3mq/XYRtu6yJ8  
10 HCuYpV39nn8WC5IYJ6zMGasKiXR19RPjiUxE8/bNbSbo7bfipgeY66Fn+ovfix4D  
11 VKYgweSv0rntUdapahzc2ZMMraftAgMBAAGgADANBgkqhkiG9w0BAQsFAAOCAQEA  
12 I9rsE/tsUgGNHzgsJ6Bq45a1AFN1hDS2IPuvEVl+3eGECR6ZRMxcHRn3ZGS0ISmD  
13 mYeTfzwxT/IcCRXbVqFvAPkdiRwZwDvCjDg3BN1petrSURbyYbd9BTRkthSn+N10  
14 9Szyik0EKbuHnQ9TbeCB0vAKpSFIz+jImfNYXYIlvFTsJRJaDFDN0Xlv6QgDAX2J  
15 qxjVai0isJVz5QXjzD/NpWtFFQJYbllphS4uXmMllg3sWaAI9LhfAd1wJC9uSr8R  
16 CZyqnV6UjC0AXMsBbchR2SNa5lWNBH6F9Kjv2StlrpglmJfq63MqDQLq3HFfKrfA  
17 aQi90lrjSMWkdIQX22pZxw==  
18 -----END CERTIFICATE REQUEST-----
```

Sample lom_certificate.pem

```
1 -----BEGIN CERTIFICATE-----  
2 MIIDqjCCApICcQDaiXN+twskSjANBgkqhkiG9w0BAQsFADCBljELMAkGA1UEBhMC  
3 VVMxExARBgNVBAgMCkNhbGlb3JuaWExFDASBgNVBAcMC1NhbnRhX0NsYXJhMQww  
4 CgYDVQQKDANDU0cxFDASBgNVBAsMC0VuZ2luZWVyaW5nMRIwEAYDVQQDDAljbG91  
5 ZC5jb20xJDAiBkqhkiG9w0BCQEFWtob2Eubmd1eWVuQGNsb3VkLmNvbTAeFw0y  
6 NDA2MTEwMjAxMDRaFw0yNTA2MTEwMjAxMDRaMIGWQswCQYDVQQGEwJVUzETMBEG  
7 A1UECAwKQ2FsaWZvcM5pYTEUMBIGA1UEBwwLU2FudGFfQ2xhcmExDDAKBgNVBAoM  
8 A0NTRzEUMBIGA1UECwwLRW5naW5lZXJpbmcxEjAQBgNVBAMMCW5sb3VkLmNvbTEk  
9 MCIGCSqGSIb3DQEJARYVa2hvYS5uZ3V5Z5W5AY2xvdWQuY29tMIIBIjANBgkqhkiG  
10 9w0BAQEFAAOCAQ8AMIIBCgKCAQEAlW0N9EghsirHkPsgAiwXHuPdNw6D0stwC9V7  
11 ZLu38g36pqYkX1yh0N4yF61nCqS+Mfiu+plPEDbXc5dwd7Le4JEW80FHko5mBz3  
12 Uj9MSenJTBVTV1d+hyu82nR0VWdAxe72kPiiTG7PuM34ZZqeHuy+tLU9FkAXDtxy  
13 jlpf/TDJPQL/7h1klntW5t9s2rSXznj3jsX0g88xF8S/ksGP106F507XoZYtpafU  
14 B/SqfZuX95qv12EbbusifBwrMKVd/Z5/FguSGCeszBmrCol0dfUT44lMRPP2zW0m  
15 60234j4Hm0uhZ/qL34seA1SmIMHkr9K57VHWqWoc3NmTDK2n0wIDAQABMA0GCSqG
```

```
16 SIb3DQEBCwUAA4IBAQBLojhxNsw24N0uTIQ3dJh6WZATiiBjw8kQyEJqyiB8oCm0
17 oAVleDAjI44C2ear1vj321yNQI6bmBGPffwUoIX6YMAfll6nJq0fl9+rJd1FYCCd
18 FIqt76sC9YTU8WL3j7X1LE2lhQj7RZUt321QcG30qxQoXlQIM5oP7q17WkmPY0tW
19 JQZ4LjQRGHtc9rDiSlkzeMeBgtG3HqdNSorn2S15JJf/4sm5JXQXd7GByicv9aNm
20 AagjqwlkziJUpL02r2bRX+3Qn0NE5WlxaYYisIPe9py3TsnLXHcrnTqrHbh6e4wc
21 +yF9+4nouCHPj0s2i0QV7koFHZ8lnEiUYaxYT8wL
22 -----END CERTIFICATE-----
```

Install a certificate and key on older platforms using the LOM GUI

July 18, 2024

Citrix recommends using HTTPS to access the LOM GUI. To use HTTPS, you must replace the default SSL certificate with one from a trusted certificate authority and upload a private key to the LOM GUI.

To encrypt SNMP alerts, set up an SSL certificate and private key. In the GUI, navigate to **Configuration > SSL Certification** and apply the SSL certificate and private key. See the NetScaler Secure Deployment Guide for more information about how to securely deploy the LOM in your network. To enable encryption and learn the security measures for LOM, see <http://support.citrix.com/article/CTX129514>.

If you make a mistake, you must restore the [BMC to the factory defaults](#) to erase the certificate and key.

Note

The certificate file must contain only the certificate. The certificate and key must not be in the same file. Make sure that the certificate contains only the certificate and that the key file contains only the key.

To upload a trusted certificate and private key by using the LOM GUI

1. Navigate to **Configuration > SSL Certification**.

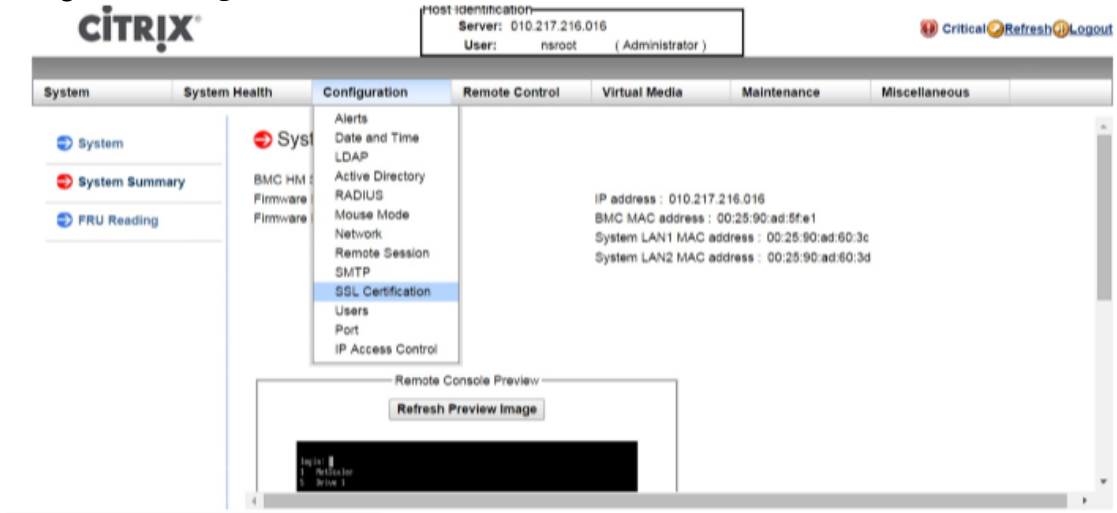

2. In the right pane, click the **Choose File** buttons to select a new SSL certificate and a new private key.

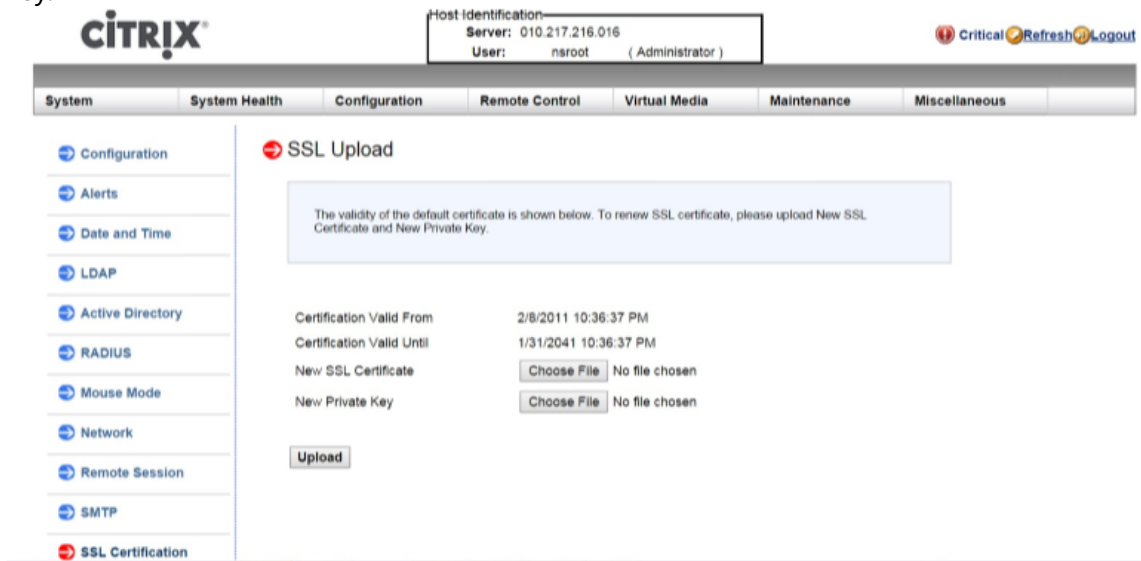

3. To verify that you have selected the correct certificate and private key, check the file names of the certificate and key. The file names appear next to the **Choose File** buttons.

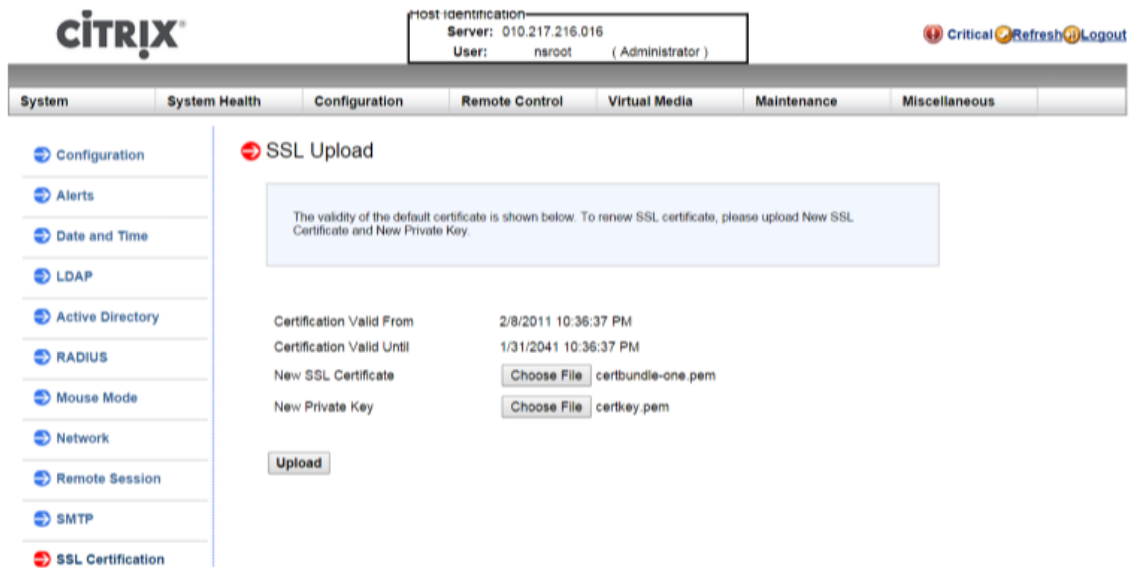

4. Click **Upload**. A message informs you that uploading a new SSL certificate replaces the existing (default) certificate.
5. Click **OK**.

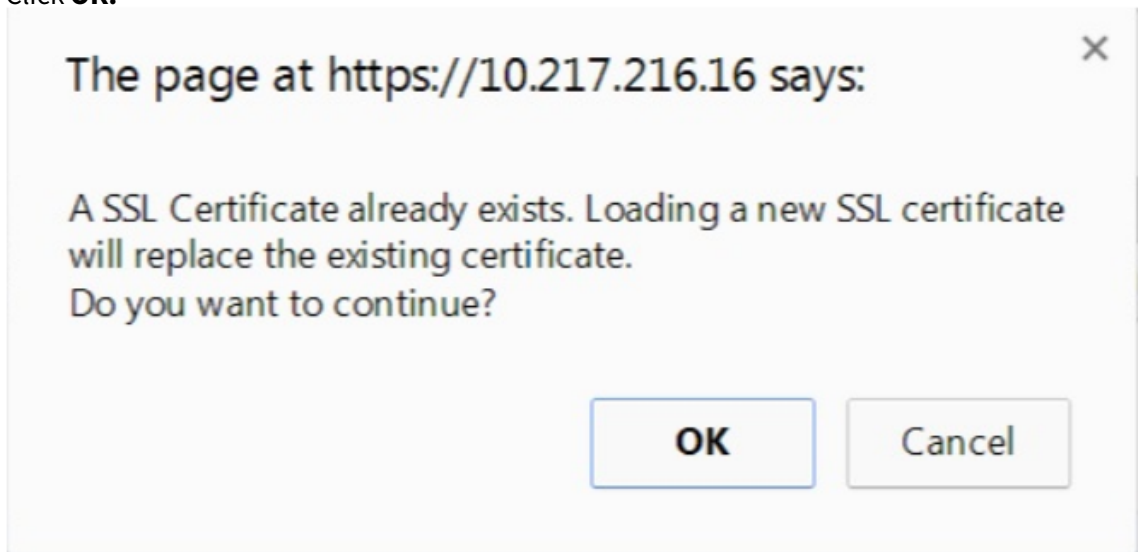

6. When a message informs you that the certificate and key have been uploaded successfully, click **OK** to reset the device.

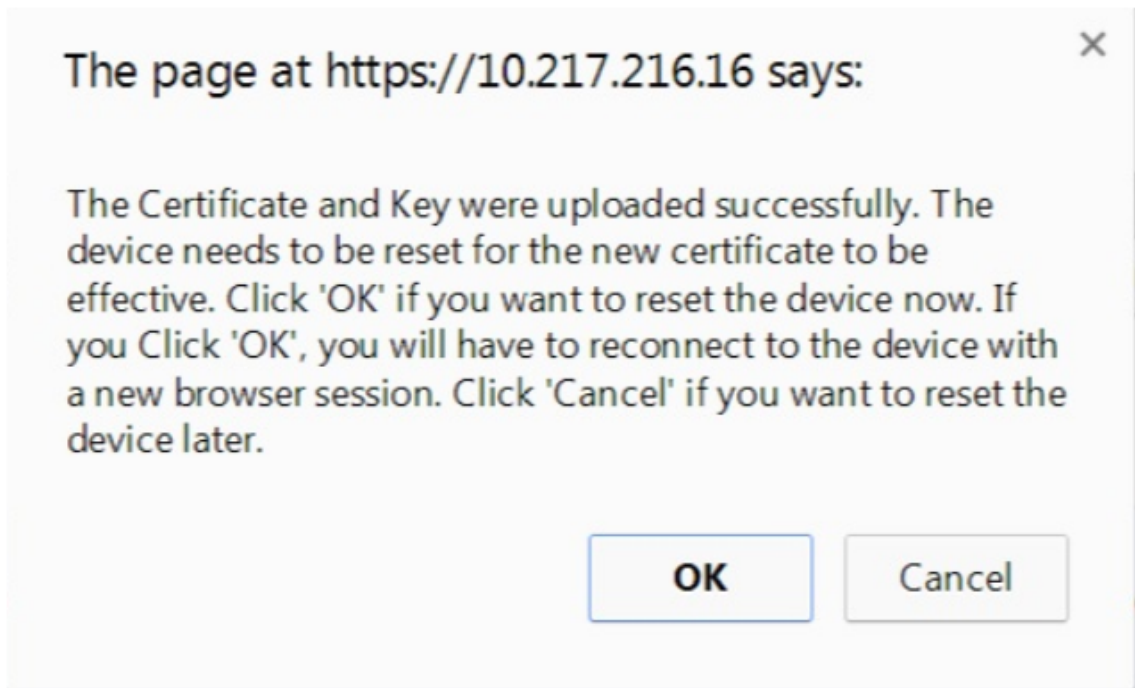

The reset takes approximately 60 seconds. You are then redirected to the logon page.



7. Log on to the LOM GUI by using your default credentials.

Note

If the certificate or key is invalid, the BMC reboots, tries the new settings, and reverts to using the previous settings.

8. In the address bar, click the lock icon to display the connection tab, as shown in the following screen.

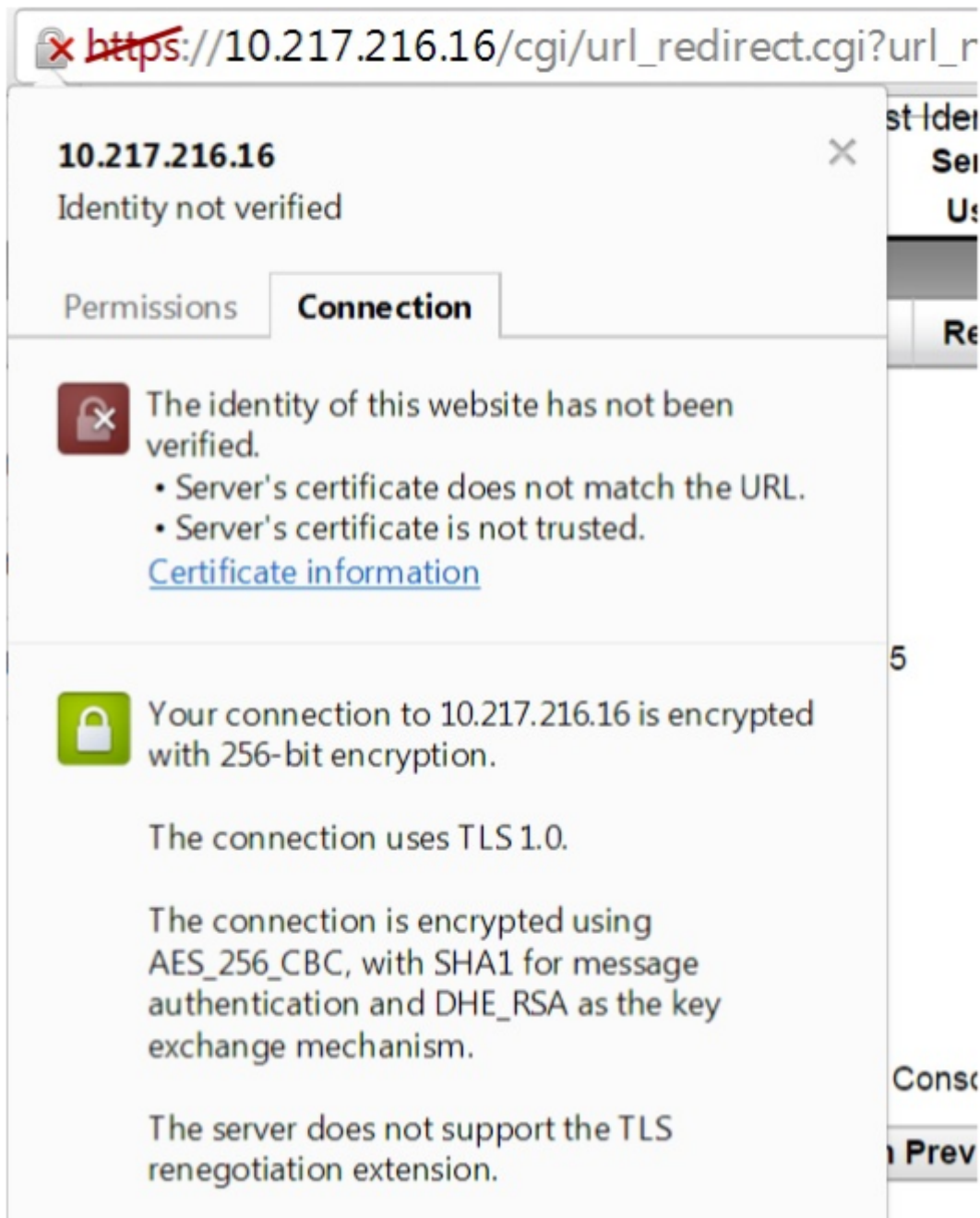

9. Click **Certificate** information to display details about the certificate that you uploaded.

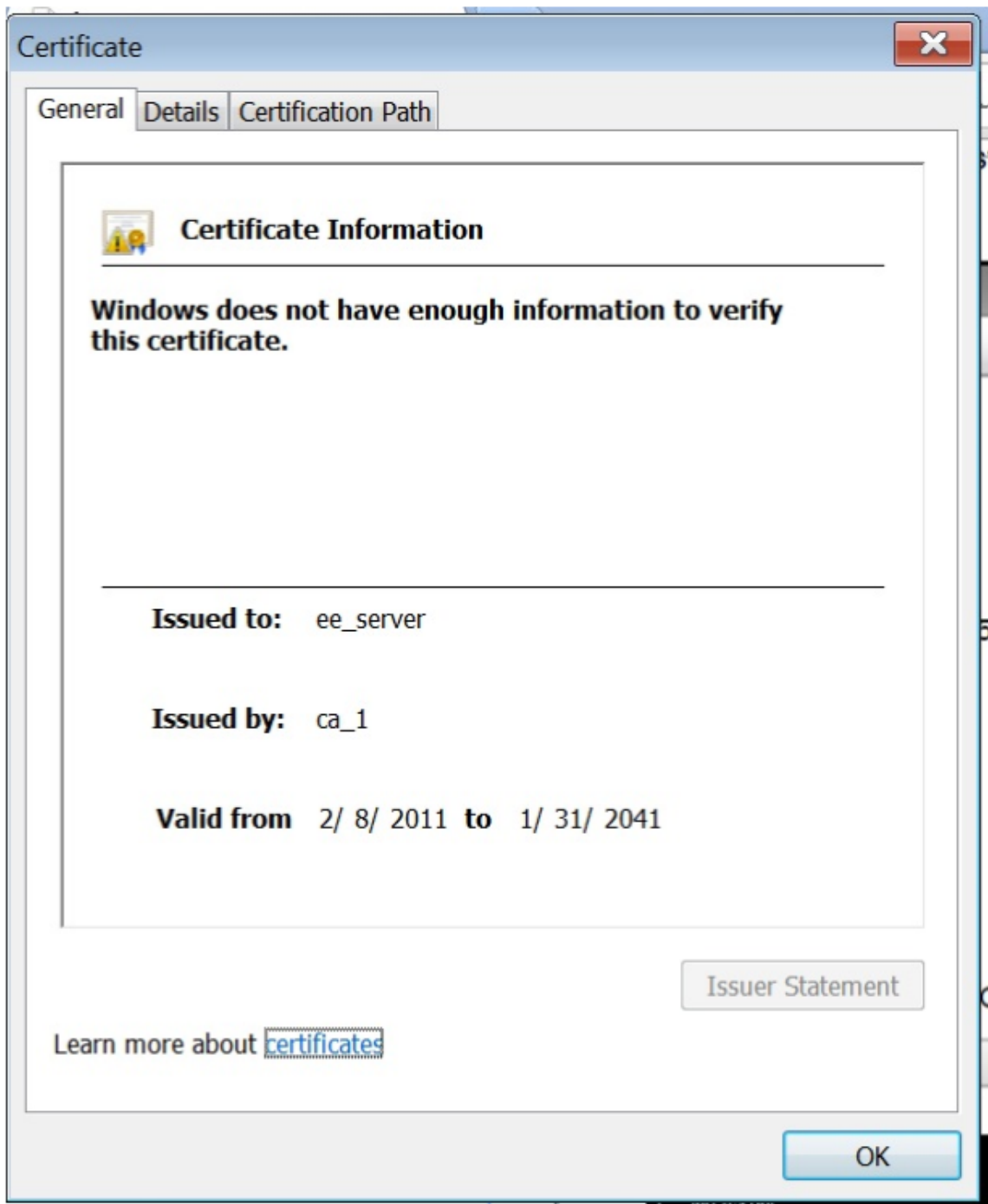

Note: For the best practices for LOM and NetScaler security, see <http://support.citrix.com/article/CTX129514>.

Obtaining the MAC address, serial number, and host properties of the appliance

December 31, 2023

A Media Access Control address (MAC address) is a unique identifier assigned to network interfaces for communication on the physical network segment. The serial number is on the back panel of the appliance. If you do not have easy access to the back panel, you can get the appliance's serial number by logging on to the LOM port. You can also retrieve the parameter settings assigned to the IP addresses configured on the appliance, such as the state of ARP, ICMP, telnet, secure shell access, and dynamic routing.

To obtain the MAC address, serial number, and host properties of the appliance by using the LOM GUI

1. In the **Menu** bar, click **Remote Control**.
2. Under **Options**, click **Console Redirection**.
3. Click **Launch Console**, and then click **Yes**.
4. Type the administrator credentials.
5. Type `show interface <management_interface_id>` to display the MAC address.
6. Type `show hardware` to display the serial number of the appliance.
7. Type `sh nsip` to display the host properties of the appliance.

To obtain the MAC address and host properties of the BMC by using the appliance shell

At the shell prompt, type:

```
ipmitool lan print
```

Example

```
1 Set in Progress           : Set Complete
2 Auth Type Support         : MD2 MD5 OEM
3 Auth Type Enable         : Callback : MD2 MD5 OEM
4                           : User      : MD2 MD5 OEM
5                           : Operator  : MD2 MD5 OEM
6                           : Admin    : MD2 MD5 OEM
7                           : OEM      :
8 IP Address Source         : Static Address
9 IP Address                : 192.168.1.3
10 Subnet Mask              : 255.255.255.0
```

```

11 MAC Address           : 00:25:90:3f:5e:d0
12 SNMP Community String : public
13 IP Header             : TTL=0x00 Flags=0x00 Precedence=0x00 TOS=0x00
14 BMC ARP Control       : ARP Responses Enabled, Gratuitous ARP
    Disabled
15 Gratuitous ARP Intrvl : 0.0 seconds
16 Default Gateway IP    : 0.0.0.0
17 Default Gateway MAC   : 00:00:00:00:00:00
18 Backup Gateway IP     : 0.0.0.0
19 Backup Gateway MAC    : 00:00:00:00:00:00
20 802.1q VLAN ID       : Disabled
21 802.1q VLAN Priority  : 0
22 RMCP+ Cipher Suites   : 1,2,3,6,7,8,11,12,0
23 Cipher Suite Priv Max : aaaaXXaaaXXaaXX
24                       : X=Cipher Suite Unused
25                       : c=CALLBACK
26                       : u=USER
27                       : o=OPERATOR
28                       : a=ADMIN
29                       : O=OEM

```

Perform power control operations by using the LOM port

December 31, 2023

Through the LOM port, you can remotely perform power control operations, such as graceful shut-down and restart, power cycling the appliance, and restarting the BMC microcontroller. A cold restart takes longer than a warm restart. In a cold restart, you switch off power to the appliance and then switch it back on.

Perform power control operations by using the GUI

1. In the **Menu** bar, click **Remote Control**.
2. Under **Options**, click **Power Control**, and then select one of the following options:
 - **Reset System**—Gracefully restart the appliance. All operations on the appliance are stopped, no new connections to the client or server are accepted, and all existing connections are closed before the appliance restarts. This option is similar to a warm restart, such as by entering the reboot command. The BMC does not reboot itself during this operation.
 - **Power Off System –Immediate**—Disconnect power to the appliance immediately, without gracefully shutting down the appliance. The BMC continues to operate normally in this mode to allow the user to remotely power on the appliance. This option is the same as pushing the power button until the unit powers off.

- **Power Off System –Orderly Shutdown**—Gracefully shut down the appliance, and then disconnect power to the appliance. Has the same effect as pressing the power button on the back panel of the appliance for less than four seconds. All operations on the appliance are stopped, no new connections to the client or server are accepted, and all existing connections are closed before the appliance shuts down. The BMC continues to operate normally in this mode to allow the user to remotely power on the appliance. This option is the same as entering the shutdown command in the appliance shell.
- **Power On System**—Switch on the appliance. The BMC does not reboot itself during this operation. This option is the same as pushing the power button.
- **Power Cycle System**—Switch off the appliance, and then turn it back on. The BMC does not reboot itself during this operation. This option is the same as pushing the power button until the unit powers off, and then pushing the power button to power on the unit.

3. Click **Perform Action**.

Perform a power cycle of the BMC

A warm restart, cold restart, or a power cycle of the appliance, using the power button, does not include power cycling the BMC. The BMC runs on standby power directly from the power supply. Therefore, the BMC is not affected by any state of the power button on the appliance. The only way to power cycle the BMC is to remove all power cords from the appliance for 60 seconds.

Perform power control operations on the BMC by using the appliance shell

When performing either a warm or cold restart of the BMC microcontroller, you cannot communicate with the LOM port. Both actions restart the BMC but not the main CPU. To perform a warm restart of LOM from the appliance, type:

```
ipmitool mc reset warm
```

Perform a warm restart remotely from another computer on the network

```
ipmitool -U <bmc_gui_username> -P <bmc_gui_password> -H <bmc IP address> mc reset warm
```

Perform a cold restart of the LOM from the appliance

```
ipmitool mc reset cold
```

Perform a warm restart remotely from another computer on the network

```
ipmitool -U <bmc_gui_username> -P <bmc_gui_password> -H <bmc IP  
address> mc reset cold
```

Perform a core dump

If the appliance fails or becomes unresponsive, you can remotely perform a core dump. This procedure has the same effect as pressing the **NMI** button on the back panel of the appliance.

Perform a core dump by using the GUI

1. In the **Menu** bar, click **Remote Control**.
2. Under **Options**, click **NMI**, and then click **Initiate NMI**.

Perform a core dump remotely from another computer on the network by using the shell

At the shell prompt, type:

```
ipmitool -U <bmc_gui_username> -P <bmc_gui_password> -H <bmc IP  
address> chassis power diag
```

Restoring the BMC configuration to factory defaults

December 31, 2023

You can restore the BMC to its factory-default settings, including deleting the SSL Certificate and SSL key.

To reset the configuration to factory defaults by using the GUI

1. Navigate to **Maintenance > Factory Default**.
2. Click **Restore**.

To reset the configuration to factory defaults by using the shell

At the shell prompt, type:

```
ipmitool raw 0x30 0x40
```

Specifying the port for IPMI BMC failover

December 31, 2023

With LOM firmware version 3.x or later, the default mode for failover between the dedicated LOM port and the shared LOM/management port is to fail over to the active port. By default, no user configuration is needed other than selecting the port to which to connect the cable. The motherboard has an Ethernet switch between the management MAC and the management port, and between the LOM MAC and the LOM port. The following figure shows the Ethernet switch.

Figure 1. Ethernet Switch

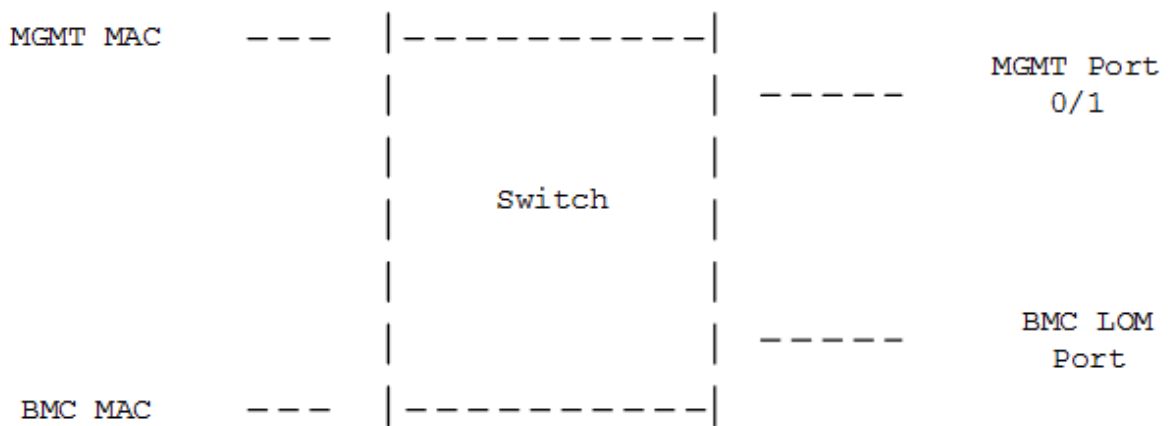

You can set this switch to direct LOM traffic through the dedicated LOM port or through the shared management port. A dedicated LOM port removes the management port as a single point of failure, while a shared LOM/management port reduces the cabling costs.

Using the BIOS POST code to detect errors

December 31, 2023

You can read the BIOS POST code by using the LOM GUI or the shell. To interpret the BIOS Beep codes, see https://www.supermicro.com/manuals/other/AMI_AptioV_BIOS_POST_Codes_for_SM_Motherboards.pdf.

To read the BIOS Post Code by using the LOM GUI

Navigate to **Miscellaneous > BIOS Post Snooping**.

To read the BIOS POST code by using the shell

At the prompt, type:

```
ipmitool raw 0x30 0x2a
```

Hardware health attributes of NetScaler SDX appliances

March 22, 2024

Operating ranges for NetScaler hardware platforms vary for different attributes.

Note

Use the `stat system -detail` command to display the current values of the attributes.

Health attributes for the SDX 9100 platform

The following table lists the health attributes for the SDX 9100 platform.

Health Attribute	Recommended Range
CPU Temp (Celsius)	10–95
PCH Temp (Celsius)	10–85
System Temp (Celsius)	10–80
Peripheral Temp (Celsius)	10–80
CPU_VRMIN Temp (Celsius)	10–95
VRMABCD Temp (Celsius)	10–95
VRMEFGH Temp (Celsius)	10–95
DIMMABCD Temp (Celsius)	10–80
DIMMEFGH Temp (Celsius)	10–80
System Fan 1 Speed (RPM)	1300–18000
System Fan 2 Speed (RPM)	1300–18000
System Fan 3 Speed (RPM)	1300–18000
System Fan 4 Speed (RPM)	1300–18000
System Fan 5 Speed (RPM)	1300–18000

Health Attribute	Recommended Range
System Fan 6 Speed (RPM)	1300–18000
Standby 3.3 V Supply (Volts)	2.885–3.69
+5.0 V Supply (Volts)	4.466–5.737
+12.0 V Supply (Volts)	10.704–13.476
VBAT (Volts)	2.591–3.464
3.3VSB (Volts)	2.954–3.552
5VSB (Volts)	4.496–5.378
1.8 V PCH (Volts)	1.618–1.943
PVNN PCH (Volts)	0.892–1.072
1.05 V PCH (Volts)	0.915–1.176
1.0 V BMC (Volts)	0.892–1.072
1.2 V BMC (Volts)	1.074–1.29
1.8 V BMC (Volts)	1.62–1.944
2.5 V BMC (Volts)	2.177–2.804
VcpuVRM (Volts)	1.616–1.944
vCPU (Volts)	0.931–1.195
VDimmABCD (Volts)	1.096–1.344
VDimmEFGH (Volts)	1.096–1.344

Health attributes for the SDX 8900 platform

The following table lists the health attributes for the SDX 8900 platform.

Health Attribute	Recommended Range
CPU 0 core (Volts)	1.77–1.81
Main 3.3 V Supply (Volts)	3.25–3.32
Standby 3.3 V Supply (Volts)	3.25–3.32
+5.0 V Supply (Volts)	4.84–4.95
+12.0 V Supply (Volts)	11.75–12.00

Health Attribute	Recommended Range
Battery (Volts)	3.02–3.13
5 V Standby (Volts)	5.05–5.16
CPU Fan 0 Speed (RPM)	6600–12600
CPU Fan 1 Speed (RPM)	6300–12200
System Fan Speed (RPM)	6700–8600
System Fan 1 Speed (RPM)	6600–8500
System Fan 2 Speed (RPM)	6700–8500
CPU 0 Temperature (Celsius)	40–57
CPU 1 Temperature (Celsius)	35–45
Internal Temperature (Celsius)	30–49
Power Supply 1 Status	NORMAL
Power Supply 2 Status	NOT PRESENT–NORMAL

Health attributes for the SDX 15000 and SDX 26000 platforms

The following table lists the health attributes for the SDX 15000 and SDX 26000 platforms.

Health Attribute	Unit	Minimum value	Nominal value	Maximum value
CPU 0 Core Voltage	Volt	1.47	1.82	1.835
CPU 1 Core Voltage	Volt	1.47	1.82	1.835
3_3VCC	Volt	3.12	3.30	3.48
3_3VSB	Volt	3.12	3.30	3.48
5VCC	Volt	4.72	5.00	5.28
p12V	Volt	11.33	12.00	12.67
VBAT	Volt	2.75	3.00	3.200
Vtt	-NA-	-NA-	-NA-	-NA-
5VSB	Volt	4.72	5.00	5.28
Voltage Sensor2	-NA-	-NA-	-NA-	-NA-

Health Attribute	Unit	Minimum value	Nominal value	Maximum value
CPU Fan 0 Speed	RPM	1500	-NA-	7500
CPU Fan 1 Speed	RPM	1500	-NA-	7500
System Fan Speed	RPM	1500	-NA-	7500
System Fan 1 Speed	RPM	1500	-NA-	7500
System Fan 2 Speed	RPM	1500	-NA-	7500
Fan 0 Speed	RPM	1500	-NA-	7500
CPU 0 Temp	Celsius	0	-NA-	85
CPU 1 Temp	Celsius	0	-NA-	85
Internal Temp	Celsius	0	-NA-	80

Health attributes for the SDX 14000 platform

The following table lists the health attributes for the SDX 14000 platform.

Health Attribute	Recommended Range
CPU 0 core (Volts)	0.85–0.91
CPU 1 core Volt	0.85–0.93
Main 3.3 V Supply (Volts)	3.31–3.36
Standby 3.3 V Supply (Volts)	3.26–3.31
+5.0 V Supply (Volts)	4.99–5.06
+12.0 V Supply (Volts)	11.98–12.08
Battery Voltage	3.02–3.12
Internal CPU Vtt Power	0.99–1.01
CPU Fan 0 Speed (RPM)	1875–4350
CPU Fan 1 Speed (RPM)	1875–4200
System Fan Speed (RPM)	1875–4350
System Fan 1 Speed (RPM)	1875–4275

Health Attribute	Recommended Range
System Fan 2 Speed (RPM)	1875–4200
CPU 0 Temperature (Celsius)	33–43
CPU 1 Temperature (Celsius)	35–45
Internal Temperature (Celsius)	28–38
Power Supply 1 Status	NORMAL
Power Supply 2 Status	NORMAL

Health attributes for the SDX 22040 platform

The following table lists the health attributes for the SDX 22040 platform.

Health attribute	Unit	Lower Non-Recoverable	Lower Critical	Lower Non-Critical	Upper Non-Critical	Upper Critical	Upper Non-Recoverable
CPU1 Temp	degrees C	0.000	0.000	0.000	90.000	93.000	95.000
CPU2 Temp	degrees C	0.000	0.000	0.000	90.000	93.000	95.000
System Temp	degrees C	-9.000	-7.000	-5.000	80.000	85.000	90.000
Peripheral Temp	degrees C	-9.000	-7.000	-5.000	80.000	85.000	90.000
PCH Temp	degrees C	-11.000	-8.000	-5.000	90.000	95.000	100.000
FPC_Temp 1	degrees C	• NA -	• NA -	• NA -	66.000	70.000	75.000
FPC_Temp 2	degrees C	• NA -	• NA -	• NA -	72.000	76.000	82.000
FPC_Temp 3	degrees C	• NA -	• NA -	• NA -	72.000	76.000	82.000
HDDBP_Temp 1	degrees C	• NA -	• NA -	• NA -	72.000	76.000	82.000
HDDBP_Temp 2	degrees C	• NA -	• NA -	• NA -	72.000	76.000	82.000
FAN 1	RPM	• NA -	1980.000	• NA -	• NA -	• NA -	• NA -

Health attribute	Unit	Lower		Lower	Upper		Upper
		Non-Recoverable	Lower Critical	Non-Critical	Non-Critical	Upper Critical	Non-Recoverable
FAN 2	RPM	• NA -	1980.000	• NA -	• NA -	• NA -	• NA -
FAN 3	RPM	• NA -	1980.000	• NA -	• NA -	• NA -	• NA -
FAN 4	RPM	• NA -	1980.000	• NA -	• NA -	• NA -	• NA -
FAN 5	RPM	• NA -	1980.000	• NA -	• NA -	• NA -	• NA -
FAN 6	RPM	• NA -	1980.000	• NA -	• NA -	• NA -	• NA -
FAN 7	RPM	• NA -	1980.000	• NA -	• NA -	• NA -	• NA -
FAN 8	RPM	• NA -	1980.000	• NA -	• NA -	• NA -	• NA -
PS_1 Status	discrete	• NA -	• NA -	• NA -	• NA -	• NA -	• NA -
PS_1 FAN	RPM	• NA -	• NA -	• NA -	• NA -	• NA -	• NA -
PS_1 Temp	degrees C	• NA -	• NA -	• NA -	• NA -	• NA -	• NA -
PS_2 Status	discrete	• NA -	• NA -	• NA -	• NA -	• NA -	• NA -
PS_2 FAN	RPM	• NA -	• NA -	• NA -	• NA -	• NA -	• NA -
PS_2 Temp	degrees C	• NA -	• NA -	• NA -	• NA -	• NA -	• NA -
PS_3 Status	discrete	• NA -	• NA -	• NA -	• NA -	• NA -	• NA -
PS_3 FAN	RPM	• NA -	1980.000	• NA -	• NA -	• NA -	• NA -
PS_3 Temp	degrees C	• NA -	• NA -	• NA -	72.000	76.000	82.000
PS_4 Status	discrete	• NA -	• NA -	• NA -	• NA -	• NA -	• NA -
PS_4 FAN	RPM	• NA -	1980.000	• NA -	• NA -	• NA -	• NA -
PS_4 Temp	degrees C	• NA -	• NA -	• NA -	72.000	76.000	82.000
FPC Status	discrete	• NA -	• NA -	• NA -	• NA -	• NA -	• NA -
VTT	Volts	0.816	0.864	0.912	1.344	1.392	1.440
CPU1 Vcore	Volts	0.480	0.512	0.544	1.488	1.520	1.552

Health attribute	Unit	Lower Non-Recoverable	Lower Critical	Lower Non-Critical	Upper Non-Critical	Upper Critical	Upper Non-Recoverable
CPU2 Vcore	Volts	0.480	0.512	0.544	1.488	1.520	1.552
VDIMM AB	Volts	1.104	1.152	1.200	1.648	1.696	1.744
VDIMM CD	Volts	1.104	1.152	1.200	1.648	1.696	1.744
VDIMM EF	Volts	1.104	1.152	1.200	1.648	1.696	1.744
VDIMM GH	Volts	1.104	1.152	1.200	1.648	1.696	1.744
+1.5 V	Volts	1.248	1.296	1.344	1.648	1.696	1.744
3.3 V	Volts	2.640	2.784	2.928	3.648	3.792	3.936
+3.3VSB	Volts	2.640	2.784	2.928	3.648	3.792	3.936
5 V	Volts	4.096	4.288	4.480	5.504	5.696	6.912
12 V	Volts	10.176	10.494	10.812	13.250	13.568	13.886
VBAT	Volts	2.400	2.544	2.688	3.312	3.456	3.600

Health attributes for SDX 24100 platform

The following table lists the health attributes for SDX 24100/24150.

Health attribute	Unit	Lower Non-Recoverable	Lower Critical	Lower Non-Critical	Upper Non-Critical	Upper Critical	Upper Non-Recoverable
CPU1 Temp	degrees C	0.000	0.000	0.000	90.000	93.000	95.000
CPU2 Temp	degrees C	0.000	0.000	0.000	90.000	93.000	95.000
System Temp	degrees C	-9.000	-7.000	-5.000	80.000	85.000	90.000
Peripheral Temp	degrees C	-9.000	-7.000	-5.000	80.000	85.000	90.000
PCH Temp	degrees C	-11.000	-8.000	-5.000	90.000	95.000	100.000

Health attribute	Unit	Lower Non-Recoverable	Lower Critical	Lower Non-Critical	Upper Non-Critical	Upper Critical	Upper Non-Recoverable
FPC_Temp 1	degrees C	• NA -	• NA -	• NA -	66.000	70.000	75.000
FPC_Temp 2	degrees C	• NA -	• NA -	• NA -	72.000	76.000	82.000
FPC_Temp 3	degrees C	• NA -	• NA -	• NA -	72.000	76.000	82.000
HDDBP_Temp 1	degrees C	• NA -	• NA -	• NA -	72.000	76.000	82.000
HDDBP_Temp 2	degrees C	• NA -	• NA -	• NA -	72.000	76.000	82.000
FAN 1	RPM	• NA -	1980.000	• NA -	• NA -	• NA -	• NA -
FAN 2	RPM	• NA -	1980.000	• NA -	• NA -	• NA -	• NA -
FAN 3	RPM	• NA -	1980.000	• NA -	• NA -	• NA -	• NA -
FAN 4	RPM	• NA -	1980.000	• NA -	• NA -	• NA -	• NA -
FAN 5	RPM	• NA -	1980.000	• NA -	• NA -	• NA -	• NA -
FAN 6	RPM	• NA -	1980.000	• NA -	• NA -	• NA -	• NA -
FAN 7	RPM	• NA -	1980.000	• NA -	• NA -	• NA -	• NA -
FAN 8	RPM	• NA -	1980.000	• NA -	• NA -	• NA -	• NA -
PS_1 Status	discrete	• NA -	• NA -	• NA -	• NA -	• NA -	• NA -
PS_1 FAN	RPM	• NA -	1980.000	• NA -	• NA -	• NA -	• NA -
PS_1 Temp	degrees C	• NA -	• NA -	• NA -	72.000	76.000	82.000
PS_2 Status	discrete	• NA -	• NA -	• NA -	• NA -	• NA -	• NA -
PS_2 FAN	RPM	• NA -	• NA -	• NA -	• NA -	• NA -	• NA -
PS_2 Temp	degrees C	• NA -	• NA -	• NA -	• NA -	• NA -	• NA -
PS_3 Status	discrete	• NA -	• NA -	• NA -	• NA -	• NA -	• NA -
PS_3 FAN	RPM	• NA -	• NA -	• NA -	• NA -	• NA -	• NA -
PS_3 Temp	degrees C	• NA -	• NA -	• NA -	• NA -	• NA -	• NA -

Health attribute	Unit	Lower	Lower	Lower	Upper	Upper	Upper
		Non-Recoverable	Critical	Non-Critical	Non-Critical	Critical	Non-Recoverable
PS_4 Status	discrete	• NA -	• NA -	• NA -	• NA -	• NA -	• NA -
PS_4 FAN	RPM	• NA -	• NA -	• NA -	• NA -	• NA -	• NA -
PS_4 Temp	degrees C	• NA -	• NA -	• NA -	• NA -	• NA -	• NA -
FPC Status	discrete	• NA -	• NA -	• NA -	• NA -	• NA -	• NA -
VTT	Volts	0.816	0.864	0.912	1.344	1.392	1.440
CPU1 Vcore	Volts	0.480	0.512	0.544	1.488	1.520	1.552
CPU2 Vcore	Volts	0.480	0.512	0.544	1.488	1.520	1.552
VDIMM AB	Volts	1.104	1.152	1.200	1.648	1.696	1.744
VDIMM CD	Volts	1.104	1.152	1.200	1.648	1.696	1.744
VDIMM EF	Volts	1.104	1.152	1.200	1.648	1.696	1.744
VDIMM GH	Volts	1.104	1.152	1.200	1.648	1.696	1.744
+1.5 V	Volts	1.248	1.296	1.344	1.648	1.696	1.744
3.3 V	Volts	2.640	2.784	2.928	3.648	3.792	3.936
+3.3VSB	Volts	2.640	2.784	2.928	3.648	3.792	3.936
5 V	Volts	4.096	4.288	4.480	5.504	5.696	6.912
12 V	Volts	10.176	10.494	10.812	13.250	13.568	13.886
VBAT	Volts	2.400	2.544	2.688	3.312	3.456	3.600

Hardware health attributes for the SDX 16000 platform

April 15, 2024

The following table lists the recommended ranges for the health attributes on the SDX 16000 platform.

Run the `ipmitool sdr list` command from the shell. This command lists the sensory parameters data in detail.

Run the `stat system -detail` command from the CLI. This command lists a subset of the parameters.

Health Attribute (shell)	Health Attribute (CLI)	Recommended Range
CPU1 Temp	CPU 0 Temperature (Celsius)	10–95
CPU2 Temp	CPU 1 Temperature (Celsius)	10–95
PCH Temp	Temperature 1 (Celsius)	10–85
System Temp	Internal Temperature (Celsius)	10–80
Peripheral Temp	Temperature 0 (Celsius)	10–80
Fan 1	CPU Fan 0 Speed (RPM)	1260–8260
Fan 2	CPU Fan 1 Speed (RPM)	1260–8260
Fan 3	System Fan Speed (RPM)	1260–8260
Fan 4	System Fan 1 Speed (RPM)	1260–8260
Fan 5	System Fan 2 Speed (RPM)	1260–8260
Fan 6	Fan 0 Speed (RPM)	1260–8260
12V	+12.0 V Supply Voltage	11.330–12.520
5VCC	+5.0 V Supply Voltage	4.713–5.217
3.3VCC	Main 3.3 V Supply Voltage	3.134–3.464
VBAT	Battery Voltage (Volts)	2.591–3.464
Vcpu1VCCIN	CPU 0 Core Voltage (Volts)	1.616–2.016
Vcpu2VCCIN	CPU 1 Core Voltage (Volts)	1.616–2.016
Vcpu1VDDQABCD	Voltage 0 (Volts)	1.096–1.344
Vcpu1VDDQEFGH	Voltage 1 (Volts)	1.096–1.344
Vcpu2VDDQABCD	Voltage 2 (Volts)	1.096–1.344
Vcpu2VDDQEFGH	Voltage 3 (Volts)	1.096–1.344
5VSB	5V Standby Voltage (Volts)	4.745–5.249
3.3VSB	Standby 3.3 V Supply Voltage	3.117–3.447
1.8V PCH	Voltage 4 (Volts)	1.698–1.883
PS1 Status	Power supply 1 status	• not applicable -

Health Attribute (shell)	Health Attribute (CLI)	Recommended Range
PS2 Status	Power supply 2 status	• not applicable -

Sample output

The following sections list the different ways to view the system sensor health attributes. The data is a sample representation only. The output from your appliance might be different. For the acceptable ranges, see the previous table.

- From the CLI
- From the shell
- From the LOM GUI

CLI

At the command line, type: `stat system -detail`

```

1 >stat system -detail
2
3 NetScaler Executive View
4
5 System Information:
6 Up since Tue Nov 15 13:50:59 2022
7 Up since(Local) Tue Nov 15 13:50:59 2022
8 Memory usage (MB) 3562
9 InUse Memory (%) 6.24
10 Number of CPUs 9
11
12 System Health Statistics (Standard):
13 CPU 0 Core Voltage (Volts) 1.77
14 CPU 1 Core Voltage (Volts) 1.77
15 Main 3.3 V Supply Voltage 3.49
16 Standby 3.3 V Supply Voltage 3.45
17 +5.0 V Supply Voltage 5.26
18 +12.0 V Supply Voltage 12.44
19 Battery Voltage (Volts) 3.11
20 Intel CPU Vtt Power(Volts) 0.00
21 5V Standby Voltage(Volts) 5.04
22 Voltage Sensor2(Volts) 0.00
23 CPU Fan 0 Speed (RPM) 3360
24 CPU Fan 1 Speed (RPM) 3360
25 System Fan Speed (RPM) 3360
26 System Fan 1 Speed (RPM) 3360
27 System Fan 2 Speed (RPM) 3360
28 CPU 0 Temperature (Celsius) 54
29 CPU 1 Temperature (Celsius) 53

```

```
30 Internal Temperature (Celsius)          33
31 Power supply 1 status                   NORMAL
32 Power supply 2 status                   NORMAL
33 Power supply 3 status                   NOT SUPPORTED
34 Power supply 4 status                   NOT SUPPORTED
35
36 System Disk Statistics:
37 /flash Size (MB)                        29748
38 /flash Used (MB)                        3927
39 /flash Available (MB)                   23441
40 /flash Used (%)                          14
41 /var Size (MB)                          800856
42 /var Used (MB)                          20127
43 /var Available (MB)                     716660
44 /var Used (%)                           2
45
46 System Health Statistics(Auxiliary):
47 Voltage 0 (Volts)                       1.20
48 Voltage 1 (Volts)                       1.20
49 Voltage 2 (Volts)                       1.20
50 Voltage 3 (Volts)                       1.20
51 Voltage 4 (Volts)                       1.88
52 Voltage 5 (Volts)                       0.00
53 Voltage 6 (Volts)                       0.00
54 Voltage 7 (Volts)                       0.00
55 Fan 0 Speed (RPM)                       3360
56 Fan 1 Speed (RPM)                       0
57 Fan 2 Speed (RPM)                       0
58 Fan 3 Speed (RPM)                       0
59 Temperature 0 (Celsius)                 28
60 Temperature 1 (Celsius)                 34
61 Temperature 2 (Celsius)                 0
62 Temperature 3 (Celsius)                 0
63 Done
64 >
```

Shell

At the command line, type: `shell`

```
1 > shell
2 root@ns# ipmitool sdr list
3
4 CPU1 Temp          | 54 degrees C      | ok
5 CPU2 Temp          | 53 degrees C      | ok
6 PCH Temp           | 34 degrees C      | ok
7 System Temp        | 33 degrees C      | ok
8 Peripheral Temp    | 28 degrees C      | ok
9 CPU1_VRMIN Temp    | 65 degrees C      | ok
10 CPU1_VRMIO Temp   | 44 degrees C      | ok
11 CPU2_VRMIN Temp    | 46 degrees C      | ok
12 CPU2_VRMIO Temp   | 47 degrees C      | ok
```

13	P1_VRMABCD Temp	38 degrees C	ok
14	P1_VRMEFGH Temp	43 degrees C	ok
15	P2_VRMABCD Temp	42 degrees C	ok
16	P2_VRMEFGH Temp	45 degrees C	ok
17	FAN1	3360 RPM	ok
18	FAN2	3360 RPM	ok
19	FAN3	3360 RPM	ok
20	FAN4	3360 RPM	ok
21	FAN5	3360 RPM	ok
22	FAN6	3360 RPM	ok
23	P1_DIMMA~D Temp	38 degrees C	ok
24	P1_DIMME~H Temp	33 degrees C	ok
25	P2_DIMMA~D Temp	30 degrees C	ok
26	P2_DIMME~H Temp	30 degrees C	ok
27	12V	12.44 Volts	ok
28	5VCC	5.26 Volts	ok
29	3.3VCC	3.49 Volts	ok
30	VBAT	3.11 Volts	ok
31	Vcpu1VCCIN	1.77 Volts	ok
32	Vcpu1VCCIO	1.00 Volts	ok
33	Vcpu2VCCIN	1.77 Volts	ok
34	Vcpu2VCCIO	1.00 Volts	ok
35	Vcpu1VDDQABCD	1.20 Volts	ok
36	Vcpu1VDDQEFGH	1.20 Volts	ok
37	Vcpu2VDDQABCD	1.20 Volts	ok
38	Vcpu2VDDQEFGH	1.20 Volts	ok
39	5VSB	5.04 Volts	ok
40	3.3VSB	3.45 Volts	ok
41	2.5V BMC	2.56 Volts	ok
42	1.8V BMC	1.83 Volts	ok
43	1.2V BMC	1.20 Volts	ok
44	1.0V BMC	1.02 Volts	ok
45	1.8V PCH	1.88 Volts	ok
46	PVNN PCH	1.06 Volts	ok
47	1.05V PCH	1.06 Volts	ok
48	PS1 Status	0x01	ok
49	PS2 Status	0x01	ok
50	AOC_NIC2 Temp	51 degrees C	ok
51	AOC_NIC4 Temp	51 degrees C	ok
52	root@ns#		

LOM GUI

1. Log on to the LOM GUI.
2. On the Dashboard, click **Sensor** for temperature and voltage values. Click **Fan** for fan values.

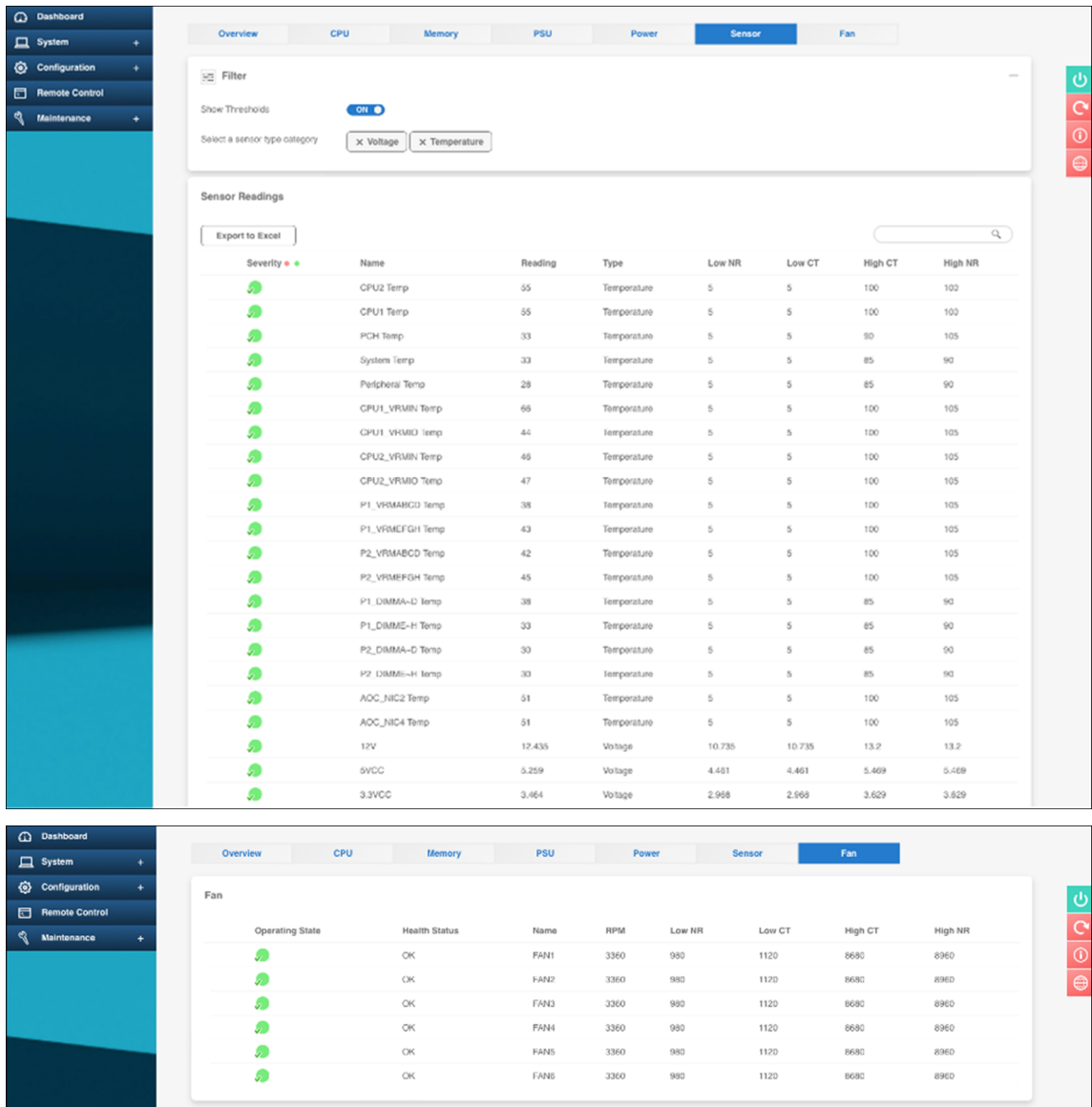

Fortville NIC firmware upgrade on NetScaler SDX appliances

December 31, 2023

Upgrade the firmware on NetScaler SDX appliances containing Fortville NICs to remediate <https://support.citrix.com/article/CTX263807>.

Supported platforms

Important: Before upgrading the single bundle image (SBI), first upgrade the VPX instance to one of the following releases:

- Release 11.1 build 65.x and later
- Release 12.1 build 57.x and later
- Release 13.0 build 58.x and later

The firmware and NIC driver are automatically upgraded to version 7.0 when the SDX SBI is upgraded to the following minimum versions. The time taken to complete the upgrade varies by platform. For example, on an SDX 14000 platform with 6 Fortville NICs, the total time to upgrade is around 30 min.

Software Version	SBI Version
11.1 build 65.x	11.1 build 65.x
12.1 build 57.x	12.1 build 57.x
13.0 build 58.x	13.0 build 58.x

The following SDX appliances and corresponding zero-capacity appliances contain Fortville NICs:

- SDX 8900
- SDX 14000-40S
- SDX 14000-40G
- SDX 15000
- SDX 15000-50G
- SDX 25000-40G
- SDX 26000
- SDX 26000-50S

Support for updated NIC driver and firmware on NetScaler SDX with 10G/25G/40G NICs

When you upgrade to Single Bundle Image (SBI) version 14.1-8.x and later or 13.1-50.x and later, the 10G/25G/40G NIC driver and firmware are automatically upgraded to version 8.70 on the following platforms. NIC firmware version 8.70 remediates CVE-2020-8690, CVE-2020-8691, CVE-2020-8692, and CVE-2020-8693.

- SDX 8900
- SDX 14000-40G
- SDX 15000

- SDX 15000-50G
- SDX 25000-40G
- SDX 16000
- SDX 9100
- SDX 26000
- SDX 26000-50S

Converting a NetScaler MPX appliance to a NetScaler SDX appliance

December 31, 2023

You can convert a NetScaler MPX appliance to an SDX appliance to deploy multiple virtualized ADC instances on a single, purpose-built physical appliance with full multiservice and multitenant support.

Note: Conversion of an SDX appliance to an MPX appliance is not supported.

You can convert the NetScaler MPX 11515/11520/11530/11540/11542 appliances to NetScaler SDX 11515/11520/11530/11540/11542 appliances. To convert, upgrade the software through a new Solid State Drive (SSD) and a new Hard Disk Drive (HDD).

The NetScaler models SDX 11515/11520/11530/11540/11542 are 2U appliances. Each model has two 6-core processors for a total of 12 physical cores (24 cores with hyper-threading), and 48 GB of memory.

The SDX 11515/11520/11530/11540/11542 appliances have the following ports:

- RS232 serial console port.
- 10/100Base-T copper Ethernet Port (RJ45), also called the LOM port. You can use this port to remotely monitor and manage the appliance independently of the NetScaler software.

Note:

On the SDX 11515/11520/11530/11540/11542 appliances, the LEDs on the LOM port are not operational, by design.

- Two 10/100/1000Base-T copper Ethernet management ports (RJ45), numbered 0/1 and 0/2 from left to right. These ports are used to connect directly to the appliance for system administration functions. Eight 10G SFP+ ports and four copper or fiber 1G SFP ports.

You can convert the NetScaler MPX 8005/8010/8015/8200/8400/8600/8800 appliances to NetScaler SDX 8010/8015/8400/8600 appliances by upgrading the software through a new Solid State Drive (SSD).

The NetScaler models SDX 8010/8015/8400/8600 are 1U appliances. Each model has one quad-core processor (8 cores with hyper-threading) and 32 GB of memory. The SDX 8010/8015/8400/8600 appliances are available in two port configurations:

- Six 10/100/1000Base-T copper Ethernet ports and six 1G SFP ports (6x10/100/1000Base-T copper Ethernet ports + 6x1G SFP)
- Six 10/100/1000Base-T copper Ethernet ports and two 10G SFP+ ports (6x10/100/1000Base-T copper Ethernet ports + 2x10G SFP+)

Convert a NetScaler MPX 26000-50S appliance to a NetScaler SDX 26000-50S appliance

August 6, 2024

You can convert a NetScaler MPX appliance to an NetScaler SDX appliance by upgrading the software through a new solid-state drive (SSD). NetScaler supplies a field conversion kit to migrate a NetScaler MPX appliance to an SDX appliance.

The conversion requires all eight SSDs.

Note:

Citrix recommends that you configure the lights out management (LOM) port of the appliance before starting the conversion process. For more information on the LOM port of the ADC appliance, see [Lights out management port of the NetScaler SDX appliance](#).

To convert an MPX appliance to an SDX appliance, you must access the appliance through a console cable attached to a computer or terminal. Before connecting the console cable, configure the computer or terminal to support the following configuration:

- VT100 terminal emulation
- 9600 baud
- 8 data bits
- 1 stop bit
- Parity and flow control set to NONE

Connect one end of the console cable to the RS232 serial port on the appliance, and the other end to the computer or terminal.

Note:

To use a cable with an RJ-45 converter, insert the optional converter into the console port and

attach the cable to it.

With the cable attached, verify that the MPX appliance's components are functioning correctly. You are then ready to begin the conversion. The conversion process modifies the BIOS, installs a Citrix Hypervisor and a Service Virtual Machine image, and copies the NetScaler VPX image to the Solid State Drive.

The conversion process also sets up a redundant array of independent disks (RAID) controller for local storage and NetScaler VPX storage. SSD slots #1 and #2 are used for local storage and SSD slots #3, #4, #5, #6, #7, and #8 are used for NetScaler VPX storage.

After the conversion process, modify the appliance's configuration and apply a new license. You can then provision the VPX instances through the Management Service on what is now an NetScaler SDX appliance.

Verify proper operation of the MPX appliance's components

1. Access the console port and enter the administrator credentials.
2. Run the following command from the command line interface of the appliance to display the serial number: `show hardware`. You might need the serial number to log on to the appliance after the conversion.

Example

```
1 > show hardware
2 Platform: NSMPX-26000-50S 28*CPU+256GB+4*MLX(50)+16*F2X+2*E1K+4*4-
  CHIP CO 520310
3 Manufactured on: 9/15/2020
4 CPU: 2400MHZ
5 Host Id: 1862303878
6 Serial no: 83WRVD62EM
7 Encoded serial no: 83WRVD62EM
8 Netscaler UUID: 258f9971-f7db-11ea-b021-00e0ed9041b6
9 BMC Revision: 5.03
10 Done
```

The serial number might be helpful when you want to contact Citrix technical support.

3. Run the following command to display the status of the active interfaces:

`show interface`

Example

```
1 > show interface
2
3 1) Interface 0/1 (Gig Ethernet 10/100/1000 Mbits) #8
4 flags=0xc020 <ENABLED, UP, UP, autoneg, HAMON, HEARTBEAT, 802.1q>
```

```
5 MTU=1500, native vlan=1, MAC=0c:c4:7a:56:64:7e, uptime 120h29m33s
6 Requested: media AUTO, speed AUTO, duplex AUTO, fctl OFF,
7 throughput 0
8 Actual: media UTP, speed 1000, duplex FULL, fctl OFF, throughput
9 1000
10 LLDP Mode: NONE, LR Priority: 1024
11 RX: Pkts(1614945) Bytes(104805024) Errs(0) Drops(1601312) Stalls
12 (0)
13 TX: Pkts(9166) Bytes(2556380) Errs(0) Drops(0) Stalls(0)
14 NIC: InDisc(0) OutDisc(0) Fctls(0) Stalls(0) Hangs(0) Muted(0)
15 Bandwidth thresholds are not set.
16 2) Interface 0/2 (Gig Ethernet 10/100/1000 Mbits) #9
17 flags=0x4000 <ENABLED, DOWN, down, autoneg, HAMON, HEARTBEAT,
18 802.1q>
19 MTU=1500, native vlan=1, MAC=0c:c4:7a:56:64:7f, downtime 120
20 h29m53s
21 Requested: media AUTO, speed AUTO, duplex AUTO, fctl OFF,
22 throughput 0
23 LLDP Mode: NONE, LR Priority: 1024
24 RX: Pkts(0) Bytes(0) Errs(0) Drops(0) Stalls(0)
25 TX: Pkts(0) Bytes(0) Errs(0) Drops(0) Stalls(0)
26 NIC: InDisc(0) OutDisc(0) Fctls(0) Stalls(0) Hangs(0) Muted(0)
27 Bandwidth thresholds are not set.
28 3) Interface 25/1 (25G Ethernet, unknown device) #10
29 flags=0x4000 <ENABLED, DOWN, down, autoneg, HAMON, HEARTBEAT,
30 802.1q>
31 MTU=1500, native vlan=1, MAC=00:e0:ed:90:41:bc, downtime 120
32 h29m53s
33 Requested: media AUTO, speed AUTO, duplex AUTO, fctl OFF,
34 throughput 0
35 LLDP Mode: NONE, LR Priority: 1024
36 RX: Pkts(0) Bytes(0) Errs(0) Drops(0) Stalls(0)
37 TX: Pkts(0) Bytes(0) Errs(0) Drops(0) Stalls(0)
38 NIC: InDisc(0) OutDisc(0) Fctls(0) Stalls(0) Hangs(0) Muted(0)
39 Bandwidth thresholds are not set.
40 Rx Ring: Configured size=2048, Actual size=512, Type: Elastic
41 4) Interface 25/2 (25G Ethernet, unknown device) #11
42 flags=0x4000 <ENABLED, DOWN, down, autoneg, HAMON, HEARTBEAT,
43 802.1q>
44 MTU=1500, native vlan=1, MAC=00:e0:ed:90:41:bd, downtime 120
45 h29m53s
46 Requested: media AUTO, speed AUTO, duplex AUTO, fctl OFF,
47 throughput 0
48 LLDP Mode: NONE, LR Priority: 1024
49 RX: Pkts(0) Bytes(0) Errs(0) Drops(0) Stalls(0)
50 TX: Pkts(0) Bytes(0) Errs(0) Drops(0) Stalls(0)
```

```
50 NIC: InDisc(0) OutDisc(0) Fctls(0) Stalls(0) Hangs(0) Muted(0)
51 Bandwidth thresholds are not set.
52 Rx Ring: Configured size=2048, Actual size=512, Type: Elastic
53
54 5) Interface 25/3 (25G Ethernet, unknown device) #12
55 flags=0x4000 <ENABLED, DOWN, down, autoneg, HAMON, HEARTBEAT,
    802.1q>
56 MTU=1500, native vlan=1, MAC=00:e0:ed:90:41:be, downtime 120
    h29m53s
57 Requested: media AUTO, speed AUTO, duplex AUTO, fctl OFF,
58             throughput 0
59 LLDP Mode: NONE,                LR Priority: 1024
60
61 RX: Pkts(0) Bytes(0) Errs(0) Drops(0) Stalls(0)
62 TX: Pkts(0) Bytes(0) Errs(0) Drops(0) Stalls(0)
63 NIC: InDisc(0) OutDisc(0) Fctls(0) Stalls(0) Hangs(0) Muted(0)
64 Bandwidth thresholds are not set.
65 Rx Ring: Configured size=2048, Actual size=512, Type: Elastic
66
67 6) Interface 25/4 (25G Ethernet, unknown device) #13
68 flags=0x4000 <ENABLED, DOWN, down, autoneg, HAMON, HEARTBEAT,
    802.1q>
69 MTU=1500, native vlan=1, MAC=00:e0:ed:90:41:bf, downtime 120
    h29m53s
70 Requested: media AUTO, speed AUTO, duplex AUTO, fctl OFF,
71             throughput 0
72 LLDP Mode: NONE,                LR Priority: 1024
73
74 RX: Pkts(0) Bytes(0) Errs(0) Drops(0) Stalls(0)
75 TX: Pkts(0) Bytes(0) Errs(0) Drops(0) Stalls(0)
76 NIC: InDisc(0) OutDisc(0) Fctls(0) Stalls(0) Hangs(0) Muted(0)
77 Bandwidth thresholds are not set.
78 Rx Ring: Configured size=2048, Actual size=512, Type: Elastic
79
80 7) Interface 25/5 (25G Ethernet, unknown device) #14
81 flags=0x4000 <ENABLED, DOWN, down, autoneg, HAMON, HEARTBEAT,
    802.1q>
82 MTU=1500, native vlan=1, MAC=00:e0:ed:90:41:f2, downtime 120
    h29m53s
83 Requested: media AUTO, speed AUTO, duplex AUTO, fctl OFF,
84             throughput 0
85 LLDP Mode: NONE,                LR Priority: 1024
86
87 RX: Pkts(0) Bytes(0) Errs(0) Drops(0) Stalls(0)
88 TX: Pkts(0) Bytes(0) Errs(0) Drops(0) Stalls(0)
89 NIC: InDisc(0) OutDisc(0) Fctls(0) Stalls(0) Hangs(0) Muted(0)
90 Bandwidth thresholds are not set.
91 Rx Ring: Configured size=2048, Actual size=512, Type: Elastic
92
93 8) Interface 25/6 (25G Ethernet, unknown device) #15
94 flags=0x4000 <ENABLED, DOWN, down, autoneg, HAMON, HEARTBEAT,
    802.1q>
95 MTU=1500, native vlan=1, MAC=00:e0:ed:90:41:f3, downtime 120
```

```
h29m53s
96 Requested: media AUTO, speed AUTO, duplex AUTO, fctl OFF,
97     throughput 0
98 LLDP Mode: NONE,           LR Priority: 1024
99
100 RX: Pkts(0) Bytes(0) Errs(0) Drops(0) Stalls(0)
101 TX: Pkts(0) Bytes(0) Errs(0) Drops(0) Stalls(0)
102 NIC: InDisc(0) OutDisc(0) Fctls(0) Stalls(0) Hangs(0) Muted(0)
103 Bandwidth thresholds are not set.
104 Rx Ring: Configured size=2048, Actual size=512, Type: Elastic
105
106 9) Interface 25/7 (25G Ethernet, unknown device) #16
107 flags=0x4000 <ENABLED, DOWN, down, autoneg, HAMON, HEARTBEAT,
108     802.1q>
109 MTU=1500, native vlan=1, MAC=00:e0:ed:90:41:f4, downtime 120
110 h29m53s
111 Requested: media AUTO, speed AUTO, duplex AUTO, fctl OFF,
112     throughput 0
113 LLDP Mode: NONE,           LR Priority: 1024
114
115 RX: Pkts(0) Bytes(0) Errs(0) Drops(0) Stalls(0)
116 TX: Pkts(0) Bytes(0) Errs(0) Drops(0) Stalls(0)
117 NIC: InDisc(0) OutDisc(0) Fctls(0) Stalls(0) Hangs(0) Muted(0)
118 Bandwidth thresholds are not set.
119 Rx Ring: Configured size=2048, Actual size=512, Type: Elastic
120
121 10) Interface 25/8 (25G Ethernet, unknown device) #17
122 flags=0x4000 <ENABLED, DOWN, down, autoneg, HAMON, HEARTBEAT,
123     802.1q>
124 MTU=1500, native vlan=1, MAC=00:e0:ed:90:41:f5, downtime 120
125 h30m00s
126 Requested: media AUTO, speed AUTO, duplex AUTO, fctl OFF,
127     throughput 0
128 LLDP Mode: NONE,           LR Priority: 1024
129
130 RX: Pkts(0) Bytes(0) Errs(0) Drops(0) Stalls(0)
131 TX: Pkts(0) Bytes(0) Errs(0) Drops(0) Stalls(0)
132 NIC: InDisc(0) OutDisc(0) Fctls(0) Stalls(0) Hangs(0) Muted(0)
133 Bandwidth thresholds are not set.
134 Rx Ring: Configured size=2048, Actual size=512, Type: Elastic
135
136 11) Interface 25/9 (25G Ethernet, unknown device) #2
137 flags=0x4000 <ENABLED, DOWN, down, autoneg, HAMON, HEARTBEAT,
138     802.1q>
139 MTU=1500, native vlan=1, MAC=00:e0:ed:90:41:b4, downtime 120
140 h30m00s
141 Requested: media AUTO, speed AUTO, duplex AUTO, fctl OFF,
142     throughput 0
143 LLDP Mode: NONE,           LR Priority: 1024
144
145 RX: Pkts(0) Bytes(0) Errs(0) Drops(0) Stalls(0)
146 TX: Pkts(0) Bytes(0) Errs(0) Drops(0) Stalls(0)
147 NIC: InDisc(0) OutDisc(0) Fctls(0) Stalls(0) Hangs(0) Muted(0)
```

```
142 Bandwidth thresholds are not set.
143 Rx Ring: Configured size=2048, Actual size=512, Type: Elastic
144
145 12) Interface 25/10 (25G Ethernet, unknown device) #3
146 flags=0x4000 <ENABLED, DOWN, down, autoneg, HAMON, HEARTBEAT,
    802.1q>
147 MTU=1500, native vlan=1, MAC=00:e0:ed:90:41:b5, downtime 120
    h30m00s
148 Requested: media AUTO, speed AUTO, duplex AUTO, fctl OFF,
149           throughput 0
150 LLDP Mode: NONE,           LR Priority: 1024
151
152 RX: Pkts(0) Bytes(0) Errs(0) Drops(0) Stalls(0)
153 TX: Pkts(0) Bytes(0) Errs(0) Drops(0) Stalls(0)
154 NIC: InDisc(0) OutDisc(0) Fctls(0) Stalls(0) Hangs(0) Muted(0)
155 Bandwidth thresholds are not set.
156 Rx Ring: Configured size=2048, Actual size=512, Type: Elastic
157
158 13) Interface 25/11 (25G Ethernet, unknown device) #0
159 flags=0x4000 <ENABLED, DOWN, down, autoneg, HAMON, HEARTBEAT,
    802.1q>
160 MTU=1500, native vlan=1, MAC=00:e0:ed:90:41:b6, downtime 120
    h30m00s
161 Requested: media AUTO, speed AUTO, duplex AUTO, fctl OFF,
162           throughput 0
163 LLDP Mode: NONE,           LR Priority: 1024
164
165 RX: Pkts(0) Bytes(0) Errs(0) Drops(0) Stalls(0)
166 TX: Pkts(0) Bytes(0) Errs(0) Drops(0) Stalls(0)
167 NIC: InDisc(0) OutDisc(0) Fctls(0) Stalls(0) Hangs(0) Muted(0)
168 Bandwidth thresholds are not set.
169 Rx Ring: Configured size=2048, Actual size=512, Type: Elastic
170
171 14) Interface 25/12 (25G Ethernet, unknown device) #1
172 flags=0x4000 <ENABLED, DOWN, down, autoneg, HAMON, HEARTBEAT,
    802.1q>
173 MTU=1500, native vlan=1, MAC=00:e0:ed:90:41:b7, downtime 120
    h30m00s
174 Requested: media AUTO, speed AUTO, duplex AUTO, fctl OFF,
175           throughput 0
176 LLDP Mode: NONE,           LR Priority: 1024
177
178 RX: Pkts(0) Bytes(0) Errs(0) Drops(0) Stalls(0)
179 TX: Pkts(0) Bytes(0) Errs(0) Drops(0) Stalls(0)
180 NIC: InDisc(0) OutDisc(0) Fctls(0) Stalls(0) Hangs(0) Muted(0)
181 Bandwidth thresholds are not set.
182 Rx Ring: Configured size=2048, Actual size=512, Type: Elastic
183
184 15) Interface 25/13 (25G Ethernet, unknown device) #6
185 flags=0x4000 <ENABLED, DOWN, down, autoneg, HAMON, HEARTBEAT,
    802.1q>
186 MTU=1500, native vlan=1, MAC=00:e0:ed:90:41:ee, downtime 120
    h30m00s
```

```
187 Requested: media AUTO, speed AUTO, duplex AUTO, fctl OFF,
188     throughput 0
189 LLDP Mode: NONE,           LR Priority: 1024
190
191 RX: Pkts(0) Bytes(0) Errs(0) Drops(0) Stalls(0)
192 TX: Pkts(0) Bytes(0) Errs(0) Drops(0) Stalls(0)
193 NIC: InDisc(0) OutDisc(0) Fctls(0) Stalls(0) Hangs(0) Muted(0)
194 Bandwidth thresholds are not set.
195 Rx Ring: Configured size=2048, Actual size=512, Type: Elastic
196
197 16) Interface 25/14 (25G Ethernet, unknown device) #7
198 flags=0x4000 <ENABLED, DOWN, down, autoneg, HAMON, HEARTBEAT,
199     802.1q>
200 MTU=1500, native vlan=1, MAC=00:e0:ed:90:41:ef, downtime 120
201     h30m00s
202 Requested: media AUTO, speed AUTO, duplex AUTO, fctl OFF,
203     throughput 0
204 LLDP Mode: NONE,           LR Priority: 1024
205
206 RX: Pkts(0) Bytes(0) Errs(0) Drops(0) Stalls(0)
207 TX: Pkts(0) Bytes(0) Errs(0) Drops(0) Stalls(0)
208 NIC: InDisc(0) OutDisc(0) Fctls(0) Stalls(0) Hangs(0) Muted(0)
209 Bandwidth thresholds are not set.
210 Rx Ring: Configured size=2048, Actual size=512, Type: Elastic
211
212 17) Interface 25/15 (25G Ethernet, unknown device) #4
213 flags=0x4000 <ENABLED, DOWN, down, autoneg, HAMON, HEARTBEAT,
214     802.1q>
215 MTU=1500, native vlan=1, MAC=00:e0:ed:90:41:f0, downtime 120
216     h30m00s
217 Requested: media AUTO, speed AUTO, duplex AUTO, fctl OFF,
218     throughput 0
219 LLDP Mode: NONE,           LR Priority: 1024
220
221 RX: Pkts(0) Bytes(0) Errs(0) Drops(0) Stalls(0)
222 TX: Pkts(0) Bytes(0) Errs(0) Drops(0) Stalls(0)
223 NIC: InDisc(0) OutDisc(0) Fctls(0) Stalls(0) Hangs(0) Muted(0)
224 Bandwidth thresholds are not set.
225 Rx Ring: Configured size=2048, Actual size=512, Type: Elastic
226
227 18) Interface 25/16 (25G Ethernet, unknown device) #5
228 flags=0x4000 <ENABLED, DOWN, down, autoneg, HAMON, HEARTBEAT,
229     802.1q>
230 MTU=1500, native vlan=1, MAC=00:e0:ed:90:41:f1, downtime 120
231     h30m00s
232 Requested: media AUTO, speed AUTO, duplex AUTO, fctl OFF,
233     throughput 0
234 LLDP Mode: NONE,           LR Priority: 1024
235
236 RX: Pkts(0) Bytes(0) Errs(0) Drops(0) Stalls(0)
237 TX: Pkts(0) Bytes(0) Errs(0) Drops(0) Stalls(0)
238 NIC: InDisc(0) OutDisc(0) Fctls(0) Stalls(0) Hangs(0) Muted(0)
239 Bandwidth thresholds are not set.
```

```
234 Rx Ring: Configured size=2048, Actual size=512, Type: Elastic
235
236 19) Interface 50/1 (mce Ethernet, unknown device) #20
237 flags=0xc020 <ENABLED, UP, UP, autoneg, HAMON, HEARTBEAT, 802.1q>
238 MTU=9216, native vlan=1, MAC=24:8a:07:a4:91:0c, uptime 99h59m54s
239 Requested: media AUTO, speed AUTO, duplex AUTO, fctl OFF,
240 throughput 0
241 Actual: media UTP, speed 50000, duplex FULL, fctl OFF, throughput
242 50000
243 LLDLP Mode: NONE, LR Priority: 1024
244
244 RX: Pkts(215681) Bytes(11431096) Errs(0) Drops(215680) Stalls(0)
245 TX: Pkts(131) Bytes(5516) Errs(0) Drops(0) Stalls(0)
246 NIC: InDisc(0) OutDisc(0) Fctls(0) Stalls(0) Hangs(0) Muted(0)
247 Bandwidth thresholds are not set.
248
249 20) Interface 50/2 (mce Ethernet, unknown device) #21
250 flags=0xc020 <ENABLED, UP, UP, autoneg, HAMON, HEARTBEAT, 802.1q>
251 MTU=1500, native vlan=1, MAC=24:8a:07:a4:91:0d, uptime 100h00m22s
252 Requested: media AUTO, speed AUTO, duplex AUTO, fctl OFF,
253 throughput 0
254 Actual: media UTP, speed 50000, duplex FULL, fctl OFF, throughput
255 50000
256 LLDLP Mode: NONE, LR Priority: 1024
257
257 RX: Pkts(313720) Bytes(17365302) Errs(0) Drops(312232) Stalls(0)
258 TX: Pkts(114) Bytes(4788) Errs(0) Drops(0) Stalls(0)
259 NIC: InDisc(0) OutDisc(0) Fctls(0) Stalls(0) Hangs(0) Muted(0)
260 Bandwidth thresholds are not set.
261
262 21) Interface 50/3 (100G Ethernet) #18
263 flags=0x4000 <ENABLED, DOWN, down, autoneg, HAMON, HEARTBEAT,
264 802.1q>
264 MTU=1500, native vlan=1, MAC=24:8a:07:a4:91:00, downtime 120
265 h30m07s
266 Requested: media AUTO, speed AUTO, duplex AUTO, fctl OFF,
267 throughput 0
268 LLDLP Mode: NONE, LR Priority: 1024
269
269 RX: Pkts(0) Bytes(0) Errs(0) Drops(0) Stalls(0)
270 TX: Pkts(0) Bytes(0) Errs(0) Drops(0) Stalls(0)
271 NIC: InDisc(0) OutDisc(0) Fctls(0) Stalls(0) Hangs(0) Muted(0)
272 Bandwidth thresholds are not set.
273
274 22) Interface 50/4 (100G Ethernet) #19
275 flags=0x4000 <ENABLED, DOWN, down, autoneg, HAMON, HEARTBEAT,
276 802.1q>
276 MTU=1500, native vlan=1, MAC=24:8a:07:a4:91:01, downtime 120
277 h30m07s
278 Requested: media AUTO, speed AUTO, duplex AUTO, fctl OFF,
279 throughput 0
280 LLDLP Mode: NONE, LR Priority: 1024
```

```

281 RX: Pkts(0) Bytes(0) Errs(0) Drops(0) Stalls(0)
282 TX: Pkts(0) Bytes(0) Errs(0) Drops(0) Stalls(0)
283 NIC: InDisc(0) OutDisc(0) Fctls(0) Stalls(0) Hangs(0) Muted(0)
284 Bandwidth thresholds are not set.
285
286 23)      Interface L0/1 (Netscaler Loopback interface) #22
287         flags=0x20008020 <ENABLED, UP, UP>
288 MTU=9216, native vlan=1, MAC=0c:c4:7a:56:64:7e, uptime 120h30m01s
289 LLDP Mode: NONE,          LR Priority: 1024
290
291 RX: Pkts(611167959) Bytes(89143315781) Errs(0) Drops(0) Stalls(0)
292 TX: Pkts(1207140213) Bytes(120806672260) Errs(0) Drops(0) Stalls
    (0)
293 Bandwidth thresholds are not set.
294
295 Done
296 >

```

4. In the `show interface` command's output, verify that all the interfaces are enabled and the status of every interface is shown as UP/UP.

Notes:

- The interface status is displayed as UP/UP only if the cables are connected to the interfaces.
- If you do not have an SFP+ transceiver for every port, verify the interfaces in stages. After checking the first set of interfaces, unplug the SFP+ transceivers and plug them in to the next set of ports.

5. Run the following command for each of the interfaces that are not in the UP/UP state: `enable interface 50/x` Where x is the new interface number.

```

1 > enable interface 50/1
2 Done
3 > enable interface 50/2
4 Done
5 > enable interface 50/3
6 Done
7 > enable interface 50/4
8 Done

```

6. Run the following command to verify that the status of the power supplies is normal:

```
stat system -detail
```

Example

```

1 > stat system -detail
2
3 Citrix ADC Executive View

```



```

4
5 System Information:
6 Up since      Wed Jan 20 21:35:18 2021
7 Up since(Local) Wed Jan 20 21:35:18 2021
8 Memory usage (MB)          5802
9 InUse Memory (%)           2.52
10 Number of CPUs             15
11
12 System Health Statistics (Standard):
13 CPU 0 Core Voltage (Volts)      1.80
14 CPU 1 Core Voltage (Volts)      1.80
15 Main 3.3 V Supply Voltage       3.35
16 Standby 3.3 V Supply Voltage    3.25
17 +5.0 V Supply Voltage           5.03
18 +12.0 V Supply Voltage         12.13
19 Battery Voltage (Volts)        2.98
20 Intel CPU Vtt Power(Volts)     0.00
21 5V Standby Voltage(Volts)      4.97
22 Voltage Sensor2(Volts)         0.00
23 CPU Fan 0 Speed (RPM)          3100
24 CPU Fan 1 Speed (RPM)          3100
25 System Fan Speed (RPM)         3100
26 System Fan 1 Speed (RPM)       3100
27 System Fan 2 Speed (RPM)       3100
28 CPU 0 Temperature (Celsius)    47
29 CPU 1 Temperature (Celsius)    51
30 Internal Temperature (Celsius) 35
31 Power supply 1 status          NORMAL
32 Power supply 2 status          NORMAL
33 Power supply 3 status          NOT SUPPORTED
34 Power supply 4 status          NOT SUPPORTED
35
36 System Disk Statistics:
37 /flash Size (MB)               23801
38 /flash Used (MB)                787
39 /flash Available (MB)          21110
40 /flash Used (%)                  3
41 /var Size (MB)                  341167
42 /var Used (MB)                  112391
43 /var Available (MB)             201482
44 /var Used (%)                    35
45
46 System Health Statistics(Auxiliary):
47 Voltage 0 (Volts)               1.20
48 Voltage 1 (Volts)               1.20
49 Voltage 2 (Volts)               1.21
50 Voltage 3 (Volts)               1.20
51 Voltage 4 (Volts)               1.54
52 Voltage 5 (Volts)               0.00
53 Voltage 6 (Volts)               0.00
54 Voltage 7 (Volts)               0.00
55 Fan 0 Speed (RPM)               3200
56 Fan 1 Speed (RPM)               0

```

```

57 Fan 2 Speed (RPM)                0
58 Fan 3 Speed (RPM)                0
59 Temperature 0 (Celsius)          27
60 Temperature 1 (Celsius)          38
61 Temperature 2 (Celsius)          0
62 Temperature 3 (Celsius)          0
63 Done
64 >

```

1. Run the following command to generate a tar of system configuration data and statistics:

```
show techsupport
```

Example

```

1 > show techsupport
2
3 showtechsupport data collector tool - $Revision$!
4 NetScaler version 13.0
5 The NS IP of this box is 10.217.206.43
6 This is not HA configuration
7 Copying selected configuration files ....
8 Running shell commands ....
9 Running CLI show commands ....
10 Collecting ns running configuration....
11 Collecting running gslb configuration....
12 Running CLI stat commands ....
13 Running vtysh commands ....
14 Copying newslog files ....
15 Copying core files from /var/core ....
16 Copying core files from /var/crash ....
17 Copying GSLB location database files ....
18 Copying GSLB auto sync log files ....
19 Copying Safenet Gateway log files ....
20 Copying messages, ns.log, dmesg and other log files ....
21 Creating archive ....
22 /var/tmp/support/support.tgz ---- points to ---> /var/tmp/support
   /collector_P_10.217.206.43_5Dec2020_05_32.tar.gz
23
24 showtechsupport script took 1 minute(s) and 17 second(s) to
   execute.
25 Done

```

Note

The output of the command is available in the `/var/tmp/support/collector_<IP_address>_P_<date>.tar.gz` file. Copy this file to another computer for future reference. The output of the command might be helpful when you want to contact Citrix technical support.

2. At the command line interface, switch to the shell prompt. Type: `shell`

Example

```
1 > shell
2 Copyright (c) 1992-2013 The FreeBSD Project.
3 Copyright (c) 1979, 1980, 1983, 1986, 1988, 1989, 1991, 1992,
  1993, 1994
4   The Regents of the University of California. All rights
  reserved.
5
6 root@ns#
```

3. Run the following command to verify the memory on your appliance:

```
root@ns# grep "memory"/var/nslog/dmesg.boot
```

Example

```
1 root@ns# grep "memory" /var/nslog/dmesg.boot
2 real memory = 274877906944 (262144 MB)
3 avail memory = 264024535040 (251793 MB)
4 root@ns#
```

4. Run the following command to verify the number of CPU cores depending upon your appliance:

```
root@ns# grep "cpu"/var/nslog/dmesg.boot
```

Example

```
1 root@ns# grep "cpu" /var/nslog/dmesg.boot
2 cpu0 (BSP): APIC ID: 0
3 cpu1 (AP): APIC ID: 2
4 cpu2 (AP): APIC ID: 4
5 cpu3 (AP): APIC ID: 6
6 cpu4 (AP): APIC ID: 8
7 cpu5 (AP): APIC ID: 10
8 cpu6 (AP): APIC ID: 12
9 cpu7 (AP): APIC ID: 16
10 cpu8 (AP): APIC ID: 18
11 cpu9 (AP): APIC ID: 20
12 cpu10 (AP): APIC ID: 22
13 cpu11 (AP): APIC ID: 24
14 cpu12 (AP): APIC ID: 26
15 cpu13 (AP): APIC ID: 28
16 cpu14 (AP): APIC ID: 32
17 cpu15 (AP): APIC ID: 34
18 cpu16 (AP): APIC ID: 36
19 cpu17 (AP): APIC ID: 38
20 cpu18 (AP): APIC ID: 40
21 cpu19 (AP): APIC ID: 42
22 cpu20 (AP): APIC ID: 44
23 cpu21 (AP): APIC ID: 48
24 cpu22 (AP): APIC ID: 50
25 cpu23 (AP): APIC ID: 52
26 cpu24 (AP): APIC ID: 54
27 cpu25 (AP): APIC ID: 56
```

```
28 cpu26 (AP): APIC ID: 58
29 cpu27 (AP): APIC ID: 60
30 cpu0: <ACPI CPU> on acpi0
31 cpu1: <ACPI CPU> on acpi0
32 cpu2: <ACPI CPU> on acpi0
33 cpu3: <ACPI CPU> on acpi0
34 cpu4: <ACPI CPU> on acpi0
35 cpu5: <ACPI CPU> on acpi0
36 cpu6: <ACPI CPU> on acpi0
37 cpu7: <ACPI CPU> on acpi0
38 cpu8: <ACPI CPU> on acpi0
39 cpu9: <ACPI CPU> on acpi0
40 cpu10: <ACPI CPU> on acpi0
41 cpu11: <ACPI CPU> on acpi0
42 cpu12: <ACPI CPU> on acpi0
43 cpu13: <ACPI CPU> on acpi0
44 cpu14: <ACPI CPU> on acpi0
45 cpu15: <ACPI CPU> on acpi0
46 cpu16: <ACPI CPU> on acpi0
47 cpu17: <ACPI CPU> on acpi0
48 cpu18: <ACPI CPU> on acpi0
49 cpu19: <ACPI CPU> on acpi0
50 cpu20: <ACPI CPU> on acpi0
51 cpu21: <ACPI CPU> on acpi0
52 cpu22: <ACPI CPU> on acpi0
53 cpu23: <ACPI CPU> on acpi0
54 cpu24: <ACPI CPU> on acpi0
55 cpu25: <ACPI CPU> on acpi0
56 cpu26: <ACPI CPU> on acpi0
57 cpu27: <ACPI CPU> on acpi0
58 est0: <Enhanced SpeedStep Frequency Control> on cpu0
59 p4tcc0: <CPU Frequency Thermal Control> on cpu0
60 est1: <Enhanced SpeedStep Frequency Control> on cpu1
61 p4tcc1: <CPU Frequency Thermal Control> on cpu1
62 est2: <Enhanced SpeedStep Frequency Control> on cpu2
63 p4tcc2: <CPU Frequency Thermal Control> on cpu2
64 est3: <Enhanced SpeedStep Frequency Control> on cpu3
65 p4tcc3: <CPU Frequency Thermal Control> on cpu3
66 est4: <Enhanced SpeedStep Frequency Control> on cpu4
67 p4tcc4: <CPU Frequency Thermal Control> on cpu4
68 est5: <Enhanced SpeedStep Frequency Control> on cpu5
69 p4tcc5: <CPU Frequency Thermal Control> on cpu5
70 est6: <Enhanced SpeedStep Frequency Control> on cpu6
71 p4tcc6: <CPU Frequency Thermal Control> on cpu6
72 est7: <Enhanced SpeedStep Frequency Control> on cpu7
73 p4tcc7: <CPU Frequency Thermal Control> on cpu7
74 est8: <Enhanced SpeedStep Frequency Control> on cpu8
75 p4tcc8: <CPU Frequency Thermal Control> on cpu8
76 est9: <Enhanced SpeedStep Frequency Control> on cpu9
77 p4tcc9: <CPU Frequency Thermal Control> on cpu9
78 est10: <Enhanced SpeedStep Frequency Control> on cpu10
79 p4tcc10: <CPU Frequency Thermal Control> on cpu10
80 est11: <Enhanced SpeedStep Frequency Control> on cpu11
```

```

81 p4tcc11: <CPU Frequency Thermal Control> on cpu11
82 est12: <Enhanced SpeedStep Frequency Control> on cpu12
83 p4tcc12: <CPU Frequency Thermal Control> on cpu12
84 est13: <Enhanced SpeedStep Frequency Control> on cpu13
85 p4tcc13: <CPU Frequency Thermal Control> on cpu13
86 est14: <Enhanced SpeedStep Frequency Control> on cpu14
87 p4tcc14: <CPU Frequency Thermal Control> on cpu14
88 est15: <Enhanced SpeedStep Frequency Control> on cpu15
89 p4tcc15: <CPU Frequency Thermal Control> on cpu15
90 est16: <Enhanced SpeedStep Frequency Control> on cpu16
91 p4tcc16: <CPU Frequency Thermal Control> on cpu16
92 est17: <Enhanced SpeedStep Frequency Control> on cpu17
93 p4tcc17: <CPU Frequency Thermal Control> on cpu17
94 est18: <Enhanced SpeedStep Frequency Control> on cpu18
95 p4tcc18: <CPU Frequency Thermal Control> on cpu18
96 est19: <Enhanced SpeedStep Frequency Control> on cpu19
97 p4tcc19: <CPU Frequency Thermal Control> on cpu19
98 est20: <Enhanced SpeedStep Frequency Control> on cpu20
99 p4tcc20: <CPU Frequency Thermal Control> on cpu20
100 est21: <Enhanced SpeedStep Frequency Control> on cpu21
101 p4tcc21: <CPU Frequency Thermal Control> on cpu21
102 est22: <Enhanced SpeedStep Frequency Control> on cpu22
103 p4tcc22: <CPU Frequency Thermal Control> on cpu22
104 est23: <Enhanced SpeedStep Frequency Control> on cpu23
105 p4tcc23: <CPU Frequency Thermal Control> on cpu23
106 est24: <Enhanced SpeedStep Frequency Control> on cpu24
107 p4tcc24: <CPU Frequency Thermal Control> on cpu24
108 est25: <Enhanced SpeedStep Frequency Control> on cpu25
109 p4tcc25: <CPU Frequency Thermal Control> on cpu25
110 est26: <Enhanced SpeedStep Frequency Control> on cpu26
111 p4tcc26: <CPU Frequency Thermal Control> on cpu26
112 est27: <Enhanced SpeedStep Frequency Control> on cpu27
113 p4tcc27: <CPU Frequency Thermal Control> on cpu27
114 root@ns#

```

5. Run the following command to verify that the /var drive is mounted as /dev/ ar0s1a:

```
root@ns# df -h
```

Example

```

1 root@ns# df -h
2 Filesystem      Size      Used    Avail Capacity  Mounted on
3 /dev/md0        422M      404M     9.1M    98%        /
4 devfs           1.0k      1.0k      0B     100%       /dev
5 procfs          4.0k      4.0k      0B     100%       /proc
6 /dev/ar0s1a     23G       6.9G     14G     32%       /flash
7 /dev/ar0s1e    333G       32G     274G     10%       /var
8 root@ns#

```

6. Type the following command to run the ns_hw_err.bash script, which checks for latent hardware errors:

```
root@ns# ns_hw_err.bash
```

Example

```
1 root@ns# ns_hw_err.bash
2 NetScaler NS13.0: Build 73.17.nc, Date: Nov 11 2020, 07:56:08
  (64-bit)
3 platform: serial 83WRVD62EM
4 platform: sysid 520310 - NSMPX-26000-50S 28*CPU+256GB+4*MLX(50)
  +16*F2X+2*E1K+4*4-CHIP COL 8955
5 HDD MODEL: ar0: 434992MB <Intel MatrixRAID RAID1> status: READY
6
7 Generating the list of newslog files to be processed...
8 Generating the events from newslog files...
9 Checking for HDD errors...
10 Checking for HDD SMART errors...
11 Checking for Flash errors...
12 Checking for Mega Raid Controller errors...
13 Checking for SSL errors...
14 Checking for BIOS errors...
15 Checking for SMB errors...
16 Checking for MotherBoard errors...
17 Checking for CMOS errors...
18     License year: 2021: OK
19 Checking for SFP/NIC errors...
20
21 Checking for Firmware errors...
22 Checking for License errors...
23 Checking for Undetected CPUs...
24 Checking for DIMM flaps...
25 Checking for Memory Channel errors...
26 Checking for LOM errors...
27 Checking the Power Supply Errors...
28 Checking for Hardware Clock errors...
29 Script Done.
30 root@ns#
```

Important: Physically disconnect all ports, except the LOM port, including the management port from the network.

7. At the shell prompt, switch to the ADC command line. Type: exit

Example

```
1 root@ns# exit
2 logout
3 Done
```

8. Run the following command to shut down the appliance. You are asked if you want to completely stop the ADC. Type: `shutdown -p now`

Example

```
1 > shutdown -p now
2 Are you sure you want to completely stop NetScaler (Y/N)? [N]:y
```

```
3 Done
4 > Dec 5 06:09:11 <auth.notice> ns shutdown: power-down by root:
5 Dec 5 06:09:13 <auth.emerg> ns init: Rebooting via init mechanism
6 Dec 5 06:09:13 <syslog.err> ns syslogd: exiting on signal 15
7 Dec 5 06:09:13 aslearn[1662]: before pthread_join(), task name:
  Aslearn_Packet_Loop_Task
8 Dec 5 06:09:15 aslearn[1662]: Exiting function ns_do_logging
9 Dec 5 06:09:15 aslearn[1662]: before pthread_join(), task name:
  Aslearn_WAL_Cleanup_Task
10 Dec 5 06:09:15 aslearn[1662]: before pthread_join(), task name:
  Aslearn_HA_Primary_Task
11 Dec 5 06:09:15 aslearn[1662]: 1662 exiting gracefully
12 Dec 5 06:09:18 [1672]: nsnet_tcpipconnect: connect() failed;
  returned -1 errno=61
13 qat0: qat_dev0 stopped 12 acceleration engines
14 pci4: Resetting device
15 qat1: qat_dev1 stopped 12 acceleration engines
16 pci6: Resetting device
17 qat2: qat_dev2 stopped 12 acceleration engines
18 pci132: Resetting device
19 qat3: qat_dev3 stopped 12 acceleration engines
20 pci134: Resetting device
21 Dec 5 06:09:33 init: some processes would not die; ps axl advised
22 reboot initiated by init with parent kernel
23 Waiting (max 60 seconds) for system process `vnlru' to stop...done
24 Waiting (max 60 seconds) for system process `bufdaemon' to stop...
  done
25 Waiting (max 60 seconds) for system process `syncer' to stop...
26 Syncing disks, vnodes remaining...0 0 0 done
27 All buffers synced.
28 Uptime: 1h53m18s
29 ixl_shutdown: lldp start 0
30 ixl_shutdown: lldp start 0
31 ixl_shutdown: lldp start 0
32 ixl_shutdown: lldp start 0
33 usb0: Controller shutdown
34 uhub0: at usb0, port 1, addr 1 (disconnected)
35 usb0: Controller shutdown complete
36 usb1: Controller shutdown
37 uhub1: at usb1, port 1, addr 1 (disconnected)
38 ugen1.2: <vendor 0x8087> at usb1 (disconnected)
39 uhub3: at uhub1, port 1, addr 2 (disconnected)
40 ugen1.3: <FTDI> at usb1 (disconnected)
41 uftdi0: at uhub3, port 1, addr 3 (disconnected)
42 ugen1.4: <vendor 0x1005> at usb1 (disconnected)
43 umass0: at uhub3, port 3, addr 4 (disconnected)
44 (da0:umass-sim0:0:0:0): lost device - 0 outstanding, 0 refs
45 (da0:umass-sim0:0:0:0): removing device entry
46 usb1: Controller shutdown complete
47 usb2: Controller shutdown
48 uhub2: at usb2, port 1, addr 1 (disconnected)
49 ugen2.2: <vendor 0x8087> at usb2 (disconnected)
50 uhub4: at uhub2, port 1, addr 2 (disconnected)
```

```

51 ugen2.3: <vendor 0x0557> at usb2 (disconnected)
52 uhub5: at uhub4, port 7, addr 3 (disconnected)
53 ugen2.4: <vendor 0x0557> at usb2 (disconnected)
54 ukbd0: at uhub5, port 1, addr 4 (disconnected)
55 ums0: at uhub5, port 1, addr 4 (disconnected)
56 usb2: Controller shutdown complete
57 ixl_shutdown: lldp start 0
58 ixl_shutdown: lldp start 0
59 ixl_shutdown: lldp start 0
60 ixl_shutdown: lldp start 0
61 acpi0: Powering system off

```

Upgrade the appliance

To upgrade the appliance, follow these steps:

1. Power off the ADC appliance.
2. Locate the two solid-state drives (SSDs) on the back of the appliance in slot #1 and slot #2, as shown in the following figure:

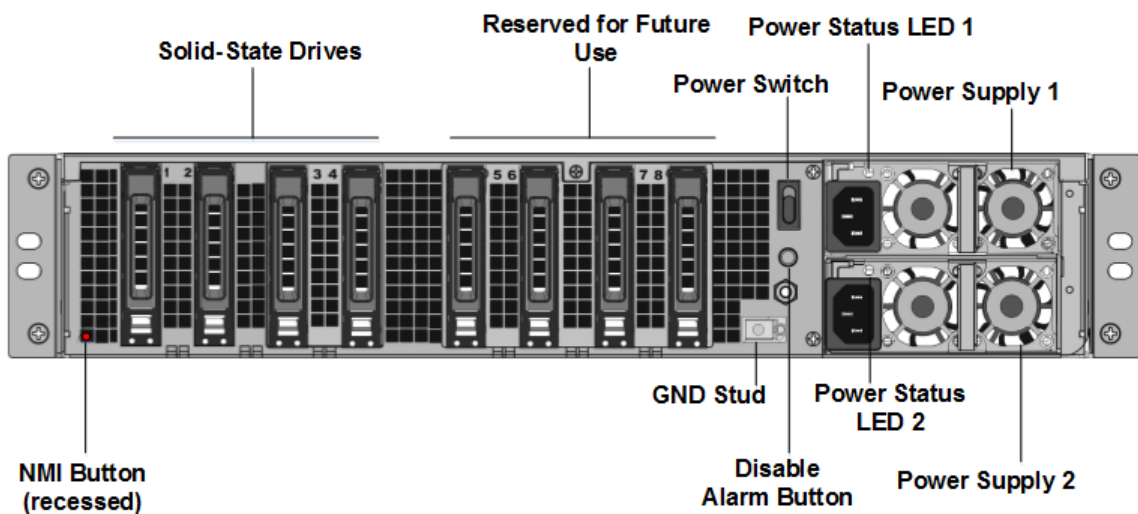

3. Verify that the replacement solid-state drives (SSDs) are the ones required for your ADC model. The conversion requires a minimum of four SSDs. The NetScaler label is on the top of one of the SSDs. The SSD is pre-populated with a new version of the BIOS and a recent build of the required NetScaler SDX Management Service. This SSD must be installed in slot # 1.
4. Remove the SSDs by pushing the safety latch of the drive cover down while pulling the drive handle.
5. On the new Citrix certified SSD drive, open the drive handle completely to the left. Then insert the new drive into the slot #1 as far as possible.

6. To seat the drive, close the handle flush with the rear side of the appliance so that the drive locks securely into the slot.

Important: The orientation of the SSD is important. When you insert the drive, make sure that the NetScaler product label is at the side, similar to the already inserted SSDs.

7. Insert a second Citrix certified SSD, which matches the capacity of the SSD in slot #1, in slot # 2.

Important

Mixing and matching of old and new SSDs is not supported. SSDs in slot #1 and slot #2, which constitute the first RAID pair (local storage), must be of the same size and type. Similarly, SSDs in slot #3 and slot #4, which constitute the second RAID pair (VPX storage), must be of the same size and type. Use only drives that are part of the provided conversion kit.

8. Insert the 960 GB blank SSD drives in slots 3, 4, 5, 6, 7, and 8.
9. Disconnect all the network cables from the data ports and the management ports.
10. Start the ADC appliance. For instructions, see [Switch on the appliance](#).

The conversion process can take up to 90 minutes, during which you must not power cycle the appliance. The entire conversion process might not be visible on the console and might appear to be unresponsive.

The conversion process updates the BIOS, installs the Citrix Hypervisor, and the Management Service Operating system.

11. Keep the console cable attached during the conversion process. Allow the process to complete, at which point the SDX login prompt appears.
12. During the conversion process the LOM port connection might be lost as it resets the IP address to the default value of 192.168.1.3.
13. The default credentials for the Citrix Hypervisor are changed to root/nsroot after the appliance is converted from an MPX to SDX. If this password does not work, try typing nsroot/the serial number of the appliance. The serial number bar code is available at the back of the appliance, and is also available in the output of the `show hardware` command.

Note:

The serial number of the appliance remains the same.

14. To make sure that the conversion is successful, verify that the FVT result indicates success. Run the following command: `tail /var/log/fvt/fvt.log`

Reconfigure the converted appliance

After the conversion process, the appliance no longer has its previous working configuration. Therefore, you can access the appliance through a web browser only by using the default IP address: 192.168.100.1/16. Configure a computer on network 192.168.0.0 and connect it directly to the appliance's management port (0/1) with a cross-over Ethernet cable. Alternately, access the NetScaler SDX appliance through a network hub by using a straight-through Ethernet cable. Use the default credentials to log on, and then do the following:

1. Select the **Dashboard** tab.
2. Verify that the **System Resource** section displays the accurate number of CPU cores, SSL cores, and the total memory for your NetScaler SDX appliance.
3. Navigate to **Configuration > System** to modify the network information of the Management Service.
4. In the **Modify Network Configuration** dialog box, specify the following details:
 - **Interface:** Management interface that connects the appliance to a management workstation or network. Possible values: 0/1, 0/2. Default: 0/1.
 - **Gateway:** IP address of the router that forwards traffic out of the appliance's subnet.
 - Select the IPv4 checkbox if you want to use the IPv4 address for the Management Service and enter the details for the following parameters:
 - **Appliance Management IP:** The IPv4 address that is used to access the Management Service by using a web browser.
 - **Netmask:** The subnet mask in which the SDX appliance is located.
 - **DNS:** IPv4 address of the primary DNS server. IPv6 addresses are not supported for the primary DNS server.
 - Select the IPv6 checkbox if you want to use the IPv6 address for the Management Service and enter the details for the following parameters:
 - **Management Service IP Address:** The IPv6 address that is used to access the Management Service by using a Web browser.
 - **Gateway IPv6 Address:** The IPv4 address of the router that forwards traffic out of the appliance's subnet.
 - Select **Additional DNS** to add DNS server IP addresses as an extra DNS server apart from the primary DNS server. The IP addresses can be either IPv4 or IPv6.

5. Click **OK**. Connection to the Management Service is lost as the network information was changed.
6. Connect the NetScaler SDX appliance’s management port 0/1 to a switch to access it through the network. Browse to the IP address used earlier and log in with the default credentials.
7. Apply the new licenses. For instructions, see [SDX Licensing Overview](#).
8. Navigate to **Configuration > System** and, in the **System Administration** group, click **Reboot Appliance**. Click **Yes** to confirm. You are now ready to provision the VPX instances on the NetScaler SDX appliance. For instructions, see [Provisioning NetScaler instances](#).

Converting a NetScaler MPX 24100 and 24150 appliance to a NetScaler SDX 24100 and 24150 appliance

December 31, 2023

You can convert a NetScaler MPX appliance to a NetScaler SDX appliance by upgrading the software through a new Solid State Drive (SSD). NetScaler supplies a field conversion kit to migrate a NetScaler MPX appliance to a NetScaler SDX appliance.

The conversion requires minimum of four SSDs.

Note

Citrix recommends that you configure the lights out management (LOM) Port of the NetScaler

appliance before starting the conversion process. For more information on the LOM port of the NetScaler appliance, see [Lights out Management Port of the NetScaler appliance](#).

To convert a NetScaler MPX appliance to a NetScaler SDX appliance, you must access the appliance through a console cable attached to a computer or terminal. Before connecting the console cable, configure the computer or terminal to support the following configuration:

- VT100 terminal emulation
- 9600 baud
- 8 data bits
- 1 stop bit
- Parity and flow control set to NONE

Connect one end of the console cable to the RS232 serial port on the appliance, and the other end to the computer or terminal.

Note

To use a cable with an RJ-45 converter, insert the optional converter into the console port and attach the cable to it.

Citrix recommends you to connect a VGA monitor to the appliance to monitor the conversion process, because the LOM connection is lost during the conversion process.

With the cable attached, verify that the MPX appliance's components are functioning correctly. You are then ready to begin the conversion. The conversion process modifies the BIOS, installs Citrix Hypervisor and a Management Service image, and copies the NetScaler VPX image to the Solid State Drive.

The conversion process also sets up a Redundant Array of Independent Disks (RAID) controller for local storage (SSD slot # 1 and SSD slot # 2) and NetScaler VPX storage (SSD slot # 3 and SSD slot # 4).

After the conversion process, modify the appliance's configuration and apply a new license. You can then provision the VPX instances through the Management Service on what is now a NetScaler SDX appliance.

To verify proper operation of the MPX appliance's components

1. Access the console port and enter the administrator credentials.
2. Run the following command from the command line interface of the appliance to display the serial number:

```
show hardware
```

The serial number might be helpful if you want to contact Citrix technical support.

3. Run the following command to display the status of the active 10G interfaces: show interface
4. In the show interface command’s output, verify that all the interfaces are enabled and the status of every interface is shown as UP/UP.

Note

If you do not have an SFP+ transceiver for every port, verify the interfaces in stages. After checking the first set of interfaces, unplug the SFP+ transceivers and plug them in to the next set of ports.

5. Run the following command for each of the interfaces that are not in the UP/UP state:

To upgrade the appliance

1. Power off the NetScaler appliance.
2. Locate two solid-state drives (SSDs) on the back of the appliance in slot #1 and slot #2, as shown in the following figure:

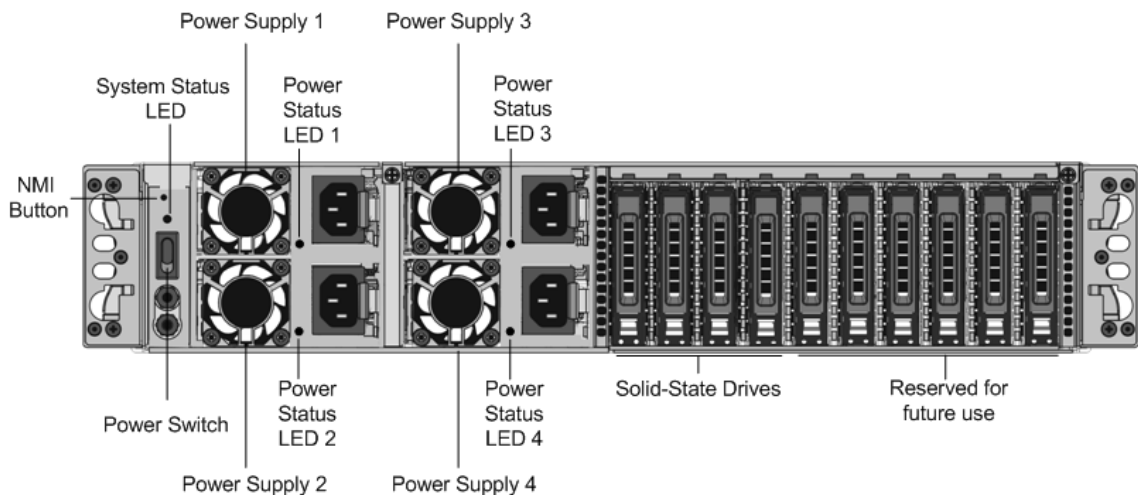

3. Verify that the replacement solid-state drives (SSDs) are the ones required for your NetScaler model. The conversion requires minimum of four SSDs. The NetScaler label is on the top of one of the solid-state drives, which is pre-populated with a new version of BIOS and a recent build of the required NetScaler SDX Management Service. This SSD must be installed in slot # 1.
4. Remove the SSDs by pushing the safety latch of the drive cover down while pulling the drive handle.
5. On the new NetScaler certified SSD drive, open the drive handle completely to the left, and then insert the new drive into the slot #1 as far as possible.

6. To seat the drive, close the handle flush with the rear side of the appliance so that the drive locks securely into the slot.

Important

The orientation of the SSD is important. When you insert the drive, make sure that the NetScaler product label is at the top.

7. Insert a second NetScaler certified SSD, which matches the capacity of the SSD in slot #1, in slot # 2. Insert more blank NetScaler certified SSDs in slots #3 and #4.

Important

Mixing and matching of old and new SSDs is not supported. SSDs in slot #1 and slot # 2, which constitute the first RAID pair (local storage), must be of the same size and type. Similarly, SSDs in slot # 3 and slot #4, which constitute the second RAID pair (VPX storage), must be of the same size and type. Only use drives that are part of the provided conversion kit.

8. Disconnect all network cables from the data ports and the management ports.
9. Start the NetScaler appliance. For instructions, see “Switching on the Appliance” in Installing the Hardware. The conversion process can run for approximately 30 minutes, during which you must not power cycle the appliance. The entire conversion process might not be visible on the console and might appear to be unresponsive. The conversion process updates the BIOS, installs the Citrix Hypervisor and the Management Service. It also copies the NetScaler VPX image to the SSD for instance provisioning, and forms the Raid1 pair.

Note

The serial number of the appliance remains the same.

10. Keep the console cable attached during the conversion process. Allow the process to complete, at which point the netscaler-sdx login: prompt appears.
11. During the conversion process the LOM port connection might be lost as it resets the IP address to the default value of 192.168.1.3. The conversion status output is available on the VGA monitor.

Convert a NetScaler MPX 14020/14030/14040/ 14060/14080/14100 appliance to a NetScaler SDX 14020/14030/14040/ 14060/14080/14100 appliance

December 31, 2023

You can convert a NetScaler MPX appliance to a NetScaler SDX appliance by upgrading the software through a new solid-state drive (SSD). NetScaler supplies a field conversion kit to migrate a NetScaler MPX appliance to an SDX appliance.

The conversion requires minimum of four SSDs.

Note: Citrix recommends that you configure the lights out management (LOM) port of the NetScaler appliance before starting the conversion process. For more information on the LOM port of the NetScaler appliance, see [Lights out management port of the NetScaler SDX appliance](#).

To convert a NetScaler MPX appliance to an SDX appliance, you must access the appliance through a console cable attached to a computer or terminal. Before connecting the console cable, configure the computer or terminal to support the following configuration:

- VT100 terminal emulation
- 9600 baud
- 8 data bits
- 1 stop bit
- Parity and flow control set to NONE

Connect one end of the console cable to the RS232 serial port on the appliance, and the other end to the computer or terminal.

Note: To use a cable with an RJ-45 converter, insert the optional converter into the console port and attach the cable to it.

Citrix recommends that you connect a VGA monitor to the appliance to monitor the conversion process, because the LOM connection might be lost during the conversion process.

With the cable attached, verify that the MPX appliance's components are functioning correctly. You are then ready to begin the conversion. The conversion process modifies the BIOS, installs the Citrix Hypervisor and a Management Service image, and copies the VPX image to the solid-state drive.

The conversion process sets up a redundant array of independent disks (RAID) controller for local storage:

- (SSD slot # 1 and SSD slot # 2)
- NetScaler VPX storage (SSD slot # 3 and SSD slot # 4)

After the conversion process, you modify the configuration of the appliance and apply a new license. You can then provision the VPX instances through the Management Service on what is now an SDX appliance.

To verify proper operation of the MPX appliance's components

1. Access the console port and enter the administrator credentials.

2. Run the following command from the command line interface of the appliance to display the serial number: `show hardware`

The serial number might be helpful in case you want to contact Citrix technical support.

Example

```
1 show hardware
2 Platform: NSMPX-14000 12*CPU+16*IX+2*E1K+2*CVM N3 250101
3 Manufactured on: 10/2/2015
4 CPU: 2600MHZ
5 Host Id: 234913926
6 Serial no: JSW4UCKKM5
7 Encoded serial no: JSW4UCKKM5
8 Done
```

3. Run the following command to display the status of the active 10G interfaces: `show interface`
4. In the `show interface` command's output, verify that all the interfaces are enabled and the status of every interface is shown as UP/UP.

Note: If you do not have an SFP+ transceiver for every port, verify the interfaces in stages. After checking the first set of interfaces, unplug the SFP+ transceivers and plug them in to the next set of ports.

5. Run the following command for each of the interfaces that are not in the UP/UP state:
`enable interface 10/x`
where x is the new interface number.
6. Run the following command to verify that the status of the power supplies is normal: `stat system -detail`
7. Run the following command to generate a tar of system configuration data and statistics: `show techsupport`

Note: The output of the command is available in the `/var/tmp/support/collector_<IP_address>_P_<date>.tar.gz` file. Copy this file to another computer for future reference. The output of the command might be helpful in case you want to contact Citrix technical support.

8. At the command line interface, switch to the shell prompt. Type: `shell`
9. Run the following command to verify the number of Cavium cards available depending upon your appliance: `root@ns# grep "cavium"/var/nslog/dmesg.boot`

Example

```
1 root@ns# grep "cavium" /var/nslog/dmesg.boot
2 Cavium cavium_probe : found card 0x177d,device=0x11
3 cavium0 mem 0xdd600000-0xdd6fffff irq 32 at device 0.0 on pci3
```



```
4 Cavium cavium_probe : found card 0x177d,device=0x11
5 cavium1 mem 0xfaa00000-0xfaafffff irq 64 at device 0.0 on pci136
```

10. Run the following command to verify the RAM memory reserved for shared memory depending upon your appliance: `root@ns# grep "memory"/var/nslog/dmesg.boot`

Example

```
1 root@ns# grep "memory" /var/nslog/dmesg.boot
2 real memory = 70866960384 (67584 MB)
3 avail memory = 66267971584 (63198 MB)
```

11. Run the following command to verify the number of CPU cores depending upon your appliance: `root@ns# grep "cpu"/var/nslog/dmesg.boot`

Example

```
1 root@ns# grep "cpu" /var/nslog/dmesg.boot
2 cpu0 (BSP): APIC ID: 0
3 cpu1 (AP): APIC ID: 2
4 cpu2 (AP): APIC ID: 4
5 cpu3 (AP): APIC ID: 6
6 cpu4 (AP): APIC ID: 8
7 cpu5 (AP): APIC ID: 10
8 cpu6 (AP): APIC ID: 32
9 cpu7 (AP): APIC ID: 34
10 cpu8 (AP): APIC ID: 36
11 cpu9 (AP): APIC ID: 38
12 cpu10 (AP): APIC ID: 40
13 cpu11 (AP): APIC ID: 42
14 cpu0: <ACPI CPU> on acpi0
15 acpi_throttle0: <ACPI CPU Throttling> on cpu0
16 cpu1: <ACPI CPU> on acpi0
17 acpi_throttle1: <ACPI CPU Throttling> on cpu1
18 cpu2: <ACPI CPU> on acpi0
19 acpi_throttle2: <ACPI CPU Throttling> on cpu2
20 cpu3: <ACPI CPU> on acpi0
21 acpi_throttle3: <ACPI CPU Throttling> on cpu3
22 cpu4: <ACPI CPU> on acpi0
23 acpi_throttle4: <ACPI CPU Throttling> on cpu4
24 cpu5: <ACPI CPU> on acpi0
25 acpi_throttle5: <ACPI CPU Throttling> on cpu5
26 cpu6: <ACPI CPU> on acpi0
27 acpi_throttle6: <ACPI CPU Throttling> on cpu6
28 cpu7: <ACPI CPU> on acpi0
29 acpi_throttle7: <ACPI CPU Throttling> on cpu7
30 cpu8: <ACPI CPU> on acpi0
31 acpi_throttle8: <ACPI CPU Throttling> on cpu8
32 cpu9: <ACPI CPU> on acpi0
33 acpi_throttle9: <ACPI CPU Throttling> on cpu9
34 cpu10: <ACPI CPU> on acpi0
35 acpi_throttle10: <ACPI CPU Throttling> on cpu10
36 cpu11: <ACPI CPU> on acpi0
```

```
37 acpi_throttle11: &lt;ACPI CPU Throttling&gt; on cpu11
38 root@ns#
```

12. Run the following command to verify that the /var drive is mounted as /dev/ad8s1e: `root@ns# df -h`
13. Run the `ns_hw_err.bash` script, which checks for latent hardware errors: `root@ns# ns_hw_err.bash`

Example

```
1 root@ns# ns_hw_err.bash
2 NetScaler NS10.1: Build 133.11.nc, Date: Sep 21 2015, 17:59:51
3 platform: serial JSW4UCKKM5
4 platform: sysid 250101 - NSMPX-14000 12*CPU+16*IX+2*E1K+2*CVM N3
5 HDD MODEL: ar0: 227328MB &lt;Intel MatrixRAID RAID1&gt; status:
  READY
6 Generating the list of newslog files to be processed...
7 Generating the events from newslog files...
8 Checking for HDD errors...
9 Checking for HDD SMART errors...
10 Checking for Flash errors...
11 /var/nslog/dmesg.prev:* DEVELOPER mode - run NetScaler manually!
12 *****
13 FOUND          1 Flash errors: DEVELOPER mode - run NetScaler
  manually
14 *****
15 Checking for SSL errors...
16 Checking for BIOS errors...
17 Checking for SMB errors...
18 Checking for MotherBoard errors...
19 Checking for CMOS errors...
20         License year: 2015: OK
21 License server failed at startup. Check /var/log/license.log
22 Vendor daemon failed at startup. Check /var/log/license.log
23 Checking for SFP/NIC errors...
24 Checking for Firmware errors...
25 Checking for License errors...
26 Checking for Undetected CPUs...
27 Checking for DIMM flaps...
28 Checking for LOM errors...
29 Checking the Power Supply Errors...
30 root@ns#
```

14. Important: Physically disconnect all ports except the LOM port, including the management port, from the network.
15. At the shell prompt, switch to the NetScaler command line. Type: `exit`
16. Run the following command to shut down the appliance: `shutdown -p now`

To upgrade the appliance

1. Power off the NetScaler appliance.
2. Locate two solid-state drives (SSDs) on the back of the appliance in slot #1 and slot #2, as shown in the following figure:

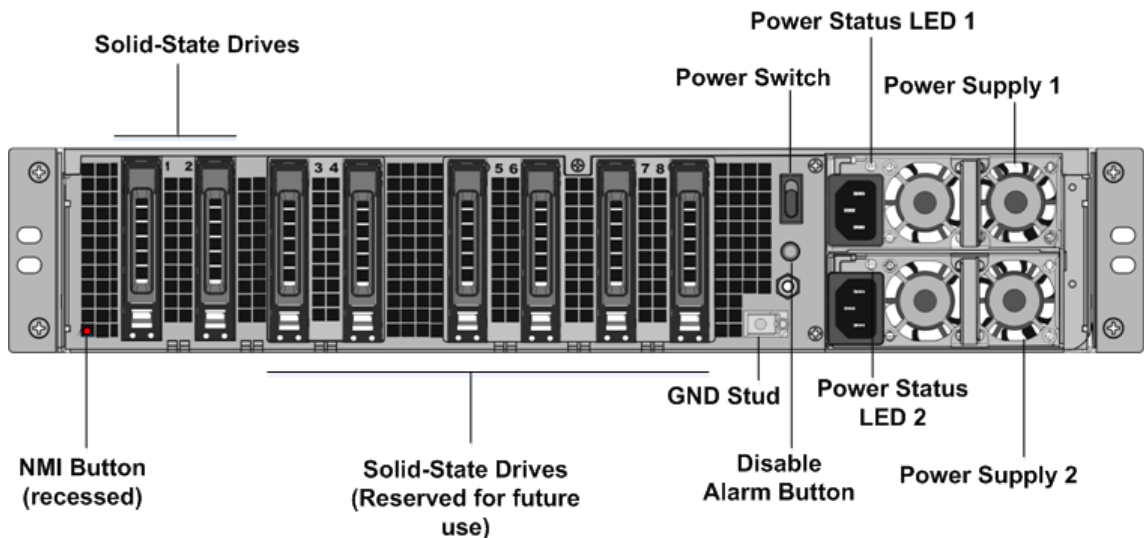

3. Verify that the replacement SSDs are the ones required for your NetScaler model. The conversion requires minimum of four SSDs. The NetScaler label is on the top of one of the SSDs. The SSD is pre-populated with a new version of the BIOS and a recent build of the Management Service. This SSD must be installed in slot # 1.
4. Remove the SSDs by pushing the safety latch of the drive cover down while pulling the drive handle.
5. On the new NetScaler certified SSD drive, open the drive handle completely to the left. Then insert the new drive into the slot #1 as far as possible.
6. To seat the drive, close the handle flush with the rear side of the appliance so that the drive locks securely into the slot.

Important: The orientation of the SSD is important. When you insert the drive, make sure that the NetScaler product label is at the top.

7. Insert a second NetScaler certified SSD, which matches the capacity of the SSD in slot #1, in slot # 2. Insert other blank NetScaler certified SSDs in slots #3 and #4.

Note: If the license of your appliance is 14040, insert other blank NetScaler certified SSDs in slots #3, #4, #5, and #6.

If the license of your appliance is 14060/14080/14100, insert other blank NetScaler certified SSDs in slots #3, #4, #5, #6, #7, and #8.

Important: Mixing and matching of old and new SSDs is not supported. SSDs in slot #1 and slot # 2, which constitute the first RAID pair (local storage), must be of the same size and type. Similarly, SSDs in slot # 3 and slot # 4, which constitute the second RAID pair (VPX storage), must be of the same size and type. Only use drives that are part of the provided conversion kit.

8. Store the old SSDs for future handling.
9. Disconnect all network cables from the data ports and the management ports.
10. Start the NetScaler appliance. For instructions, see “Switching on the Appliance” in [Installing the hardware](#).

The conversion process can run for approximately 30 minutes, during which you must not power cycle the appliance. The entire conversion process might not be visible on the console and might appear to be unresponsive.

The conversion process updates the BIOS, installs the Citrix Hypervisor and the Management Service. It also copies the VPX image to the SSD for instance provisioning, and forms the Raid1 pair.

Note: The serial number of the appliance remains the same.

11. Keep the console cable attached during the conversion process. Allow the process to complete, at which point the netscaler-sdx login: prompt appears.
12. During the conversion process the LOM port connection might be lost as it resets the IP address to the default value of 192.168.1.3. The conversion status output is available on the VGA monitor.
13. To make sure that the conversion is successful, verify that the FVT result indicates success. Run the following command: `tail /var/log/fvt/fvt.log`

Example

```
1 [root@netscaler-sdx ~]# tail /var/log/fvt/fvt.log
2 Wed, 28 Oct 2015 04:40:47 /opt/xensource/packages/files/fvt/workers/
  check_vf_count --pf_device="0000:89:00.1" --vf_count="
  40";
3 Wed, 28 Oct 2015 04:40:47 => PASS
4 Wed, 28 Oct 2015 04:40:47 /opt/xensource/packages/files/fvt/workers/
  check_vf_count --pf_device="0000:03:00.0" --vf_count="
  8";
5 Wed, 28 Oct 2015 04:40:47 => PASS
6 Wed, 28 Oct 2015 04:40:47 /opt/xensource/packages/files/fvt/workers/
  check_vf_count --pf_device="0000:88:00.0" --vf_count="
  8";
7 Wed, 28 Oct 2015 04:40:47 => PASS
8 Wed, 28 Oct 2015 04:40:47 FVT RESULT: SUCCESS!<br />
9 [root@netscaler-sdx ~]#
```

To reconfigure the converted appliance

After the conversion process, the appliance no longer has its previous working configuration. Therefore, you can access the appliance through a web browser only by using the default IP address: 192.168.100.1/16. Configure a computer on network 192.168.0.0 and connect it directly to the appliance's management port (0/1) with a cross-over Ethernet cable. Alternately, access the SDX appliance through a network hub by using a straight through Ethernet cable. Use the default credentials to log on, and then do the following:

1. Select the **Configuration** tab.
2. Verify that the System Resource section displays the accurate number of CPU cores, SSL cores, and the total memory for your SDX appliance.
3. Select the **System** node and, under **Set Up Appliance**, click **Network Configuration** to modify the IP address of the Management Service.
4. In the **Configure Network Configuration** dialog box, specify the following details:
 - Interface*—The interface through which clients connect to the Management Service. Possible values: 0/1, 0/2. Default: 0/1.
 - Citrix Hypervisor IP Address*—The IP address of Citrix Hypervisor.
 - Management Service IP Address*—The IP address of the Management Service.
 - Netmask*—The subnet mask for the subnet in which the SDX appliance is located.
 - Gateway*—The default gateway for the network.
 - DNS Server—The IP address of the DNS server.

*A mandatory parameter

5. Click OK. Connection to the Management Service is lost as the network information was changed.
6. Connect the SDX appliance's management port 0/1 to a switch to access it through the network. Browse to the IP address used earlier and log on with the default credentials.
7. Apply the new licenses. For instructions, see [SDX Licensing Overview](#).
8. Navigate to **Configuration > System** and, in the **System Administration** group, click **Reboot Appliance**. Click **Yes** to confirm. You are now ready to provision the VPX instances on the NetScaler SDX appliance. For instructions, see [Provisioning NetScaler Instances](#).

Convert a NetScaler MPX 14020 40G, MPX 14040 40G, MPX 14060 40G, MPX 14080 40G appliance to a NetScaler SDX 14020 40G, SDX 14040 40G, SDX 14060 40G, SDX 14080 40G appliance

December 31, 2023

You can convert a NetScaler MPX appliance to a NetScaler SDX appliance by upgrading the software through a new solid-state drive (SSD). NetScaler supplies a field conversion kit to migrate a NetScaler MPX appliance to an SDX appliance.

The conversion requires minimum of four SSDs.

Note: Citrix recommends that you configure the lights out management (LOM) port of the appliance before starting the conversion process. For more information on the LOM port of the NetScaler appliance, see [Lights out management port of the NetScaler SDX appliance](#).

To convert an MPX appliance to an SDX appliance, you must access the appliance through a console cable attached to a computer or terminal. Before connecting the console cable, configure the computer or terminal to support the following configuration:

- VT100 terminal emulation
- 9600 baud
- 8 data bits
- 1 stop bit
- Parity and flow control set to NONE

Connect one end of the console cable to the RS232 serial port on the appliance, and the other end to the computer or terminal.

Note: To use a cable with an RJ-45 converter, insert the optional converter into the console port and attach the cable to it.

Citrix recommends you to connect a VGA monitor to the appliance to monitor the conversion process, because the LOM connection is lost during the conversion process.

With the cable attached, verify that the MPX appliance's components are functioning correctly. You are then ready to begin the conversion. The conversion process modifies the BIOS, installs a Citrix Hypervisor and a Service Virtual Machine image, and copies the NetScaler VPX image to the Solid State Drive.

The conversion process also sets up a redundant array of independent disks (RAID) controller for local storage (SSD slot # 1 and SSD slot # 2) and NetScaler VPX storage (SSD slot # 3 and SSD slot # 4).

After the conversion process, make modifications to the appliance's configuration and apply a new license. You can then provision the VPX instances through the Management Service on what is now a

NetScaler SDX appliance.

Verify proper operation of the MPX appliance's components

1. Access the console port and enter the administrator credentials.
2. Run the following command from the command line interface of the appliance to display the serial number: show hardware

Example

```
1 show hardware
2 Platform: NSMPX-14000-40G 12*CPU+16*F1X+4*F4X+2*E1K+2*CVM N3
   250140
3 Manufactured on: 3/21/2016
4 CPU: 2600MHZ
5 Host Id: 234913926
6 Serial no: KZCHGCN810
7 Encoded serial no: KZCHGCN810
8 Done
```

The serial number might be helpful when you want to contact Citrix technical support.

3. Run the following command to display the status of the active interfaces:

show **interface**

Example

```
1 show interface
2 1) Interface 0/1 (Gig Ethernet 10/100/1000 Mbits) #10
3 flags=0xc020 &lt;ENABLED, UP, UP, autoneg, HAMON, 802.1q&gt;
4 MTU=1500, native vlan=1, MAC=0c:c4:7a:41:ea:94, uptime 43
   h59m55s
5 Requested: media AUTO, speed AUTO, duplex AUTO, fctl OFF,
6 throughput 0
7 Actual: media UTP, speed 1000, duplex FULL, fctl OFF,
   throughput 1000
8 LLDP Mode: NONE
9 RX: Pkts(44337150) Bytes(2767558041) Errs(0) Drops(41260552)
   Stalls(0)
10 TX: Pkts(128116) Bytes(9004699) Errs(0) Drops(0) Stalls(0)
11 NIC: InDisc(0) OutDisc(0) Fctls(0) Stalls(0) Hangs(0) Muted(0)
12 Bandwidth thresholds are not set.
13 2) Interface 0/2 (Gig Ethernet 10/100/1000 Mbits) #11
14 flags=0x4000 &lt;ENABLED, DOWN, down, autoneg, HAMON, 802.1q&gt;
   ;
15 MTU=1500, native vlan=1, MAC=0c:c4:7a:41:ea:95, downtime 44
   h00m08s
16 Requested: media AUTO, speed AUTO, duplex AUTO, fctl OFF,
17 throughput 0
18 LLDP Mode: NONE
```

```

19     RX: Pkts(0) Bytes(0) Errs(0) Drops(0) Stalls(0)
20     TX: Pkts(0) Bytes(0) Errs(0) Drops(0) Stalls(0)
21     NIC: InDisc(0) OutDisc(0) Fctls(0) Stalls(0) Hangs(0) Muted(0)
22     Bandwidth thresholds are not set.
23 3)   Interface 10/1 (10G Ethernet) #17
24     flags=0x4000 &lt;ENABLED, DOWN, down, autoneg, HAMON, 802.1q&gt;
25     ;
26     MTU=1500, native vlan=1, MAC=68:05:ca:30:e1:40, downtime 44
27     h00m08s
28     Requested: media AUTO, speed AUTO, duplex AUTO, fctl OFF,
29     throughput 0
30     LLDP Mode: NONE
31     RX: Pkts(0) Bytes(0) Errs(0) Drops(0) Stalls(0)
32     TX: Pkts(0) Bytes(0) Errs(0) Drops(0) Stalls(0)
33     NIC: InDisc(0) OutDisc(0) Fctls(0) Stalls(0) Hangs(0) Muted(0)
34     Bandwidth thresholds are not set.
35 4)   Interface 10/2 (10G Ethernet) #18
36     flags=0x4000 &lt;ENABLED, DOWN, down, autoneg, HAMON, 802.1q&gt;
37     ;
38     MTU=1500, native vlan=1, MAC=68:05:ca:30:e1:41, downtime 44
39     h00m08s
40     Requested: media AUTO, speed AUTO, duplex AUTO, fctl OFF,
41     throughput 0
42     LLDP Mode: NONE
43     RX: Pkts(0) Bytes(0) Errs(0) Drops(0) Stalls(0)
44     TX: Pkts(0) Bytes(0) Errs(0) Drops(0) Stalls(0)
45     NIC: InDisc(0) OutDisc(0) Fctls(0) Stalls(0) Hangs(0) Muted(0)
46     Bandwidth thresholds are not set.
47 5)   Interface 10/3 (10G Ethernet) #19
48     flags=0x4000 &lt;ENABLED, DOWN, down, autoneg, HAMON, 802.1q&gt;
49     ;
50     MTU=1500, native vlan=1, MAC=68:05:ca:30:e1:42, downtime 44
51     h00m08s
52     Requested: media AUTO, speed AUTO, duplex AUTO, fctl OFF,
53     throughput 0
54     LLDP Mode: NONE
55     RX: Pkts(0) Bytes(0) Errs(0) Drops(0) Stalls(0)
56     TX: Pkts(0) Bytes(0) Errs(0) Drops(0) Stalls(0)
57     NIC: InDisc(0) OutDisc(0) Fctls(0) Stalls(0) Hangs(0) Muted(0)
58     Bandwidth thresholds are not set.
59 6)   Interface 10/4 (10G Ethernet) #20
60     flags=0x4000 &lt;ENABLED, DOWN, down, autoneg, HAMON, 802.1q&gt;
61     ;
62     MTU=1500, native vlan=1, MAC=68:05:ca:30:e1:43, downtime 44
63     h00m08s
64     Requested: media AUTO, speed AUTO, duplex AUTO, fctl OFF,
65     throughput 0
66     LLDP Mode: NONE
67     RX: Pkts(0) Bytes(0) Errs(0) Drops(0) Stalls(0)
68     TX: Pkts(0) Bytes(0) Errs(0) Drops(0) Stalls(0)
69     NIC: InDisc(0) OutDisc(0) Fctls(0) Stalls(0) Hangs(0) Muted(0)
70     Bandwidth thresholds are not set.
71 7)   Interface 10/5 (10G Ethernet) #13

```



```
64     flags=0x4000 &lt;ENABLED, DOWN, down, autoneg, HAMON, 802.1q&gt;
65     ;
66     MTU=1500, native vlan=1, MAC=68:05:ca:2e:6b:a0, downtime 44
67     h00m08s
68     Requested: media AUTO, speed AUTO, duplex AUTO, fctl OFF,
69     throughput 0
70     LLDP Mode: NONE
71     RX: Pkts(0) Bytes(0) Errs(0) Drops(0) Stalls(0)
72     TX: Pkts(0) Bytes(0) Errs(0) Drops(0) Stalls(0)
73     NIC: InDisc(0) OutDisc(0) Fctls(0) Stalls(0) Hangs(0) Muted(0)
74     Bandwidth thresholds are not set.
75 8)   Interface 10/6 (10G Ethernet) #14
76     flags=0x4000 &lt;ENABLED, DOWN, down, autoneg, HAMON, 802.1q&gt;
77     ;
78     MTU=1500, native vlan=1, MAC=68:05:ca:2e:6b:a1, downtime 44
79     h00m08s
80     Requested: media AUTO, speed AUTO, duplex AUTO, fctl OFF,
81     throughput 0
82     LLDP Mode: NONE
83     RX: Pkts(0) Bytes(0) Errs(0) Drops(0) Stalls(0)
84     TX: Pkts(0) Bytes(0) Errs(0) Drops(0) Stalls(0)
85     NIC: InDisc(0) OutDisc(0) Fctls(0) Stalls(0) Hangs(0) Muted(0)
86     Bandwidth thresholds are not set.
87 9)   Interface 10/7 (10G Ethernet) #15
88     flags=0x4000 &lt;ENABLED, DOWN, down, autoneg, HAMON, 802.1q&gt;
89     ;
90     MTU=1500, native vlan=1, MAC=68:05:ca:2e:6b:a2, downtime 44
91     h00m08s
92     Requested: media AUTO, speed AUTO, duplex AUTO, fctl OFF,
93     throughput 0
94     LLDP Mode: NONE
95     RX: Pkts(0) Bytes(0) Errs(0) Drops(0) Stalls(0)
96     TX: Pkts(0) Bytes(0) Errs(0) Drops(0) Stalls(0)
97     NIC: InDisc(0) OutDisc(0) Fctls(0) Stalls(0) Hangs(0) Muted(0)
98     Bandwidth thresholds are not set.
99 10)  Interface 10/8 (10G Ethernet) #16
100    flags=0x4000 &lt;ENABLED, DOWN, down, autoneg, HAMON, 802.1q&gt;
101    ;
102    MTU=1500, native vlan=1, MAC=68:05:ca:2e:6b:a3, downtime 44
103    h00m08s
104    Requested: media AUTO, speed AUTO, duplex AUTO, fctl OFF,
105    throughput 0
106    LLDP Mode: NONE
107    RX: Pkts(0) Bytes(0) Errs(0) Drops(0) Stalls(0)
108    TX: Pkts(0) Bytes(0) Errs(0) Drops(0) Stalls(0)
109    NIC: InDisc(0) OutDisc(0) Fctls(0) Stalls(0) Hangs(0) Muted(0)
110    Bandwidth thresholds are not set.
111 11)  Interface 10/9 (10G Ethernet) #0
112    flags=0x4000 &lt;ENABLED, DOWN, down, autoneg, HAMON, 802.1q&gt;
113    ;
114    MTU=1500, native vlan=1, MAC=68:05:ca:30:e1:a0, downtime 44
115    h00m08s
116    Requested: media AUTO, speed AUTO, duplex AUTO, fctl OFF,
117    throughput 0
118    LLDP Mode: NONE
```

```
109     RX: Pkts(0) Bytes(0) Errs(0) Drops(0) Stalls(0)
110     TX: Pkts(0) Bytes(0) Errs(0) Drops(0) Stalls(0)
111     NIC: InDisc(0) OutDisc(0) Fctls(0) Stalls(0) Hangs(0) Muted(0)
112     Bandwidth thresholds are not set.
113 12)   Interface 10/10 (10G Ethernet) #1
114     flags=0x4000 &lt;ENABLED, DOWN, down, autoneg, HAMON, 802.1q&gt;
115     ;
116     MTU=1500, native vlan=1, MAC=68:05:ca:30:e1:a1, downtime 44
117     h00m08s
118     Requested: media AUTO, speed AUTO, duplex AUTO, fctl OFF,
119     throughput 0
120     LLDP Mode: NONE
121     RX: Pkts(0) Bytes(0) Errs(0) Drops(0) Stalls(0)
122     TX: Pkts(0) Bytes(0) Errs(0) Drops(0) Stalls(0)
123     NIC: InDisc(0) OutDisc(0) Fctls(0) Stalls(0) Hangs(0) Muted(0)
124     Bandwidth thresholds are not set.
125 13)   Interface 10/11 (10G Ethernet) #2
126     flags=0x4000 &lt;ENABLED, DOWN, down, autoneg, HAMON, 802.1q&gt;
127     ;
128     MTU=1500, native vlan=1, MAC=68:05:ca:30:e1:a2, downtime 44
129     h00m08s
130     Requested: media AUTO, speed AUTO, duplex AUTO, fctl OFF,
131     throughput 0
132     LLDP Mode: NONE
133     RX: Pkts(0) Bytes(0) Errs(0) Drops(0) Stalls(0)
134     TX: Pkts(0) Bytes(0) Errs(0) Drops(0) Stalls(0)
135     NIC: InDisc(0) OutDisc(0) Fctls(0) Stalls(0) Hangs(0) Muted(0)
136     Bandwidth thresholds are not set.
137 14)   Interface 10/12 (10G Ethernet) #3
138     flags=0x4000 &lt;ENABLED, DOWN, down, autoneg, HAMON, 802.1q&gt;
139     ;
140     MTU=1500, native vlan=1, MAC=68:05:ca:30:e1:a3, downtime 44
141     h00m08s
142     Requested: media AUTO, speed AUTO, duplex AUTO, fctl OFF,
143     throughput 0
144     LLDP Mode: NONE
145     RX: Pkts(0) Bytes(0) Errs(0) Drops(0) Stalls(0)
146     TX: Pkts(0) Bytes(0) Errs(0) Drops(0) Stalls(0)
147     NIC: InDisc(0) OutDisc(0) Fctls(0) Stalls(0) Hangs(0) Muted(0)
148     Bandwidth thresholds are not set.
149 15)   Interface 10/13 (10G Ethernet) #4
150     flags=0x4000 &lt;ENABLED, DOWN, down, autoneg, HAMON, 802.1q&gt;
151     ;
152     MTU=1500, native vlan=1, MAC=68:05:ca:30:e2:70, downtime 44
153     h00m08s
154     Requested: media AUTO, speed AUTO, duplex AUTO, fctl OFF,
155     throughput 0
156     LLDP Mode: NONE
157     RX: Pkts(0) Bytes(0) Errs(0) Drops(0) Stalls(0)
158     TX: Pkts(0) Bytes(0) Errs(0) Drops(0) Stalls(0)
159     NIC: InDisc(0) OutDisc(0) Fctls(0) Stalls(0) Hangs(0) Muted(0)
```

```
154      Bandwidth thresholds are not set.
155  16)   Interface 10/14 (10G Ethernet) #5
156      flags=0x4000 &lt;ENABLED, DOWN, down, autoneg, HAMON, 802.1q&
157      gt;
158      MTU=1500, native vlan=1, MAC=68:05:ca:30:e2:71, downtime 44
159      h00m15s
160      Requested: media AUTO, speed AUTO, duplex AUTO, fctl OFF,
161      throughput 0
162      LLDP Mode: NONE
163      RX: Pkts(0) Bytes(0) Errs(0) Drops(0) Stalls(0)
164      TX: Pkts(0) Bytes(0) Errs(0) Drops(0) Stalls(0)
165      NIC: InDisc(0) OutDisc(0) Fctls(0) Stalls(0) Hangs(0) Muted(0)
166      Bandwidth thresholds are not set.
167  17)   Interface 10/15 (10G Ethernet) #6
168      flags=0x4000 &lt;ENABLED, DOWN, down, autoneg, HAMON, 802.1q&
169      gt;
170      MTU=1500, native vlan=1, MAC=68:05:ca:30:e2:72, downtime 44
171      h00m15s
172      Requested: media AUTO, speed AUTO, duplex AUTO, fctl OFF,
173      throughput 0
174      LLDP Mode: NONE
175      RX: Pkts(0) Bytes(0) Errs(0) Drops(0) Stalls(0)
176      TX: Pkts(0) Bytes(0) Errs(0) Drops(0) Stalls(0)
177      NIC: InDisc(0) OutDisc(0) Fctls(0) Stalls(0) Hangs(0) Muted(0)
178      Bandwidth thresholds are not set.
179  18)   Interface 10/16 (10G Ethernet) #7
180      flags=0x4000 &lt;ENABLED, DOWN, down, autoneg, HAMON, 802.1q&
181      gt;
182      MTU=1500, native vlan=1, MAC=68:05:ca:30:e2:73, downtime 44
183      h00m15s
184      Requested: media AUTO, speed AUTO, duplex AUTO, fctl OFF,
185      throughput 0
186      LLDP Mode: NONE
187      RX: Pkts(0) Bytes(0) Errs(0) Drops(0) Stalls(0)
188      TX: Pkts(0) Bytes(0) Errs(0) Drops(0) Stalls(0)
189      NIC: InDisc(0) OutDisc(0) Fctls(0) Stalls(0) Hangs(0) Muted(0)
190      Bandwidth thresholds are not set.
191  19)   Interface 40/1 (40G Ethernet) #9
192      flags=0x4000 &lt;ENABLED, DOWN, down, autoneg, HAMON, 802.1q&
193      gt;
194      MTU=1500, native vlan=1, MAC=3c:fd:fe:9c:f9:98, downtime 44
195      h00m15s
196      Requested: media AUTO, speed AUTO, duplex AUTO, fctl OFF,
197      throughput 0
198      LLDP Mode: NONE
199      RX: Pkts(0) Bytes(0) Errs(0) Drops(0) Stalls(0)
200      TX: Pkts(0) Bytes(0) Errs(0) Drops(0) Stalls(0)
201      NIC: InDisc(0) OutDisc(0) Fctls(0) Stalls(0) Hangs(0) Muted(0)
202      Bandwidth thresholds are not set.
203  20)   Interface 40/2 (40G Ethernet) #21
204      flags=0x4000 &lt;ENABLED, DOWN, down, autoneg, HAMON, 802.1q&
205      gt;
```

```

198      MTU=1500, native vlan=1, MAC=3c:fd:fe:9c:fa:68, downtime 44
199          h00m15s
200      Requested: media AUTO, speed AUTO, duplex AUTO, fctl OFF,
201          throughput 0
202      LLDP Mode: NONE
203      RX: Pkts(0) Bytes(0) Errs(0) Drops(0) Stalls(0)
204      TX: Pkts(0) Bytes(0) Errs(0) Drops(0) Stalls(0)
205      NIC: InDisc(0) OutDisc(0) Fctls(0) Stalls(0) Hangs(0) Muted(0)
206      Bandwidth thresholds are not set.
207  21)  Interface 40/3 (40G Ethernet) #12
208      flags=0x4000 &lt;ENABLED, DOWN, down, autoneg, HAMON, 802.1q&
209          gt;
210      MTU=1500, native vlan=1, MAC=3c:fd:fe:9c:f9:f8, downtime 44
211          h00m15s
212      Requested: media AUTO, speed AUTO, duplex AUTO, fctl OFF,
213          throughput 0
214      LLDP Mode: NONE
215      RX: Pkts(0) Bytes(0) Errs(0) Drops(0) Stalls(0)
216      TX: Pkts(0) Bytes(0) Errs(0) Drops(0) Stalls(0)
217      NIC: InDisc(0) OutDisc(0) Fctls(0) Stalls(0) Hangs(0) Muted(0)
218      Bandwidth thresholds are not set.
219  22)  Interface 40/4 (40G Ethernet) #8
220      flags=0x4000 &lt;ENABLED, DOWN, down, autoneg, HAMON, 802.1q&
221          gt;
222      MTU=1500, native vlan=1, MAC=3c:fd:fe:9c:f9:e0, downtime 44
223          h00m15s
224      Requested: media AUTO, speed AUTO, duplex AUTO, fctl OFF,
225          throughput 0
226      LLDP Mode: NONE
227      RX: Pkts(0) Bytes(0) Errs(0) Drops(0) Stalls(0)
228      TX: Pkts(0) Bytes(0) Errs(0) Drops(0) Stalls(0)
229      NIC: InDisc(0) OutDisc(0) Fctls(0) Stalls(0) Hangs(0) Muted(0)
230      Bandwidth thresholds are not set.
231  23)  Interface LO/1 (Netscaler Loopback interface) #22
232      flags=0x20008020 &lt;ENABLED, UP, UP&gt;
233      MTU=1500, native vlan=1, MAC=0c:c4:7a:41:ea:94, uptime 44
234          h00m15s
235      LLDP Mode: NONE
236      RX: Pkts(103847611) Bytes(14441166499) Errs(0) Drops(0) Stalls
237          (0)
238      TX: Pkts(206723664) Bytes(20488047637) Errs(0) Drops(0) Stalls
239          (0)
240      Bandwidth thresholds are not set.
241  Done

```

4. In the show interface command's output, verify that all of the interfaces are enabled and the status of every interface is shown as UP/UP.

Notes:

- The interface status is displayed as UP/UP only if the cables are connected to the interfaces.
- If you do not have an SFP+ transceiver for every port, verify the interfaces in stages. After check-

ing the first set of interfaces, unplug the SFP+ transceivers and plug them in to the next set of ports.

5. Run the following command for each of the interfaces that are not in the UP/UP state:

```
1 enable interface 10/x
2 enable interface 40/x
```

Where x is the new interface number.

Example:

```
1 enable interface 10/1
2 Done
3 > enable interface 40/1
4 Done
```

6. Run the following command to verify that the status of the power supplies is normal: stat system – detail

Example

```
1 stat system -detail
2 NetScaler Executive View
3 System Information:
4 Up since Mon Mar 21 13:53:22 2016
5 Memory usage (MB) 1177
6 InUse Memory (%) 5.37
7 Number of CPUs 7
8 System Health Statistics (Standard):
9 CPU 0 Core Voltage (Volts) 0.99
10 CPU 1 Core Voltage (Volts) 0.98
11 Main 3.3 V Supply Voltage 3.36
12 Standby 3.3 V Supply Voltage 3.31
13 +5.0 V Supply Voltage 5.06
14 +12.0 V Supply Voltage 12.08
15 Battery Voltage (Volts) 3.17
16 Intel CPU Vtt Power(Volts) 1.01
17 5V Standby Voltage(Volts) 0.00
18 Voltage Sensor2(Volts) 0.00
19 CPU Fan 0 Speed (RPM) 4650
20 CPU Fan 1 Speed (RPM) 4575
21 System Fan Speed (RPM) 4650
22 System Fan 1 Speed (RPM) 4650
23 System Fan 2 Speed (RPM) 4650
24 CPU 0 Temperature (Celsius) 42
25 CPU 1 Temperature (Celsius) 49
26 Internal Temperature (Celsius) 36
27 Power supply 1 status NORMAL
28 Power supply 2 status NORMAL
29 Power supply 3 status NOT SUPPORTED
30 Power supply 4 status NOT SUPPORTED
31 System Disk Statistics:
```

```
32 /flash Size (MB) 16858
33 /flash Used (MB) 186
34 /flash Available (MB) 15323
35 /flash Used (%) 1
36 /var Size (MB) 143802
37 /var Used (MB) 781
38 /var Available (MB) 131517
39 /var Used (%) 0
40 System Health Statistics(Auxiliary):
41 Voltage 0 (Volts) 1.49
42 Voltage 1 (Volts) 1.49
43 Voltage 2 (Volts) 1.50
44 Voltage 3 (Volts) 1.49
45 Voltage 4 (Volts) 1.49
46 Voltage 5 (Volts) 0.00
47 Voltage 6 (Volts) 0.00
48 Voltage 7 (Volts) 0.00
49 Fan 0 Speed (RPM) 4650
50 Fan 1 Speed (RPM) 0
51 Fan 2 Speed (RPM) 0
52 Fan 3 Speed (RPM) 0
53 Temperature 0 (Celsius) 28
54 Temperature 1 (Celsius) 43
55 Temperature 2 (Celsius) 0
56 Temperature 3 (Celsius) 0
57 Done
```

7. Run the following command to generate a tar of system configuration data and statistics: `show techsupport`

Example

```
1 show techsupport
2 showtechsupport data collector tool - $Revision: #2 $!
3 NetScaler version 10.5
4 Creating /var/tmp/support ....
5 The NS IP of this box is 192.168.100.1
6 Current HA state: Primary (or this is not part of HA pair!)
7 All the data will be collected under
8     /var/tmp/support/collector_P_192.168.100.1_23Mar2016_10_00
9 Copying selected configuration files from nsconfig ....
10 Copying WebInterface configuration files (if WI is installed) ....
11     .... WI is not installed on this system. Nothing to copy.
12 Running shell commands ....
13 Running CLI show commands ....
14 Running CLI stat commands ....
15 Running vtysh commands ....
16 Determining newslog files to archive ....
17     Last newslog file index=1
18     Warning! Missing newslog.0 and newslog.0.tar and newslog.0.
19     tar.gz file!
20     Warning! Missing newslog.199 and newslog.199.tar and
21     newslog.199.tar.gz file!
```

```

20      Warning! Missing newslog.198 and newslog.198.tar and
      newslog.198.tar.gz file!
21      Warning! Missing newslog.197 and newslog.197.tar and
      newslog.197.tar.gz file!
22      Warning! Missing newslog.196 and newslog.196.tar and
      newslog.196.tar.gz file!
23      Five newslog files missing
24
25      .... copied 2 files from this directory.
26      Copying core files from /var/core .... (last 5 files created within
      the last week)
27      .... Nothing to copy .... No files created within the last one
      week
28      Copying core files from /var/crash .... (last 5 files created within
      the last week)
29      .... Nothing to copy .... No files created within the last one
      week
30      Copying imported files and mapping files ....
31      Copying GSLB location database files ....
32      Copying files from /var/log/db ....
33      Copying messages,ns.log,dmesg and other log files ....
34      Warning : cluster showtech node failure log file: /var/tmp/support/
      collector_P_192.168.100.1_23Mar2016_10_00/
      cluster_showtech_node_failure.log is not present
35      Archiving all the data into &quot;/var/tmp/support/collector_P_192
      .168.100.1_23Mar2016_10_00.tar.gz&quot; ....
36      Created a symbolic link for the archive with /var/tmp/support/support.
      tgz
37      /var/tmp/support/support.tgz ---- points to ---&gt; /var/tmp/support/
      collector_P_192.168.100.1_23Mar2016_10_00.tar.gz
38      If this node is part of HA pair, please run it on the other node also
      !!
39      Done

```

Note: The output of the command is available in the /var/tmp/support/collector_<IP_address>_P_<date>.tar.gz file. Copy this file to another computer for future reference. The output of the command might be helpful when you want to contact Citrix technical support.

8. At the command line interface, switch to the shell prompt. Type: `shell`

Example

```

1  shell
2  Copyright (c) 1992-2013 The FreeBSD Project.
3  Copyright (c) 1979, 1980, 1983, 1986, 1988, 1989, 1991, 1992, 1993,
   1994
4      The Regents of the University of California. All rights
      reserved.

```

9. Run the following command to verify the number of Cavium cards available depending upon your appliance:

```
root@ns# grep "cavium"/var/nslog/dmesg.boot
```

Example

```

1 /var/nslog/dmesg.boot
2 Cavium cavium_probe : found card 0x177d,device=0x11
3 cavium0 mem 0xde200000-0xde2fffff irq 32 at device 0.0 on pci3
4 cavium0: [ITHREAD]
5 Cavium cavium_probe : found card 0x177d,device=0x11
6 cavium1 mem 0xfb400000-0xfb4fffff irq 64 at device 0.0 on pci136
7 cavium1: [ITHREAD]
8 Cavium cavium_probe : found card 0x177d,device=0x11
9 cavium0 mem 0xde200000-0xde2fffff irq 32 at device 0.0 on pci3
10 cavium0: [ITHREAD]
11 Cavium cavium_probe : found card 0x177d,device=0x11
12 cavium1 mem 0xfb400000-0xfb4fffff irq 64 at device 0.0 on pci136
13 cavium1: [ITHREAD]
14 root@ns#

```

10. Run the following command to verify the RAM memory reserved for shared memory depending upon your appliance:

```
root@ns# grep "memory"/var/nslog/dmesg.boot
```

Example

```

1 /var/nslog/dmesg.boot
2 real memory = 70866960384 (67584 MB)
3 avail memory = 66206515200 (63139 MB)
4 NS-KERN map_shared_mem_ioctl (cpu 11, NSPPE-00): Reserving 596 MB for
   shared memory type 0
5 real memory = 70866960384 (67584 MB)
6 avail memory = 66206515200 (63139 MB)
7 root@ns#

```

11. Run the following command to verify the number of CPU cores depending upon your appliance:

```
root@ns# grep "cpu"/var/nslog/dmesg.boot
```

Example

```

1 root@ns# grep "cpu" /var/nslog/dmesg.boot
2 cpu0 (BSP): APIC ID: 0
3 cpu1 (AP): APIC ID: 2
4 cpu2 (AP): APIC ID: 4
5 cpu3 (AP): APIC ID: 6
6 cpu4 (AP): APIC ID: 8
7 cpu5 (AP): APIC ID: 10
8 cpu6 (AP): APIC ID: 32
9 cpu7 (AP): APIC ID: 34
10 cpu8 (AP): APIC ID: 36
11 cpu9 (AP): APIC ID: 38
12 cpu10 (AP): APIC ID: 40
13 cpu11 (AP): APIC ID: 42
14 cpu0: <ACPI CPU> on acpi0
15 cpu1: <ACPI CPU> on acpi0

```



```
16  cpu2: <ACPI CPU> on acpi0
17  cpu3: <ACPI CPU> on acpi0
18  cpu4: <ACPI CPU> on acpi0
19  cpu5: <ACPI CPU> on acpi0
20  cpu6: <ACPI CPU> on acpi0
21  cpu7: <ACPI CPU> on acpi0
22  cpu8: <ACPI CPU> on acpi0
23  cpu9: <ACPI CPU> on acpi0
24  cpu10: <ACPI CPU> on acpi0
25  cpu11: <ACPI CPU> on acpi0
26  est0: <Enhanced SpeedStep Frequency Control> on cpu0
27  p4tcc0: <CPU Frequency Thermal Control> on cpu0
28  est1: <Enhanced SpeedStep Frequency Control> on cpu1
29  p4tcc1: <CPU Frequency Thermal Control> on cpu1
30  est2: <Enhanced SpeedStep Frequency Control> on cpu2
31  p4tcc2: <CPU Frequency Thermal Control> on cpu2
32  est3: <Enhanced SpeedStep Frequency Control> on cpu3
33  p4tcc3: <CPU Frequency Thermal Control> on cpu3
34  est4: <Enhanced SpeedStep Frequency Control> on cpu4
35  p4tcc4: <CPU Frequency Thermal Control> on cpu4
36  est5: <Enhanced SpeedStep Frequency Control> on cpu5
37  p4tcc5: <CPU Frequency Thermal Control> on cpu5
38  est6: <Enhanced SpeedStep Frequency Control> on cpu6
39  p4tcc6: <CPU Frequency Thermal Control> on cpu6
40  est7: <Enhanced SpeedStep Frequency Control> on cpu7
41  p4tcc7: <CPU Frequency Thermal Control> on cpu7
42  est8: <Enhanced SpeedStep Frequency Control> on cpu8
43  p4tcc8: <CPU Frequency Thermal Control> on cpu8
44  est9: <Enhanced SpeedStep Frequency Control> on cpu9
45  p4tcc9: <CPU Frequency Thermal Control> on cpu9
46  est10: <Enhanced SpeedStep Frequency Control> on cpu10
47  p4tcc10: <CPU Frequency Thermal Control> on cpu10
48  est11: <Enhanced SpeedStep Frequency Control> on cpu11
49  p4tcc11: <CPU Frequency Thermal Control> on cpu11
50  NS-KERN map_shared_mem_ioctl (cpu 11, NSPPE-00): Reserving 596 MB for
    shared memory type 0
51  cpu0 (BSP): APIC ID: 0
52  cpu1 (AP): APIC ID: 2
53  cpu2 (AP): APIC ID: 4
54  cpu3 (AP): APIC ID: 6
55  cpu4 (AP): APIC ID: 8
56  cpu5 (AP): APIC ID: 10
57  cpu6 (AP): APIC ID: 32
58  cpu7 (AP): APIC ID: 34
59  cpu8 (AP): APIC ID: 36
60  cpu9 (AP): APIC ID: 38
61  cpu10 (AP): APIC ID: 40
62  cpu11 (AP): APIC ID: 42
63  cpu0: <ACPI CPU> on acpi0
64  cpu1: <ACPI CPU> on acpi0
65  cpu2: <ACPI CPU> on acpi0
66  cpu3: <ACPI CPU> on acpi0
67  cpu4: <ACPI CPU> on acpi0
```

```

68  cpu5: <ACPI CPU> on acpi0
69  cpu6: <ACPI CPU> on acpi0
70  cpu7: <ACPI CPU> on acpi0
71  cpu8: <ACPI CPU> on acpi0
72  cpu9: <ACPI CPU> on acpi0
73  cpu10: <ACPI CPU> on acpi0
74  cpu11: <ACPI CPU> on acpi0
75  est0: <Enhanced SpeedStep Frequency Control> on cpu0
76  p4tcc0: <CPU Frequency Thermal Control> on cpu0
77  est1: <Enhanced SpeedStep Frequency Control> on cpu1
78  p4tcc1: <CPU Frequency Thermal Control> on cpu1
79  est2: <Enhanced SpeedStep Frequency Control> on cpu2
80  p4tcc2: <CPU Frequency Thermal Control> on cpu2
81  est3: <Enhanced SpeedStep Frequency Control> on cpu3
82  p4tcc3: <CPU Frequency Thermal Control> on cpu3
83  est4: <Enhanced SpeedStep Frequency Control> on cpu4
84  p4tcc4: <CPU Frequency Thermal Control> on cpu4
85  est5: <Enhanced SpeedStep Frequency Control> on cpu5
86  p4tcc5: <CPU Frequency Thermal Control> on cpu5
87  est6: <Enhanced SpeedStep Frequency Control> on cpu6
88  p4tcc6: <CPU Frequency Thermal Control> on cpu6
89  est7: <Enhanced SpeedStep Frequency Control> on cpu7
90  p4tcc7: <CPU Frequency Thermal Control> on cpu7
91  est8: <Enhanced SpeedStep Frequency Control> on cpu8
92  p4tcc8: <CPU Frequency Thermal Control> on cpu8
93  est9: <Enhanced SpeedStep Frequency Control> on cpu9
94  p4tcc9: <CPU Frequency Thermal Control> on cpu9
95  est10: <Enhanced SpeedStep Frequency Control> on cpu10
96  p4tcc10: <CPU Frequency Thermal Control> on cpu10
97  est11: <Enhanced SpeedStep Frequency Control> on cpu11
98  p4tcc11: <CPU Frequency Thermal Control> on cpu11
99  root@ns#

```

12. Run the following command to verify that the /var drive is mounted as /dev/ ar0s1a: root@ns# df -h

Example

```

1  root@ns# df -h
2  Filesystem      Size   Used  Avail Capacity  Mounted on
3  /dev/md0        327M   317M    3.1M    99%      /
4  devfs           1.0k   1.0k     0B    100%    /dev
5  procfs          4.0k   4.0k     0B    100%    /proc
6  /dev/ar0s1a     16G    186M    15G     1%     /flash
7  /dev/ar0s1e    140G   857M   128G     1%     /var
8  root@ns#

```

13. Type the following command to run the ns_hw_err.bash script, which checks for latent hardware errors: root@ns# ns_hw_err.bash

Example

```

1  root@ns# ns_hw_err.bash

```

```
2 NetScaler NS10.5: Build 59.71.nc, Date: Mar  2 2016, 05:22:19
3 platform: serial KZCHGCN810
4 platform: sysid 250140 - NSMPX-14000-40G 12*CPU+16*F1X+4*F4X+2*E1K+2*
  CVM N3
5 HDD MODEL: ar0: 227328MB &lt;Intel MatrixRAID RAID1&gt;; status: READY
6
7 Generating the list of newslog files to be processed...
8 Generating the events from newslog files...
9 Checking for HDD errors...
10 Checking for HDD SMART errors...
11 Checking for Flash errors...
12 /var/nslog/dmesg.boot:* DEVELOPER mode - run NetScaler manually! *
13 /var/tmp/ns_hw_tmp_10831//dmesg-a.out:* DEVELOPER mode - run NetScaler
  manually! *
14 *****
15 FOUND          2 Flash errors: DEVELOPER mode - run NetScaler manually
16 *****
17 Checking for Mega Raid Controller errors...
18 Checking for SSL errors...
19 Checking for BIOS errors...
20 Checking for SMB errors...
21 Checking for MotherBoard errors...
22 Checking for CMOS errors...
23     License year: 2016: OK
24 License server failed at startup. Check /var/log/license.log
25 Vendor daemon failed at startup. Check /var/log/license.log
26 Checking for SFP/NIC errors...
27 Checking for Firmware errors...
28 Checking for License errors...
29 Checking for Undetected CPUs...
30 Checking for DIMM flaps...
31 Checking for LOM errors...
32 Checking the Power Supply Errors...
33 root@ns#
```

14. **Important:** Physically disconnect all ports except the LOM port, including the management port, from the network.

15. At the shell prompt, switch to the NetScaler command line. Type: exit

Example

```
1 root@ns# exit
2  logout
3  Done
```

16. Run the following command to shut down the appliance. You are asked if you want to completely stop the NetScaler. Type: shutdown -p now

Example

```
1 root@ns#
2 root@ns# exit
```

- 3 Logout
- 4 Done

Upgrade the appliance

To upgrade the appliance, follow these steps:

1. Power off the NetScaler appliance.
2. Locate two solid-state drives (SSDs) on the back of the appliance in slot #1 and slot #2, as shown in the following figure:

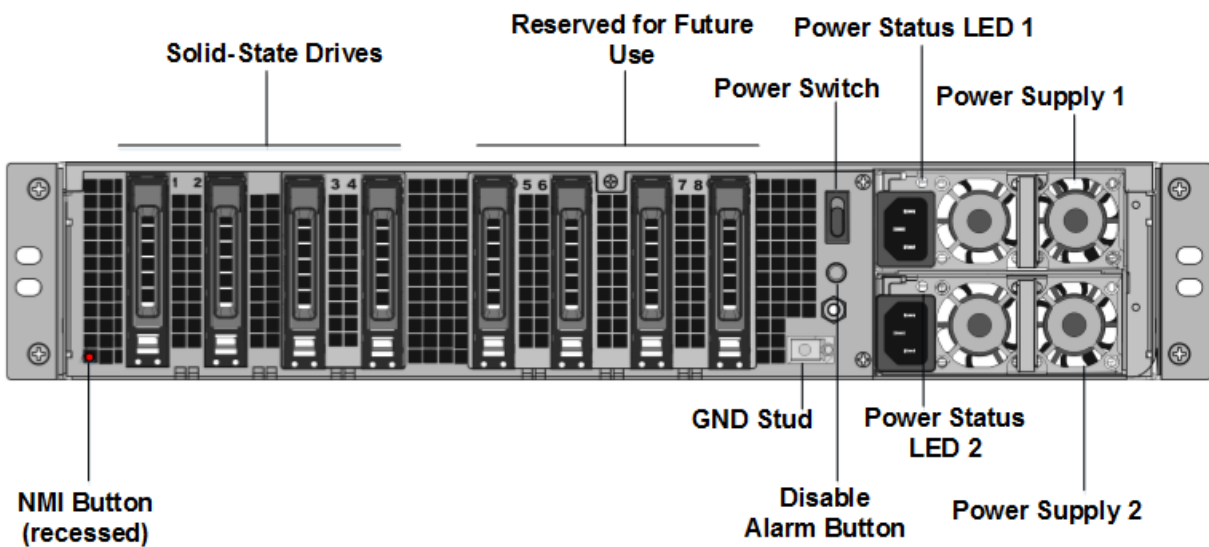

3. Verify that the replacement solid-state drives (SSDs) are the ones required for your NetScaler model. The conversion requires minimum of four SSDs. The NetScaler label is on the top of one of the solid-state drives, which is pre-populated with a new version of BIOS and a recent build of the required NetScaler SDX Management Service. This SSD must be installed in slot # 1.

4. Remove the SSDs by pushing the safety latch of the drive cover down while pulling the drive handle.

5. On the new NetScaler certified SSD drive, open the drive handle completely to the left, and then insert the new drive into the slot #1 as far as possible.

6. To seat the drive, close the handle flush with the rear side of the appliance so that the drive locks securely into the slot.

Important: The orientation of the SSD is important. When you insert the drive, make sure that the NetScaler product label is at the side.

7. Insert a second NetScaler certified SSD, which matches the capacity of the SSD in slot #1, in slot # 2.

Note: If the license of your appliance is 14040 40G, 14060 40G, 14080 40G, insert more blank NetScaler certified SSDs in slots #3, #4, #5, and #6.

NetScaler SDX Model	Included Virtual Instances	Platform Maximum	SSDs included on base model	Extra SSDs for max instances
SDX 14020 40G	5	25	Two 240 GB; Two 300 GB	Two 300 GB
SDX 14040 40G, SDX 14060 40G, SDX 14080 40G	25	25	Two 240 GB; Four 300 GB	N/A

Important: Mixing and matching of old and new SSDs is not supported. SSDs in slot #1 and slot #2, which constitute the first RAID pair (local storage), must be of the same size and type. Similarly, SSDs in slot #3 and slot #4, which constitute the second RAID pair (VPX storage), must be of the same size and type. Use only drives that are part of the provided conversion kit.

8. Disconnect all network cables from the data ports and the management ports.

9. Start the NetScaler appliance. For instructions, see “Switching on the Appliance” in Installing the Hardware.

The conversion process can run for approximately 30 minutes, during which you must not power cycle the appliance. The entire conversion process might not be visible on the console and might appear to be unresponsive.

The conversion process updates the BIOS, installs the Citrix Hypervisor and the Management Service Operating system, and copies the NetScaler VPX image to the SSD for instance provisioning, and forms the Raid1 pair.

Note: The serial number of the appliance remains the same.

10. Keep the console cable attached during the conversion process. Allow the process to complete, at which point the netscaler-sdx login: prompt appears.

11. During the conversion process the LOM port connection might be lost as it resets the IP address to the default value of 192.168.1.3. The conversion status output is available on the VGA monitor.

12. The default credentials are now changed from nsroot/nsroot to root/nsroot once the appliance is converted from an MPX to SDX.

13. To make sure that the conversion is successful, verify that the FVT result indicates success. Run the following command: `tail /var/log/fvt/fvt.log`

Reconfigure the converted appliance

After the conversion process, the appliance no longer has its previous working configuration. Therefore, you can access the appliance through a web browser only by using the default IP address: 192.168.100.1/16. Configure a computer on network 192.168.0.0 and connect it directly to the appliance's management port (0/1) with a cross-over Ethernet cable, or access the NetScaler SDX appliance through a network hub by using a straight through Ethernet cable. Use the default credentials to log on, and then do the following:

1. Select the Configuration tab.
2. Verify that the System Resource section displays the accurate number of CPU cores, SSL cores, and the total memory for your NetScaler SDX appliance.
3. Select the **System** node and, under **Set Up Appliance**, click **Network Configuration** to modify network information of the Management Service.
4. In the **Modify Network Configuration** dialog box, specify the following details:
 - Interface*—The interface through which clients connect to the Management Service. Possible values: 0/1, 0/2. Default: 0/1.
 - Citrix Hypervisor IP Address*—The IP address of Citrix Hypervisor.
 - Management Service IP Address*—The IP address of the Management Service.
 - Netmask*—The subnet mask for the subnet in which the SDX appliance is located.
 - Gateway*—The default gateway for the network.
 - DNS Server—The IP address of the DNS server.

*A mandatory parameter

1. Click OK. Connection to the Management Service is lost as the network information was changed.
2. Connect the NetScaler SDX appliance's management port 0/1 to a switch to access it through the network. Browse to the IP address used earlier and log on with the default credentials.
3. Apply the new licenses. For instructions, see [SDX Licensing Overview](#).
4. Navigate to **Configuration > System** and, in the **System Administration** group, click **Reboot Appliance**. Click **Yes** to confirm. You are now ready to provision the VPX instances on the NetScaler SDX appliance. For instructions, see [Provisioning NetScaler instances](#).

Convert a NetScaler MPX 8900 appliance to a NetScaler SDX 8900 appliance

December 31, 2023

You can convert a NetScaler MPX appliance to a NetScaler SDX appliance by upgrading the software through a new solid-state drive (SSD). NetScaler supplies a field conversion kit to migrate a NetScaler MPX appliance to a NetScaler SDX appliance.

Note

Citrix recommends that you configure the lights out management (LOM) port of the NetScaler appliance before starting the conversion process. For more information on the LOM port of the NetScaler appliance, see

[Lights out management port of the NetScaler appliance.](#)

To convert a NetScaler MPX appliance to a NetScaler SDX appliance, you must access the appliance through a console cable attached to a computer or terminal. Before connecting the console cable, configure the computer or terminal to support the following configuration:

- VT100 terminal emulation
- 9600 baud
- 8 data bits
- 1 stop bit
- Parity and flow control set to NONE

Connect one end of the console cable to the RS232 serial port on the appliance, and the other end to the computer or terminal.

Note

To use a cable with an RJ-45 converter, insert the optional converter into the console port and attach the cable to it.

With the cable attached, verify that the MPX appliance's components are functioning correctly. You are then ready to begin the conversion. The conversion process modifies the BIOS, installs a Citrix Hypervisor and a Service Virtual Machine image, and copies the NetScaler VPX image to the SSD.

After the conversion process, you modify the appliance's configuration and apply a new license. You can then provision the VPX instances through the Management Service on what is now a NetScaler SDX appliance.

The following figure shows the front panel of the MPX 89xx.

Figure 1. NetScaler MPX 89xx front panel

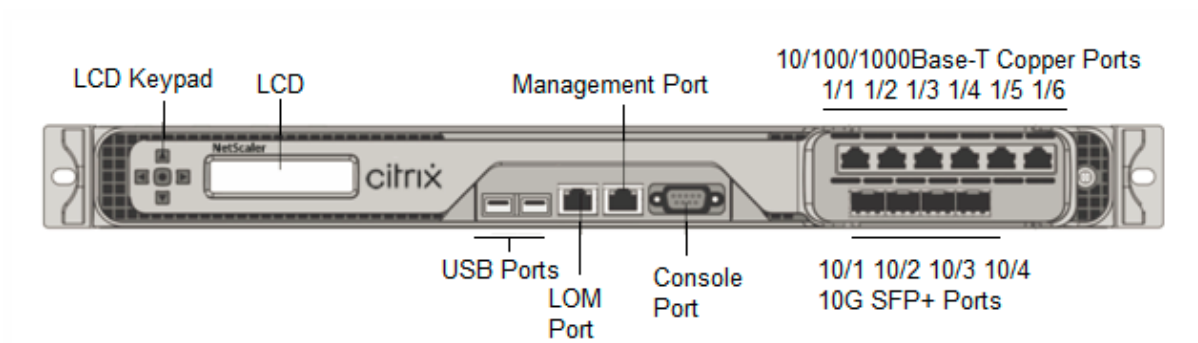

To verify proper operation of the MPX appliance’s components

1. Access the console port and enter the administrator credentials.
2. Run the following command from the command line interface of the appliance to display the serial number: **show hardware**

The serial number might be helpful in case you want to contact Citrix technical support.

Example

```

1 > show hardware
2 Platform: NSMPX-8900 8*CPU+4*F1X+6*E1K+1*E1K+1*COL 8955 30010
3 Manufactured on: 12/3/2018
4 CPU: 2100MHZ
5 Host Id: 1862303878
6 Serial no: JVFUJCZT1E
7 Encoded serial no: JVFUJCZT1E
8 BMC Revision: 4.51
9 Done
    
```

3. Run the following command to display the status of the active 1G and 10G interfaces: **show interface**
4. In the show interface command’s output, verify that all the interfaces are enabled and the status of every interface is shown as UP/UP.

Note
 If you do not have an SFP+ transceiver for every port, verify the interfaces in stages. After checking the first set of interfaces, unplug the SFP+ transceivers and plug them in to the next set of ports. The SFP+ transceivers are not hot-swappable. Therefore, restart the MPX appliance after you connect the transceivers.

5. Run the following commands for each of the interfaces that are not in the UP/UP state:
 - **enable interface 1/x**

- **enable interface 10/x**

where x is the new interface number.

6. Run the following command to verify that the status of the power supplies is normal: **stat system -detail**

Example

```

1 > stat system -detail
2 NetScaler Executive View
3 System Information:
4 Up since      Tue Dec  4 14:01:49 2018
5 Memory usage (MB)                859
6 InUse Memory (%)                 4.81
7 Number of CPUs                   5
8 System Health Statistics (Standard):
9 CPU 0 Core Voltage (Volts)       1.78
10 CPU 1 Core Voltage (Volts)      0.00
11 Main 3.3 V Supply Voltage       3.28
12 Standby 3.3 V Supply Voltage    3.28
13 +5.0 V Supply Voltage           4.90
14 +12.0 V Supply Voltage          11.81
15 Battery Voltage (Volts)         3.02
16 Intel CPU Vtt Power(Volts)      0.00
17 5V Standby Voltage(Volts)       5.05
18 Voltage Sensor2(Volts)          0.00
19 CPU Fan 0 Speed (RPM)           6900
20 CPU Fan 1 Speed (RPM)           6700
21 System Fan Speed (RPM)          6800
22 System Fan 1 Speed (RPM)        6800
23 System Fan 2 Speed (RPM)        6900
24 CPU 0 Temperature (Celsius)     44
25 CPU 1 Temperature (Celsius)     0
26 Internal Temperature (Celsius)  37
27 Power supply 1 status            NORMAL
28 Power supply 2 status            NORMAL
29 Power supply 3 status            NOT SUPPORTED
30 Power supply 4 status            NOT SUPPORTED
31 System Disk Statistics:
32 /flash Size (MB)                 16858
33 /flash Used (MB)                 323
34 /flash Available (MB)            15186
35 /flash Used (%)                  2
36 /var Size (MB)                   143802
37 /var Used (MB)                   1880
38 /var Available (MB)              130418
39 /var Used (%)                    1
40 System Health Statistics(Auxiliary):
41 Voltage 0 (Volts)                1.20
42 Voltage 1 (Volts)                1.20
43 Voltage 2 (Volts)                0.00
44 Voltage 3 (Volts)                0.00
45 Voltage 4 (Volts)                0.00

```

```
46 Voltage 5 (Volts) 0.00
47 Voltage 6 (Volts) 0.00
48 Voltage 7 (Volts) 0.00
49 Fan 0 Speed (RPM) 7000
50 Fan 1 Speed (RPM) 0
51 Fan 2 Speed (RPM) 0
52 Fan 3 Speed (RPM) 0
53 Temperature 0 (Celsius) 28
54 Temperature 1 (Celsius) 34
55 Temperature 2 (Celsius) 0
56 Temperature 3 (Celsius) 0
57 Done
```

7. Run the following command to generate a tar of system configuration data and statistics: **show techsupport**

Example

```
1 > show techsupport
2 showtechsupport data collector tool - $Revision: #13 $!
3 NetScaler version 11.1
4 Creating /var/tmp/support ....
5 The NS IP of this box is 10.221.44.30
6 This is not HA configuration
7 Copying selected configuration files ....
8 Running shell commands ....
9 Running CLI show commands ....
10 Collecting ns running configuration....
11 Collecting running gslb configuration....
12 Running CLI stat commands ....
13 Running vtysh commands ....
14 Copying newslog files ....
15 Copying core files from /var/core ....
16 Copying core files from /var/crash ....
17 Copying GSLB location database files ....
18 Copying GSLB auto sync log files ....
19 Copying Safenet Gateway log files ....
20 Copying messages, ns.log, dmesg and other log files ....
21 Creating archive ....
22 /var/tmp/support/support.tgz ---- points to ---> /var/tmp/support
   /collector_P_10.221.44.30_4Dec2018_14_14.tar.gz
23
24 Done
```

Note

The output of the command is available in the `/var/tmp/support/collector_<IP_address>_P_<date>.tar.gz` file. Copy this file to another computer for future reference. The output of the command might be helpful in case you want to contact Citrix technical support.

8. At the NetScaler command line interface, switch to the shell prompt. Type `shell`

9. Run the following command to verify that 270 MB of RAM is reserved for shared memory:

```
root@ns# dmesg | grep memory
```

Example

```
1 root@ns# dmesg | grep memory
2 real memory = 36507222016 (34816 MB)
3 avail memory = 32728735744 (31212 MB)
4 NS-KERN nsppe_rendezvous: NSPPE-02 on CPU3NS-KERN
   map_shared_mem_ioctl (cpu 2, NSPPE-01): Reserving 270 MB for
   shared memory type 0
5 root@ns#
```

10. Run the following command to verify that the appliance has 12 CPU cores: `root@ns# dmesg | grep cpu`

Example

```
1 root@ns# dmesg | grep cpu
2 cpu0 (BSP): APIC ID: 0
3 cpu1 (AP): APIC ID: 2
4 cpu2 (AP): APIC ID: 4
5 cpu3 (AP): APIC ID: 6
6 cpu4 (AP): APIC ID: 8
7 cpu5 (AP): APIC ID: 10
8 cpu6 (AP): APIC ID: 12
9 cpu7 (AP): APIC ID: 14
10 cpu0: <ACPI CPU> on acpi0
11 cpu1: <ACPI CPU> on acpi0
12 cpu2: <ACPI CPU> on acpi0
13 cpu3: <ACPI CPU> on acpi0
14 cpu4: <ACPI CPU> on acpi0
15 cpu5: <ACPI CPU> on acpi0
16 cpu6: <ACPI CPU> on acpi0
17 cpu7: <ACPI CPU> on acpi0
18 est0: <Enhanced SpeedStep Frequency Control> on cpu0
19 p4tcc0: <CPU Frequency Thermal Control> on cpu0
20 est1: <Enhanced SpeedStep Frequency Control> on cpu1
21 p4tcc1: <CPU Frequency Thermal Control> on cpu1
22 est2: <Enhanced SpeedStep Frequency Control> on cpu2
23 p4tcc2: <CPU Frequency Thermal Control> on cpu2
24 est3: <Enhanced SpeedStep Frequency Control> on cpu3
25 p4tcc3: <CPU Frequency Thermal Control> on cpu3
26 est4: <Enhanced SpeedStep Frequency Control> on cpu4
27 p4tcc4: <CPU Frequency Thermal Control> on cpu4
28 est5: <Enhanced SpeedStep Frequency Control> on cpu5
29 p4tcc5: <CPU Frequency Thermal Control> on cpu5
30 est6: <Enhanced SpeedStep Frequency Control> on cpu6
31 p4tcc6: <CPU Frequency Thermal Control> on cpu6
32 est7: <Enhanced SpeedStep Frequency Control> on cpu7
33 p4tcc7: <CPU Frequency Thermal Control> on cpu7
34 NS-KERN nsppe_rendezvous: NSPPE-02 on CPU3NS-KERN
   map_shared_mem_ioctl (cpu 2, NSPPE-01): Reserving 270 MB for
```

```
shared memory type 0
35 root@ns#
```

11. Run the following command to verify that the /var drive is mounted as /dev/ad0s1e: `root@ns# df -h`

Example

```
1 root@ns# df -h
2 Filesystem      Size      Used    Avail Capacity  Mounted on
3 /dev/md0        354M     342M      5M     99%      /
4 devfs          1.0k     1.0k      0B    100%    /dev
5 procfs         4.0k     4.0k      0B    100%    /proc
6 /dev/ad0s1a    16G     323M     14G      2%    /flash
7 /dev/ad0s1e   140G     1.9G    127G      1%    /var
8 root@ns#
```

12. Run the `ns_hw_err.bash` script, which checks for latent hardware errors: `root@ns# /netscaler/ns_hw_err.bash`

Example

```
1 root@ns# ns_hw_err.bash
2 NetScaler NS11.1: Build 60.5.nc, Date: Oct  3 2018, 10:58:21
3 platform: serial JVFUJCZT1E
4 platform: sysid 30010 - NSMPX-8900 8*CPU+4*F1X+6*E1K+1*E1K+1*COL
5 HDD MODEL: ad0: 228936MB <MICRON M510DC MTFDDAK240MBP 0013> at
6 ata0-master UDMA33
7
8 Generating the list of newslog files to be processed...
9 Generating the events from newslog files...
10 Checking for HDD errors...
11 Checking for HDD SMART errors...
12 Checking for Flash errors...
13     skipping flash check because HDD and flash are same physical
14     device: ad0.
15     Please refer to HDD error output.
16 Checking for Mega Raid Controller errors...
17 Checking for SSL errors...
18 Checking for BIOS errors...
19 Checking for SMB errors...
20 Checking for MotherBoard errors...
21 Checking for CMOS errors...
22     License year: 2018: OK
23 License server failed at startup. Check /var/log/license.log
24 Vendor daemon failed at startup. Check /var/log/license.log
25 Checking for SFP/NIC errors...
26 Checking for Firmware errors...
27 Checking for License errors...
28 Checking for Undetected CPUs...
29 Checking for DIMM flaps...
30 Checking for LOM errors...
```

```

29 Checking the Power Supply Errors...
30 Checking for Hardware Clock errors...
31 *****
32 NS hardware check: Found 2 errors
33 *****
34 Script Done.
35 root@ns#

```

13. **Important:** Physically disconnect all ports except the LOM port, including the management port, from the network.
14. At the shell prompt, switch to the NetScaler command line. Type: **exit**
15. Run the following command to shut down the appliance: `shutdown -p now`

Example

```

1 > shutdown -p now
2 Are you sure you want to completely stop NetScaler (Y/N)? [N]:y

```

Upgrade the appliance

The upgrade process involves the following two steps:

- Replace the SSD
- Start the appliance

Replace the SSD

1. Locate the solid-state drive on the back panel of the appliance, as shown in the following figure:

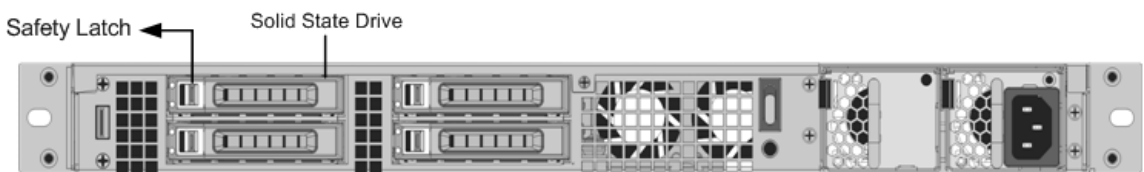

2. Verify that the replacement solid-state drive (SSD) is the one required for your NetScaler model. The NetScaler label is on the top of the SSD. The SSD is pre-populated with a new version of the BIOS and a recent build of the required Service VM software.
3. Remove the currently installed SSD drive by pushing the safety latch of the drive cover to the right and pulling out the drive by its handle.
4. Open the drive handle on the new drive completely to the left, and insert the drive into the slot. The following figure shows the drive partially inserted. Push the drive all the way into the slot.

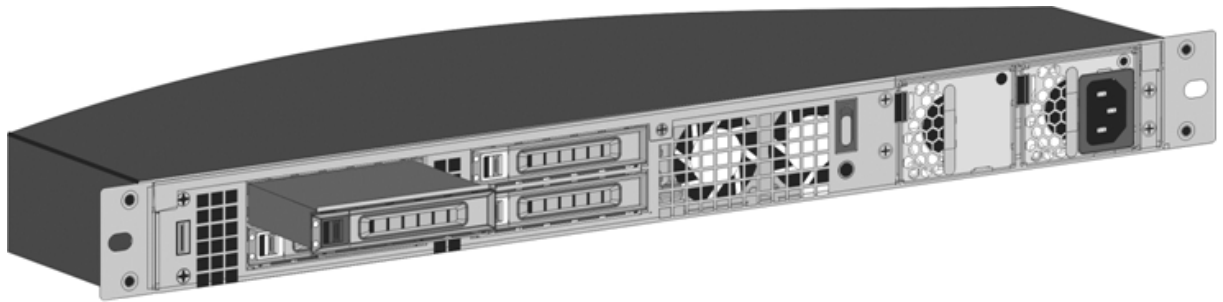

1. Close the handle flush with the rear side of the appliance so that the drive locks securely into the slot.

Important

The orientation of the solid-state drive is important. When you insert the drive, make sure that the NetScaler product label is at the top.

Start the appliance

1. Start the NetScaler appliance. For instructions, see the Switching on the Appliance section in [Installing the hardware](#).

The conversion process takes approximately 30 minutes to complete. The conversion process performs the following actions:

- Updates the BIOS.
- Installs the Citrix Hypervisor and the Service VM operating system.
- Copies the NetScaler VPX image to the solid state drive for instance provisioning.

When the conversion begins, the LCD screen on the front bezel indicates NSMPX-8900, as shown in the following figure.

```
1 ![SDX 8900 before conversion](/en-us/netscaler-hardware-platforms/sdx/
  media/89xx-before-conversion.png)
2
3 When the conversion is successful, the LCD indicates Citrix NSSDX -
  8900, as shown in the following figure.
4
5 ![SDX 8900 after conversion](/en-us/netscaler-hardware-platforms/sdx/
  media/89xx-after-conversion.png)
6
7 > **Note**
8 >
9 > The serial number of the appliance remains the same.
```

1. Keep the console cable attached during the conversion process. Allow the process to complete, at which point the netscaler-sdx login: prompt appears.

2. When the appliance finishes the conversion process, it no longer has the previously working configuration. Therefore, you can access the appliance through a Web browser only. Use the default IP address: 192.168.100.1/16. Configure a computer on network 192.168.0.0 and connect it directly to the management port 0/1 of the appliance by using a cross-over Ethernet cable. Alternately, access the appliance through a network hub by using a straight-through Ethernet cable. Use the default credentials.
3. Select the **Configuration** tab.
4. Verify that the System Resource section displays CPU cores, SSL cores, and total memory for the NetScaler SDX appliance.
5. Select System node and click the Network Configuration link on the System page to modify the IP address of the Service VM.
6. In the Modify Network Configuration dialog box, specify the following details:
 - Interface—The interface through which clients connect to the Management Service. Possible values: 0/1, 0/2. Default: 0/1.
 - Citrix Hypervisor IP Address—The IP address of the Citrix Hypervisor.
 - Management Service IP Address—The IP address of the Management Service.
 - Netmask—The subnet mask for the subnet in which the SDX appliance is located.
 - Gateway—The default gateway for the network.
 - DNS Server—The IP address of the DNS server. *An optional parameter
7. Click **OK**.
8. Connect the NetScaler SDX appliance to a switch to access it through the network. Browse to the Management Service IP and log on with the default credentials.
9. For instructions for applying the licenses, see [NetScaler SDX Licensing Overview](#).

Convert a NetScaler MPX 15000 appliance to a NetScaler SDX 15000 appliance

December 31, 2023

You can convert a NetScaler MPX appliance to an NetScaler SDX appliance by upgrading the software through a new solid-state drive (SSD). NetScaler supplies a field conversion kit to migrate a NetScaler MPX appliance to an SDX appliance.

The conversion requires all eight SSDs.

Note

Citrix recommends that you configure the lights out management (LOM) port of the appliance before starting the conversion process. For more information on the LOM port of the ADC appliance, see [Lights out management port of the NetScaler SDX appliance](#).

To convert an MPX appliance to an SDX appliance, you must access the appliance through a console cable attached to a computer or terminal. Before connecting the console cable, configure the computer or terminal to support the following configuration:

- VT100 terminal emulation
- 9600 baud
- 8 data bits
- 1 stop bit
- Parity and flow control set to NONE

Connect one end of the console cable to the RS232 serial port on the appliance, and the other end to the computer or terminal.

Note

To use a cable with an RJ-45 converter, insert the optional converter into the console port and attach the cable to it.

Citrix recommends you to connect a VGA monitor to the appliance to monitor the conversion process, because the LOM connection is lost during the conversion process.

With the cable attached, verify that the MPX appliance's components are functioning correctly. You are then ready to begin the conversion. The conversion process modifies the BIOS, installs a Citrix Hypervisor and a Service Virtual Machine image, and copies the NetScaler VPX image to the Solid State Drive.

The conversion process also sets up a redundant array of independent disks (RAID) controller for local storage and NetScaler VPX storage. SSD slots #1 and #2 are used for local storage and SSD slots #3 and #4 are used for NetScaler VPX storage.

After the conversion process, modify the appliance's configuration and apply a new license. You can then provision the VPX instances through the Management Service on what is now an NetScaler SDX appliance.

Verify proper operation of the MPX appliance's components

1. Access the console port and enter the administrator credentials.

2. Run the following command from the command line interface of the appliance to display the serial number: `show hardware`. You might need the serial number to log on to the appliance after the conversion.

Example

```
1 > show hardware
2 Platform: NSMPX-15000-50G 16*CPU+128GB+4*MLX(50)+8*F1X+2*E1K+2*2-
  CHIP COL 520400
3 Manufactured on: 9/13/2017
4 CPU: 2100MHZ
5 Host Id: 1862303878
6 Serial no: 4VCX9CUFN6
7 Encoded serial no: 4VCX9CUFN6
8 Netscaler UUID: d9de2de3-dc89-11e7-ab53-00e0ed5de5aa
9 BMC Revision: 5.56
10 Done
```

The serial number might be helpful when you want to contact Citrix technical support.

3. Run the following command to display the status of the active interfaces:

`show interface`

Example

```
1 > show interface
2
3 1) Interface 0/1 (Gig Ethernet 10/100/1000 Mbits) #4
4   flags=0xc020 <ENABLED, UP, UP, autoneg, HAMON, HEARTBEAT,
   802.1q>
5   MTU=1500, native vlan=1, MAC=0c:c4:7a:e5:3c:50, uptime 1
   h08m02s
6   Requested: media AUTO, speed AUTO, duplex AUTO, fctl OFF,
7   throughput 0
8   Actual: media UTP, speed 1000, duplex FULL, fctl OFF,
   throughput 1000
9   LLDP Mode: NONE, LR Priority: 1024
10
11  RX: Pkts(19446) Bytes(1797757) Errs(0) Drops(19096) Stalls(0)
12  TX: Pkts(368) Bytes(75619) Errs(0) Drops(0) Stalls(0)
13  NIC: InDisc(0) OutDisc(0) Fctls(0) Stalls(0) Hangs(0) Muted(0)
14  Bandwidth thresholds are not set.
15
16 2) Interface 0/2 (Gig Ethernet 10/100/1000 Mbits) #5
17  flags=0x4000 <ENABLED, DOWN, down, autoneg, HEARTBEAT, 802.1q>
18  MTU=1500, native vlan=1, MAC=0c:c4:7a:e5:3c:51, downtime 1
   h08m15s
19  Requested: media AUTO, speed AUTO, duplex AUTO, fctl OFF,
20  throughput 0
21  LLDP Mode: NONE, LR Priority: 1024
22
23  RX: Pkts(0) Bytes(0) Errs(0) Drops(0) Stalls(0)
24  TX: Pkts(0) Bytes(0) Errs(0) Drops(0) Stalls(0)
```

```
25 NIC: InDisc(0) OutDisc(0) Fctls(0) Stalls(0) Hangs(0) Muted(0)
26 Bandwidth thresholds are not set.
27
28 3) Interface 10/1 (10G Ethernet) #6
29 flags=0x4000 <ENABLED, DOWN, down, autoneg, HAMON, HEARTBEAT,
30 802.1q>
31 MTU=1500, native vlan=200, MAC=00:e0:ed:5d:e5:76, downtime 1
32 h08m15s
33 Requested: media AUTO, speed AUTO, duplex AUTO, fctl OFF,
34 throughput 0
35 LLDP Mode: NONE, LR Priority: 1024
36
37 RX: Pkts(0) Bytes(0) Errs(0) Drops(0) Stalls(0)
38 TX: Pkts(0) Bytes(0) Errs(0) Drops(0) Stalls(0)
39 NIC: InDisc(0) OutDisc(0) Fctls(0) Stalls(0) Hangs(0) Muted(0)
40 Bandwidth thresholds are not set.
41 Rx Ring: Configured size=2048, Actual size=512, Type: Elastic
42
43 4) Interface 10/2 (10G Ethernet) #7
44 flags=0x4000 <ENABLED, DOWN, down, autoneg, HEARTBEAT, 802.1q>
45 MTU=1500, native vlan=200, MAC=00:e0:ed:5d:e5:77, downtime 1
46 h08m15s
47 Requested: media AUTO, speed AUTO, duplex AUTO, fctl OFF,
48 throughput 0
49 LLDP Mode: NONE, LR Priority: 1024
50
51 RX: Pkts(0) Bytes(0) Errs(0) Drops(0) Stalls(0)
52 TX: Pkts(0) Bytes(0) Errs(0) Drops(0) Stalls(0)
53 NIC: InDisc(0) OutDisc(0) Fctls(0) Stalls(0) Hangs(0) Muted(0)
54 Bandwidth thresholds are not set.
55 Rx Ring: Configured size=2048, Actual size=512, Type: Elastic
56
57 5) Interface 10/3 (10G Ethernet) #8
58 flags=0x4000 <ENABLED, DOWN, down, autoneg, HEARTBEAT, 802.1q>
59 MTU=1500, native vlan=1, MAC=00:e0:ed:5d:e5:78, downtime 1
60 h08m15s
61 Requested: media AUTO, speed AUTO, duplex AUTO, fctl OFF,
62 throughput 0
63 LLDP Mode: NONE, LR Priority: 1024
64
65 RX: Pkts(0) Bytes(0) Errs(0) Drops(0) Stalls(0)
66 TX: Pkts(0) Bytes(0) Errs(0) Drops(0) Stalls(0)
67 NIC: InDisc(0) OutDisc(0) Fctls(0) Stalls(0) Hangs(0) Muted(0)
68 Bandwidth thresholds are not set.
69 Rx Ring: Configured size=2048, Actual size=512, Type: Elastic
70
71 6) Interface 10/4 (10G Ethernet) #9
72 flags=0x4000 <ENABLED, DOWN, down, autoneg, HEARTBEAT, 802.1q>
73 MTU=1500, native vlan=1, MAC=00:e0:ed:5d:e5:79, downtime 1
74 h08m15s
75 Requested: media AUTO, speed AUTO, duplex AUTO, fctl OFF,
76 throughput 0
77 LLDP Mode: NONE, LR Priority: 1024
```

```
73
74     RX: Pkts(0) Bytes(0) Errs(0) Drops(0) Stalls(0)
75     TX: Pkts(0) Bytes(0) Errs(0) Drops(0) Stalls(0)
76     NIC: InDisc(0) OutDisc(0) Fctls(0) Stalls(0) Hangs(0) Muted(0)
77     Bandwidth thresholds are not set.
78     Rx Ring: Configured size=2048, Actual size=512, Type: Elastic
79
80 7) Interface 10/5 (10G Ethernet) #0
81     flags=0x4000 <ENABLED, DOWN, down, autoneg, HEARTBEAT, 802.1q>
82     MTU=1500, native vlan=1, MAC=00:e0:ed:5d:e5:aa, downtime 1
83         h08m15s
84     Requested: media AUTO, speed AUTO, duplex AUTO, fctl OFF,
85         throughput 0
86     LLDP Mode: NONE,                LR Priority: 1024
87
88     RX: Pkts(0) Bytes(0) Errs(0) Drops(0) Stalls(0)
89     TX: Pkts(0) Bytes(0) Errs(0) Drops(0) Stalls(0)
90     NIC: InDisc(0) OutDisc(0) Fctls(0) Stalls(0) Hangs(0) Muted(0)
91     Bandwidth thresholds are not set.
92     Rx Ring: Configured size=2048, Actual size=512, Type: Elastic
93
94 8) Interface 10/6 (10G Ethernet) #1
95     flags=0x4000 <ENABLED, DOWN, down, autoneg, HEARTBEAT, 802.1q>
96     MTU=1500, native vlan=1, MAC=00:e0:ed:5d:e5:ab, downtime 1
97         h08m15s
98     Requested: media AUTO, speed AUTO, duplex AUTO, fctl OFF,
99         throughput 0
100    LLDP Mode: NONE,                LR Priority: 1024
101
102    RX: Pkts(0) Bytes(0) Errs(0) Drops(0) Stalls(0)
103    TX: Pkts(0) Bytes(0) Errs(0) Drops(0) Stalls(0)
104    NIC: InDisc(0) OutDisc(0) Fctls(0) Stalls(0) Hangs(0) Muted(0)
105    Bandwidth thresholds are not set.
106    Rx Ring: Configured size=2048, Actual size=512, Type: Elastic
107
108 9) Interface 10/7 (10G Ethernet) #2
109     flags=0x4000 <ENABLED, DOWN, down, autoneg, HEARTBEAT, 802.1q>
110     MTU=1500, native vlan=1, MAC=00:e0:ed:5d:e5:ac, downtime 1
111         h08m15s
112     Requested: media AUTO, speed AUTO, duplex AUTO, fctl OFF,
113         throughput 0
114     LLDP Mode: NONE,                LR Priority: 1024
115
116     RX: Pkts(0) Bytes(0) Errs(0) Drops(0) Stalls(0)
117     TX: Pkts(0) Bytes(0) Errs(0) Drops(0) Stalls(0)
118     NIC: InDisc(0) OutDisc(0) Fctls(0) Stalls(0) Hangs(0) Muted(0)
119     Bandwidth thresholds are not set.
120     Rx Ring: Configured size=2048, Actual size=512, Type: Elastic
121
122 10) Interface 10/8 (10G Ethernet) #3
123     flags=0x4000 <ENABLED, DOWN, down, autoneg, HEARTBEAT, 802.1q>
124     MTU=1500, native vlan=1, MAC=00:e0:ed:5d:e5:ad, downtime 1
125         h08m15s
```

```
122 Requested: media AUTO, speed AUTO, duplex AUTO, fctl OFF,
123 throughput 0
124 LLDP Mode: NONE, LR Priority: 1024
125
126 RX: Pkts(0) Bytes(0) Errs(0) Drops(0) Stalls(0)
127 TX: Pkts(0) Bytes(0) Errs(0) Drops(0) Stalls(0)
128 NIC: InDisc(0) OutDisc(0) Fctls(0) Stalls(0) Hangs(0) Muted(0)
129 Bandwidth thresholds are not set.
130 Rx Ring: Configured size=2048, Actual size=512, Type: Elastic
131
132 11) Interface 50/1 (50G Ethernet) #13
133 flags=0x4000 <ENABLED, DOWN, down, autoneg, HEARTBEAT, 802.1q>
134 MTU=1500, native vlan=1, MAC=24:8a:07:a3:1f:84, downtime 1
135 h08m22s
136 Requested: media AUTO, speed AUTO, duplex AUTO, fctl OFF,
137 throughput 0
138 LLDP Mode: NONE, LR Priority: 1024
139
140 RX: Pkts(0) Bytes(0) Errs(0) Drops(0) Stalls(0)
141 TX: Pkts(0) Bytes(0) Errs(0) Drops(0) Stalls(0)
142 NIC: InDisc(0) OutDisc(0) Fctls(0) Stalls(0) Hangs(0) Muted(0)
143 Bandwidth thresholds are not set.
144
145 12) Interface 50/2 (50G Ethernet) #12
146 flags=0x4000 <ENABLED, DOWN, down, autoneg, HEARTBEAT, 802.1q>
147 MTU=1500, native vlan=1, MAC=24:8a:07:a3:1f:6c, downtime 1
148 h08m22s
149 Requested: media AUTO, speed AUTO, duplex AUTO, fctl OFF,
150 throughput 0
151 LLDP Mode: NONE, LR Priority: 1024
152
153 RX: Pkts(0) Bytes(0) Errs(0) Drops(0) Stalls(0)
154 TX: Pkts(0) Bytes(0) Errs(0) Drops(0) Stalls(0)
155 NIC: InDisc(0) OutDisc(0) Fctls(0) Stalls(0) Hangs(0) Muted(0)
156 Bandwidth thresholds are not set.
157
158 13) Interface 50/3 (50G Ethernet) #11
159 flags=0x4000 <ENABLED, DOWN, down, autoneg, HEARTBEAT, 802.1q>
160 MTU=1500, native vlan=1, MAC=24:8a:07:a3:1f:98, downtime 1
161 h08m22s
162 Requested: media AUTO, speed AUTO, duplex AUTO, fctl OFF,
163 throughput 0
164 LLDP Mode: NONE, LR Priority: 1024
165
166 RX: Pkts(0) Bytes(0) Errs(0) Drops(0) Stalls(0)
167 TX: Pkts(0) Bytes(0) Errs(0) Drops(0) Stalls(0)
168 NIC: InDisc(0) OutDisc(0) Fctls(0) Stalls(0) Hangs(0) Muted(0)
169 Bandwidth thresholds are not set.
170
171 14) Interface 50/4 (50G Ethernet) #10
172 flags=0x4000 <ENABLED, DOWN, down, autoneg, HEARTBEAT, 802.1q>
173 MTU=1500, native vlan=1, MAC=24:8a:07:94:b9:b6, downtime 1
174 h08m22s
```

```

171 Requested: media AUTO, speed AUTO, duplex AUTO, fctl OFF,
172 throughput 0
173 LLDP Mode: NONE, LR Priority: 1024
174
175 RX: Pkts(0) Bytes(0) Errs(0) Drops(0) Stalls(0)
176 TX: Pkts(0) Bytes(0) Errs(0) Drops(0) Stalls(0)
177 NIC: InDisc(0) OutDisc(0) Fctls(0) Stalls(0) Hangs(0) Muted(0)
178 Bandwidth thresholds are not set.
179
180 15) Interface L0/1 (Netscaler Loopback interface) #14
181 flags=0x20008020 <ENABLED, UP, UP>
182 MTU=1500, native vlan=1, MAC=0c:c4:7a:e5:3c:50, uptime 1
    h08m18s
183 LLDP Mode: NONE, LR Priority: 1024
184
185 RX: Pkts(5073645) Bytes(848299459) Errs(0) Drops(0) Stalls(0)
186 TX: Pkts(9923625) Bytes(968741778) Errs(0) Drops(0) Stalls(0)
187 Bandwidth thresholds are not set.
188
189 Done

```

4. In the show interface command's output, verify that all the interfaces are enabled and the status of every interface is shown as UP/UP.

Notes:

>

>- The interface status is displayed as UP/UP only if the cables are connected to the interfaces.

>

>- If you do not have an SFP+ transceiver for every port, verify the interfaces in stages. After checking the first set of interfaces, unplug the SFP+ transceivers and plug them in to the next set of ports.

5. Run the following command for each of the interfaces that are not in the UP/UP state:

```

1 > enable interface 50/1
2 Done
3 > enable interface 50/2
4 Done
5 > enable interface 50/3
6 Done
7 > enable interface 50/4
8 Done

```

Where x is the new interface number

6. Run the following command to verify that the status of the power supplies is normal:

```
stat system -detail
```

Example

```

1 > stat system -detail
2
3 NetScaler Executive View
4
5 System Information:
6 Up since          Sat Dec  5 04:17:29 2020
7 Up since(Local)  Sat Dec  5 04:17:29 2020
8 Memory usage (MB)          4836
9 InUse Memory (%)          4.08
10 Number of CPUs           13
11
12 System Health Statistics (Standard):
13 CPU 0 Core Voltage (Volts)          1.80
14 CPU 1 Core Voltage (Volts)          1.80
15 Main 3.3 V Supply Voltage          3.35
16 Standby 3.3 V Supply Voltage        3.23
17 +5.0 V Supply Voltage              5.00
18 +12.0 V Supply Voltage             12.06
19 Battery Voltage (Volts)            3.02
20 Intel CPU Vtt Power(Volts)         0.00
21 5V Standby Voltage(Volts)          4.95
22 Voltage Sensor2(Volts)            0.00
23 CPU Fan 0 Speed (RPM)              3500
24 CPU Fan 1 Speed (RPM)              3600
25 System Fan Speed (RPM)             3600
26 System Fan 1 Speed (RPM)           3600
27 System Fan 2 Speed (RPM)           3500
28 CPU 0 Temperature (Celsius)        37
29 CPU 1 Temperature (Celsius)        47
30 Internal Temperature (Celsius)     26
31 Power supply 1 status              NORMAL
32 Power supply 2 status              NORMAL
33 Power supply 3 status              NOT SUPPORTED
34 Power supply 4 status              NOT SUPPORTED
35
36 System Disk Statistics:
37 /flash Size (MB)                  23801
38 /flash Used (MB)                  7009
39 /flash Available (MB)             14887
40 /flash Used (%)                   32
41 /var Size (MB)                    341167
42 /var Used (MB)                    56502
43 /var Available (MB)               257371
44 /var Used (%)                     18
45
46 System Health Statistics(Auxiliary):
47 Voltage 0 (Volts)                 1.20
48 Voltage 1 (Volts)                 1.20
49 Voltage 2 (Volts)                 1.20
50 Voltage 3 (Volts)                 1.20
51 Voltage 4 (Volts)                 1.54
52 Voltage 5 (Volts)                 0.00
53 Voltage 6 (Volts)                 0.00

```

```
54 Voltage 7 (Volts) 0.00
55 Fan 0 Speed (RPM) 3600
56 Fan 1 Speed (RPM) 0
57 Fan 2 Speed (RPM) 0
58 Fan 3 Speed (RPM) 0
59 Temperature 0 (Celsius) 24
60 Temperature 1 (Celsius) 30
61 Temperature 2 (Celsius) 0
62 Temperature 3 (Celsius) 0
63 Done
```

7. Run the following command to generate a tar of system configuration data and statistics:

```
show techsupport
```

Example

```
1 > show techsupport
2
3 showtechsupport data collector tool - $Revision$!
4 NetScaler version 13.0
5 The NS IP of this box is 10.217.206.43
6 This is not HA configuration
7 Copying selected configuration files ....
8 Running shell commands ....
9 Running CLI show commands ....
10 Collecting ns running configuration....
11 Collecting running gslb configuration....
12 Running CLI stat commands ....
13 Running vtysh commands ....
14 Copying newslog files ....
15 Copying core files from /var/core ....
16 Copying core files from /var/crash ....
17 Copying GSLB location database files ....
18 Copying GSLB auto sync log files ....
19 Copying Safenet Gateway log files ....
20 Copying messages, ns.log, dmesg and other log files ....
21 Creating archive ....
22 /var/tmp/support/support.tgz ---- points to ---> /var/tmp/support
   /collector_P_10.217.206.43_5Dec2020_05_32.tar.gz
23
24 showtechsupport script took 1 minute(s) and 17 second(s) to
   execute.
25 Done
```

Note

The output of the command is available in the `/var/tmp/support/collector_<IP_address>_P_<date>.tar.gz` file. Copy this file to another computer for future reference. The output of the command might be helpful when you want to contact Citrix technical support.

8. At the command line interface, switch to the shell prompt. Type: `shell`

Example

```
1 > shell
2 Copyright (c) 1992-2013 The FreeBSD Project.
3 Copyright (c) 1979, 1980, 1983, 1986, 1988, 1989, 1991, 1992,
  1993, 1994
4   The Regents of the University of California. All rights
  reserved.
5
6 root@ns#
```

9. Run the following command to verify the number of Cavium cards available depending upon your appliance:

```
root@ns# grep "memory"/var/nslog/dmesg.boot
```

Example

```
1 root@ns# grep "memory" /var/nslog/dmesg.boot
2 real memory = 139586437120 (133120 MB)
3 avail memory = 132710871040 (126562 MB)
4 root@ns#
```

10. Run the following command to verify the number of CPU cores depending upon your appliance:

```
root@ns# grep "cpu"/var/nslog/dmesg.boot
```

Example

```
1 root@ns# grep "cpu" /var/nslog/dmesg.boot
2 cpu0 (BSP): APIC ID: 0
3 cpu1 (AP): APIC ID: 2
4 cpu2 (AP): APIC ID: 4
5 cpu3 (AP): APIC ID: 6
6 cpu4 (AP): APIC ID: 8
7 cpu5 (AP): APIC ID: 10
8 cpu6 (AP): APIC ID: 12
9 cpu7 (AP): APIC ID: 14
10 cpu8 (AP): APIC ID: 16
11 cpu9 (AP): APIC ID: 18
12 cpu10 (AP): APIC ID: 20
13 cpu11 (AP): APIC ID: 22
14 cpu12 (AP): APIC ID: 24
15 cpu13 (AP): APIC ID: 26
16 cpu14 (AP): APIC ID: 28
17 cpu15 (AP): APIC ID: 30
18 cpu0: <ACPI CPU> on acpi0
19 cpu1: <ACPI CPU> on acpi0
20 cpu2: <ACPI CPU> on acpi0
21 cpu3: <ACPI CPU> on acpi0
22 cpu4: <ACPI CPU> on acpi0
23 cpu5: <ACPI CPU> on acpi0
24 cpu6: <ACPI CPU> on acpi0
25 cpu7: <ACPI CPU> on acpi0
```



```

26 cpu8: <ACPI CPU> on acpi0
27 cpu9: <ACPI CPU> on acpi0
28 cpu10: <ACPI CPU> on acpi0
29 cpu11: <ACPI CPU> on acpi0
30 cpu12: <ACPI CPU> on acpi0
31 cpu13: <ACPI CPU> on acpi0
32 cpu14: <ACPI CPU> on acpi0
33 cpu15: <ACPI CPU> on acpi0
34 est0: <Enhanced SpeedStep Frequency Control> on cpu0
35 p4tcc0: <CPU Frequency Thermal Control> on cpu0
36 est1: <Enhanced SpeedStep Frequency Control> on cpu1
37 p4tcc1: <CPU Frequency Thermal Control> on cpu1
38 est2: <Enhanced SpeedStep Frequency Control> on cpu2
39 p4tcc2: <CPU Frequency Thermal Control> on cpu2
40 est3: <Enhanced SpeedStep Frequency Control> on cpu3
41 p4tcc3: <CPU Frequency Thermal Control> on cpu3
42 est4: <Enhanced SpeedStep Frequency Control> on cpu4
43 p4tcc4: <CPU Frequency Thermal Control> on cpu4
44 est5: <Enhanced SpeedStep Frequency Control> on cpu5
45 p4tcc5: <CPU Frequency Thermal Control> on cpu5
46 est6: <Enhanced SpeedStep Frequency Control> on cpu6
47 p4tcc6: <CPU Frequency Thermal Control> on cpu6
48 est7: <Enhanced SpeedStep Frequency Control> on cpu7
49 p4tcc7: <CPU Frequency Thermal Control> on cpu7
50 est8: <Enhanced SpeedStep Frequency Control> on cpu8
51 p4tcc8: <CPU Frequency Thermal Control> on cpu8
52 est9: <Enhanced SpeedStep Frequency Control> on cpu9
53 p4tcc9: <CPU Frequency Thermal Control> on cpu9
54 est10: <Enhanced SpeedStep Frequency Control> on cpu10
55 p4tcc10: <CPU Frequency Thermal Control> on cpu10
56 est11: <Enhanced SpeedStep Frequency Control> on cpu11
57 p4tcc11: <CPU Frequency Thermal Control> on cpu11
58 est12: <Enhanced SpeedStep Frequency Control> on cpu12
59 p4tcc12: <CPU Frequency Thermal Control> on cpu12
60 est13: <Enhanced SpeedStep Frequency Control> on cpu13
61 p4tcc13: <CPU Frequency Thermal Control> on cpu13
62 est14: <Enhanced SpeedStep Frequency Control> on cpu14
63 p4tcc14: <CPU Frequency Thermal Control> on cpu14
64 est15: <Enhanced SpeedStep Frequency Control> on cpu15
65 p4tcc15: <CPU Frequency Thermal Control> on cpu15
66 root@ns#

```

11. Run the following command to verify that the /var drive is mounted as /dev/ ar0s1a:
root@ns# df -h

Example

```

1 root@ns# df -h
2 Filesystem      Size    Used    Avail Capacity  Mounted on
3 /dev/md0        422M   404M    9.1M    98%      /
4 devfs           1.0k    1.0k     0B    100%     /dev
5 procfs          4.0k    4.0k     0B    100%     /proc
6 /dev/ar0s1a     23G    6.9G    14G     32%     /flash

```

```
7 /dev/ar0s1e 333G 32G 274G 10% /var
8 root@ns#
```

12. Type the following command to run the `ns_hw_err.bash` script, which checks for latent hardware errors: `root@ns`

```
# ns_hw_err.bash
```

Example

```
1 root@ns# ns_hw_err.bash
2 NetScaler NS13.0: Build 71.3602.nc, Date: Nov 12 2020, 07:26:41
  (64-bit)
3 platform: serial 4VCX9CUFN6
4 platform: sysid 520400 - NSMPX-15000-50G 16*CPU+128GB+4*MLX(50)+8*
  F1X+2*E1K+2*2-CHIP COL 8955
5 HDD MODEL: ar0: 434992MB <Intel MatrixRAID RAID1> status: READY
6
7 Generating the list of newslog files to be processed...
8 Generating the events from newslog files...
9 Checking for HDD errors...
10 Checking for HDD SMART errors...
11 Checking for Flash errors...
12 Checking for Mega Raid Controller errors...
13 Checking for SSL errors...
14 Dec 5 06:00:31 <daemon.err> ns monit[996]: 'safenet_gw' process
  is not running
15 Checking for BIOS errors...
16 Checking for SMB errors...
17 Checking for MotherBoard errors...
18 Checking for CMOS errors...
19 License year: 2020: OK
20 Checking for SFP/NIC errors...
21 Dec 5 06:02:32 <daemon.err> ns monit[996]: 'safenet_gw' process
  is not running
22 Checking for Firmware errors...
23 Checking for License errors...
24 Checking for Undetected CPUs...
25 Checking for DIMM flaps...
26 Checking for Memory Channel errors...
27 Checking for LOM errors...
28 Checking the Power Supply Errors...
29 Checking for Hardware Clock errors...
30 Script Done.
31 root@ns#
```

13. **Important:** Physically disconnect all ports except the LOM port, including the management port, from the network.

14. At the shell prompt, switch to the ADC command line. Type: `exit`

Example

```
1 root@ns# exit
2 logout
3 Done
```

15. Run the following command to shut down the appliance. You are asked if you want to completely stop the ADC. Type: `shutdown -p now`

Example

```
1 > shutdown -p now
2 Are you sure you want to completely stop NetScaler (Y/N)? [N]:y
3 Done
4 > Dec 5 06:09:11 <auth.notice> ns shutdown: power-down by root:
5 Dec 5 06:09:13 <auth.emerg> ns init: Rebooting via init mechanism
6 Dec 5 06:09:13 <syslog.err> ns syslogd: exiting on signal 15
7 Dec 5 06:09:13 aslearn[1662]: before pthread_join(), task name:
  Aslearn_Packet_Loop_Task
8 Dec 5 06:09:15 aslearn[1662]: Exiting function ns_do_logging
9 Dec 5 06:09:15 aslearn[1662]: before pthread_join(), task name:
  Aslearn_WAL_Cleanup_Task
10 Dec 5 06:09:15 aslearn[1662]: before pthread_join(), task name:
  Aslearn_HA_Primary_Task
11 Dec 5 06:09:15 aslearn[1662]: 1662 exiting gracefully
12 Dec 5 06:09:18 [1672]: nsnet_tcpipconnect: connect() failed;
  returned -1 errno=61
13 qat0: qat_dev0 stopped 12 acceleration engines
14 pci4: Resetting device
15 qat1: qat_dev1 stopped 12 acceleration engines
16 pci6: Resetting device
17 qat2: qat_dev2 stopped 12 acceleration engines
18 pci132: Resetting device
19 qat3: qat_dev3 stopped 12 acceleration engines
20 pci134: Resetting device
21 Dec 5 06:09:33 init: some processes would not die; ps axl advised
22 reboot initiated by init with parent kernel
23 Waiting (max 60 seconds) for system process `vnlru' to stop...done
24 Waiting (max 60 seconds) for system process `bufdaemon' to stop...
  done
25 Waiting (max 60 seconds) for system process `syncer' to stop...
26 Syncing disks, vnodes remaining...0 0 0 done
27 All buffers synced.
28 Uptime: 1h53m18s
29 ixl_shutdown: lldp start 0
30 ixl_shutdown: lldp start 0
31 ixl_shutdown: lldp start 0
32 ixl_shutdown: lldp start 0
33 usb0: Controller shutdown
34 uhub0: at usb0, port 1, addr 1 (disconnected)
35 usb0: Controller shutdown complete
36 usb1: Controller shutdown
37 uhub1: at usb1, port 1, addr 1 (disconnected)
38 ugen1.2: <vendor 0x8087> at usb1 (disconnected)
39 uhub3: at uhub1, port 1, addr 2 (disconnected)
```

```

40 ugen1.3: <FTDI> at usb1 (disconnected)
41 uftdi0: at uhub3, port 1, addr 3 (disconnected)
42 ugen1.4: <vendor 0x1005> at usb1 (disconnected)
43 umass0: at uhub3, port 3, addr 4 (disconnected)
44 (da0:umass-sim0:0:0:0): lost device - 0 outstanding, 0 refs
45 (da0:umass-sim0:0:0:0): removing device entry
46 usb1: Controller shutdown complete
47 usb2: Controller shutdown
48 uhub2: at usb2, port 1, addr 1 (disconnected)
49 ugen2.2: <vendor 0x8087> at usb2 (disconnected)
50 uhub4: at uhub2, port 1, addr 2 (disconnected)
51 ugen2.3: <vendor 0x0557> at usb2 (disconnected)
52 uhub5: at uhub4, port 7, addr 3 (disconnected)
53 ugen2.4: <vendor 0x0557> at usb2 (disconnected)
54 ukbd0: at uhub5, port 1, addr 4 (disconnected)
55 ums0: at uhub5, port 1, addr 4 (disconnected)
56 usb2: Controller shutdown complete
57 ixl_shutdown: lldp start 0
58 ixl_shutdown: lldp start 0
59 ixl_shutdown: lldp start 0
60 ixl_shutdown: lldp start 0
61 acpi0: Powering system off

```

Upgrade the appliance

To upgrade the appliance, follow these steps:

1. Power off the ADC appliance.
2. Locate two solid-state drives (SSDs) on the back of the appliance in slot #1 and slot #2, as shown in the following figure:

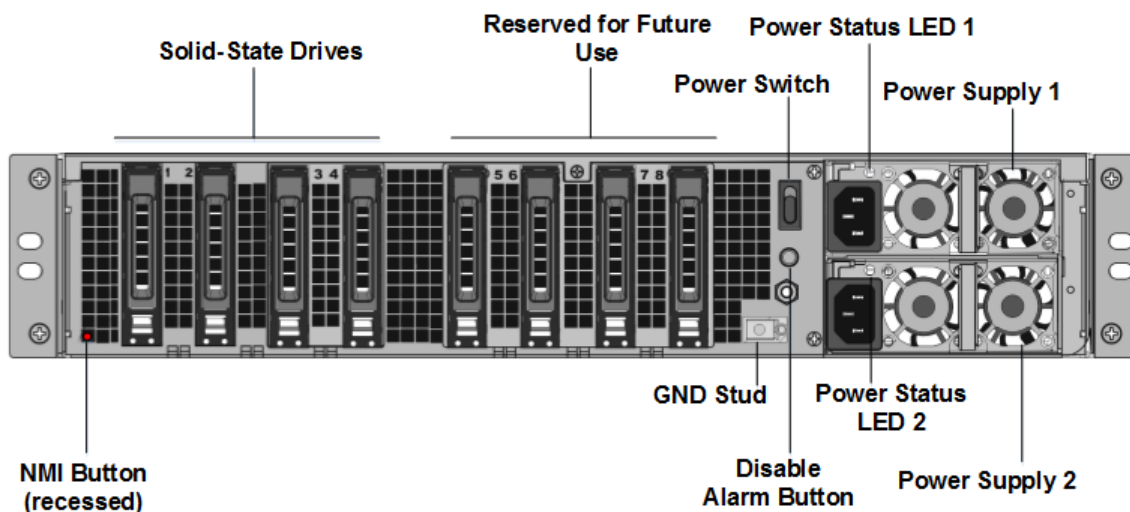

3. Verify that the replacement solid-state drives (SSDs) are the ones required for your ADC model. The conversion requires minimum of four SSDs. The NetScaler label is on the top of one of the

SSDs. The SSD is pre-populated with a new version of the BIOS and a recent build of the required NetScaler SDX Management Service. This SSD must be installed in slot # 1.

4. Remove the SSDs by pushing the safety latch of the drive cover down while pulling the drive handle.
5. On the new NetScaler certified SSD drive, open the drive handle completely to the left. Then insert the new drive into the slot #1 as far as possible.
6. To seat the drive, close the handle flush with the rear side of the appliance so that the drive locks securely into the slot.

Important: The orientation of the SSD is important. When you insert the drive, make sure that the NetScaler product label is at the side.

7. Insert a second NetScaler certified SSD, which matches the capacity of the SSD in slot #1, in slot # 2.

Note: If the license of your appliance is 14040 40G, 14060 40G, 14080 40G, insert more blank NetScaler certified SSDs in slots #3, #4, #5, and #6.

NetScaler SDX Model	Included Virtual Instances	Platform Maximum	SSDs included on base model	Extra SSDs for max instances
SDX 15020/SDX 15020-50G	5	55	Two 240 GB RAID-supported removable boot solid-state drives (SSDs), (slots 1 and 2). Two 240 GB RAID-supported removable storage repositories (slots 3 and 4 paired) SSDs, and four 480 GB storage repositories (slots 5–6 paired and 7–8 paired) SSDs.	NA

SDX 15030/SDX 15030-50G	20	55	Two 240 GB RAID-supported removable boot solid-state drives (SSDs), (slots 1 and 2). Two 240 GB RAID-supported removable storage repositories (slots 3 and 4 paired) SSDs, and four 480 GB storage repositories (slots 5–6 paired and 7– 8 paired) SSDs.	NA
----------------------------	----	----	--	----

Important

Mixing and matching of old and new SSDs is not supported. SSDs in slot #1 and slot #2, which constitute the first RAID pair (local storage), must be of the same size and type. Similarly, SSDs in slot #3 and slot #4, which constitute the second RAID pair (VPX storage), must be of the same size and type. Use only drives that are part of the provided conversion kit.

8. Disconnect all network cables from the data ports and the management ports.
9. Start the ADC appliance. For instructions, see “Switching on the Appliance” in Installing the Hardware.

The conversion process can run for approximately 30 minutes, during which you must not power cycle the appliance. The entire conversion process might not be visible on the console and might appear to be unresponsive.

The conversion process updates the BIOS, installs the Citrix Hypervisor and the Management Service Operating system. It also copies the NetScaler VPX image to the SSD for instance provisioning, and forms the Raid1 pair.

Note: The serial number of the appliance remains the same.

10. Keep the console cable attached during the conversion process. Allow the process to complete, at which point the SDX login: prompt appears.

11. During the conversion process the LOM port connection might be lost as it resets the IP address to the default value of 192.168.1.3. The conversion status output is available on the VGA monitor.
12. The default credentials for the Citrix Hypervisor are changed to root/nsroot after the appliance is converted from an MPX to SDX. If this password does not work, try typing nsroot/the serial number of the appliance. The serial number bar code is available at the back of the appliance, and is also available in the output of the `show hardware` command.
13. To make sure that the conversion is successful, verify that the FVT result indicates success. Run the following command: `tail /var/log/fvt/fvt.log`

Reconfigure the converted appliance

After the conversion process, the appliance no longer has its previous working configuration. Therefore, you can access the appliance through a web browser only by using the default IP address: 192.168.100.1/16. Configure a computer on network 192.168.0.0 and connect it directly to the appliance's management port (0/1) with a cross-over Ethernet cable. Alternately, access the NetScaler SDX appliance through a network hub by using a straight through Ethernet cable. Use the default credentials to log on, and then do the following:

1. Select the Configuration tab.
2. Verify that the System Resource section displays the accurate number of CPU cores, SSL cores, and the total memory for your NetScaler SDX appliance.
3. Select the **System** node and, under **Set Up Appliance**, click **Network Configuration** to modify the network information of the Management Service.
4. In the **Modify Network Configuration** dialog box, specify the following details:
 - Interface*—The interface through which clients connect to the Management Service. Possible values: 0/1, 0/2. Default: 0/1.
 - Citrix Hypervisor IP Address*—The IP address of Citrix Hypervisor.
 - Management Service IP Address*—The IP address of the Management Service.
 - Netmask*—The subnet mask for the subnet in which the SDX appliance is located.
 - Gateway*—The default gateway for the network.
 - DNS Server—The IP address of the DNS server.

*A mandatory parameter

5. Click **OK**. Connection to the Management Service is lost as the network information was changed.
6. Connect the NetScaler SDX appliance's management port 0/1 to a switch to access it through the network. Browse to the IP address used earlier and log on with the default credentials.

7. Apply the new licenses. For instructions, see [SDX Licensing Overview](#).
8. Navigate to **Configuration > System** and, in the **System Administration** group, click **Reboot Appliance**. Click **Yes** to confirm. You are now ready to provision the VPX instances on the NetScaler SDX appliance. For instructions, see [Provisioning NetScaler instances](#).

Migrate the configuration of a NetScaler instance across SDX appliances

May 23, 2024

Before you migrate the NetScaler instance configuration to a new SDX appliance, you must first set up the new SDX appliance.

The following table lists the device names involved in the migration process:

Term	Description
SDX-OLD-A1, SDX-OLD-A2	Name of the old SDX platform
SDX-NEW-A1, SDX-NEW-A2	Name of the new SDX platform
VPX-OLD-A1, VPX-OLD-A2	Name of the VPX instance hosted on the old SDX platform
VPX-NEW-A1, VPX-NEW-A2	Name of the VPX instance hosted on the new SDX platform

The following images explain the migration process, showing the current, interim, and final states for the High Availability (HA) configurations.

Figure 1. Current state



Figure 2. Interim state

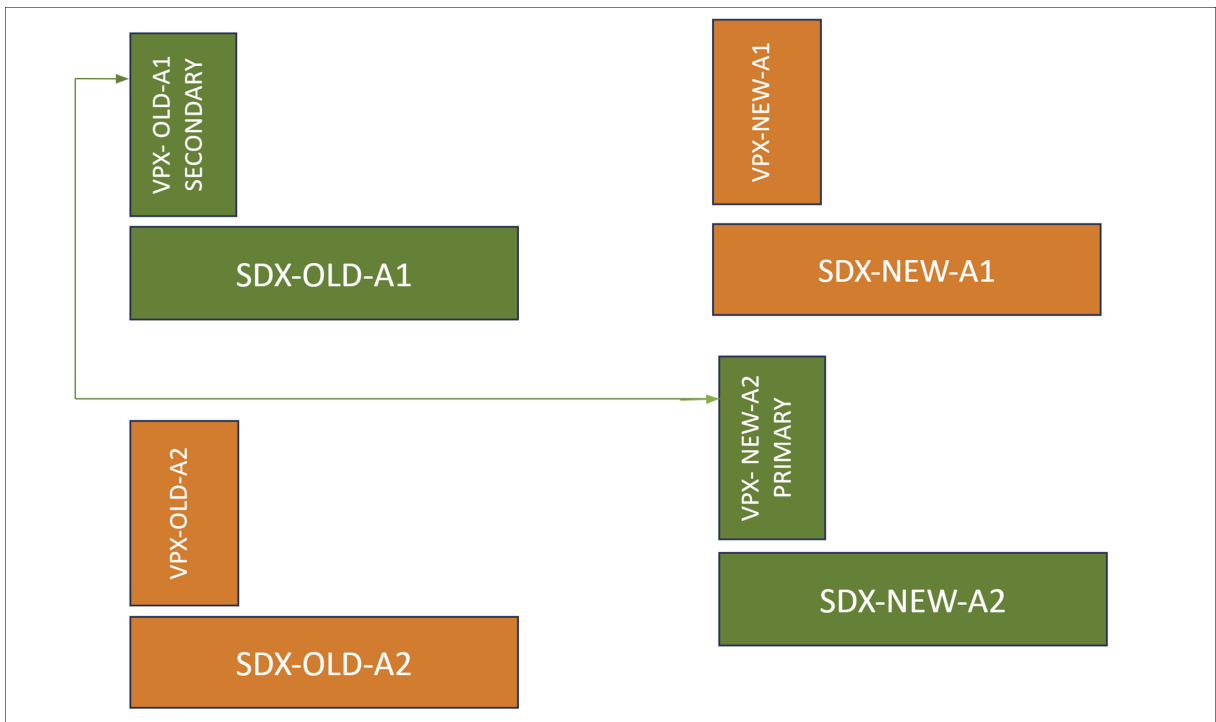
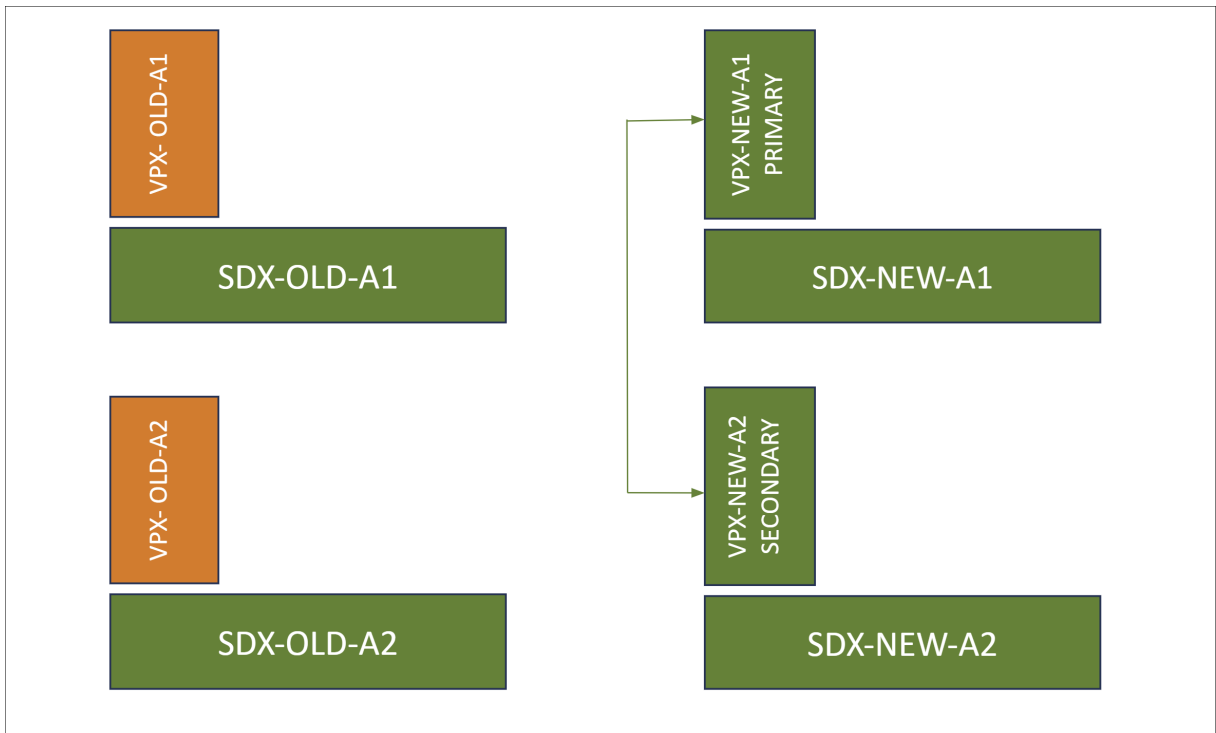

Figure 3. Desired state



The following table explains the color legends used in the diagram:

Color legends	Description
Green	Represents the platforms and instances in their current or desired state.
Orange	Represents the platforms and instances undergoing transition or pending migration.

Prerequisites

- Upgrade the new SDX appliance (SDX-NEW-A2) to the same build version as the older one. If the build on the old SDX appliance is not supported on the new SDX, first upgrade the older SDX appliance to a build that is supported on the new SDX.
- In the new SDX appliance (SDX-NEW-A2), complete the [initial configuration](#), including setting up usernames, passwords, IP addresses, and gateway configurations.
- If any specific configurations exist on the old SDX appliances that need to be replicated, use the Management Service to configure settings such as channel creation, mtu settings, and admin profiles on the new SDX appliance.
- Provision a NetScaler instance (VPX-NEW-A2) on the new SDX appliance (SDX-NEW-A2) with the same build and configuration as the older one. For more information, see [Provision NetScaler](#)

[instance on SDX appliance.](#)

Supported migration scenarios

This migration applies to the following scenarios:

- High Availability (HA) configuration
- Standalone deployments
- Migrating to an identical SDX platform
- Migrating to a different SDX platform

Notes:

- This migration process doesn't support migrating from SDX to third-party hypervisor hosted VPX instances.
- These outlined steps are validated for migrating SDX platforms from SDX 14000 to 15000, SDX 14000 to 16000, and SDX 22000 to 15000. The same steps are also applicable to other SDX platforms.

The different scenarios are explained below:

Case 1: No channel and same interface speed and numbering If the old VPX instance (VPX-OLD-A2) is configured with interfaces 10/1, 10/2, ..., 10/n, the new VPX instance (VPX-NEW-A2) must replicate this configuration precisely.

Case 2: No channel and different interface speed or numbering If the old VPX instance (VPX-OLD-A2) is configured with interfaces 10/1 and 10/2, and the new VPX instance (VPX-NEW-A2) is configured with interfaces 10/3 and 10/4. Alternatively, the new VPX instance (VPX-NEW-A2) might use interfaces 25/1 and 25/2.

Case 3: Same channel numbering If the old VPX instance (VPX-OLD-A2) is configured with channels LA/1, LA/2, ..., LA/n, then the new VPX instance (VPX-NEW-A2) must replicate this configuration precisely. The underlying member interface numbering or speed does not affect this requirement.

Case 4: Different channel numbering If the old VPX instance (VPX-OLD-A2) is configured with channels LA/1 and LA/2, while the new VPX instance (VPX-NEW-A2) is configured with channels LA/3 and LA/4.

Phases in migration

Phase 1: Break HA (if applicable) and remove the secondary VPX

If HA is enabled, you must break the HA configuration and remove the secondary VPX (VPX-OLD-A2) from the HA setup.

1. Break the HA configuration

- a) Log on to the primary VPX instance (VPX-OLD-A1) CLI.
- b) To set the HA status on VPX-OLD-A1 to stay as the primary node, type:

```
1 set ha node -hastatus STAYPRIMARY
```

- c) To disable the HA sync status on the primary node (VPX-OLD-A1), type:

```
1 set ha node -haSync DISABLED
```

2. Remove the secondary VPX from the HA pair

- a) Log on to the secondary VPX instance (VPX-OLD-A2) CLI.
- b) To set the HA status on VPX-OLD-A2 to stay as the secondary node, type:

```
1 set ha node -hastatus STAYSECONDARY
```

- c) Remove VPX-OLD-A2 from the HA pair to break the ha configuration. Identify the node ID for VPX-OLD-A2 and run the following command:

```
1 rm ha node <node_id>
```

Phase 2: Form an HA pair between the old primary VPX and the new VPX

To establish an HA pair between the old primary VPX (VPX-OLD-A1) and the new VPX (VPX-NEW-A2):

1. On the CLI of the old primary VPX (VPX-OLD-A1), type:

```
1 add ha node 1 <IP address of VPX-NEW-A2>
```

2. On the CLI of the new VPX (VPX-NEW-A2), type:

```
1 add ha node 1 <IP address of VPX-OLD-A1>
```

Phase 3: Migrate VPX configuration

On the primary VPX (VPX-OLD-A1), enable HA sync using the following command:

```
1 set ha node -haSync ENABLED
```

Phase 4 (optional): Additional steps required for case 2 and case 4

Perform the following steps to address specific scenarios in case 2 (no channel and different interface speed or numbering) and case 4 (different channel numbering) migration.

On the new secondary VPX (VPX-NEW-A2):

1. Check the log file at `/var/nssynclog/sync_batch_status.log` for errors.
2. The interface-related settings might generate errors. Manually fix the `bind vlan` and `set interface` configurations.
3. If any other errors are found, manually address them.
4. Save the configuration using either the `save config` or `save ns config -all` command.

Notes:

Before you initiate the traffic failover to the new VPX on the new SDX appliance, ensure the following:

- Verify that HA sync is enabled.
- Validate the configuration of the current secondary VPX (VPX-NEW-A2) using the command `show ns runningconfig`.
- Check for errors in the log file located at `/var/nssynclog/sync_batch_status.log` on the secondary node.

Phase 5: Force failover to migrate the traffic to the new VPX on the new SDX appliance

To initiate a forced failover to shift traffic to the new VPX (VPX-NEW-A2) hosted on the new SDX appliance, perform the following steps:

1. On VPX-OLD-A1, to enable the HA pair, type:

```
1 set ha node -haStatus ENABLED
```

Here, VPX-OLD-A1 becomes active in the HA pair.

2. To force the failover of traffic to the new VPX (VPX-NEW-A2), type:

```
1 force ha failover
```

VPX-NEW-A2 becomes the primary node handling the incoming traffic.

In the transition from the previous SDX platform, SDX-OLD-A2, to the new SDX platform, SDX-NEW-A2, the VPX-NEW-A2 on SDX-NEW-A2 is now the primary node and manages traffic. These steps are also applicable to replace SDX-OLD-A1 with the new SDX platform, SDX-NEW-A1.

Troubleshooting

August 23, 2024

Following is the list of troubleshooting articles for NetScaler SDX hardware issues:

1. Troubleshooting NetScaler Power Supply Issues: <https://support.citrix.com/article/CTX202340>
2. Troubleshooting NetScaler Small Form Pluggable (SFP) Issues: <https://support.citrix.com/article/CTX236074>
3. Troubleshooting NetScaler SSL Card Issues: <https://support.citrix.com/article/CTX236094>
4. Troubleshooting NetScaler LOM GUI issues: https://support.citrix.com/s/article/CTX477557-mpxsdx-series-910016000-gui-lom-access-to-configuration-settings-are-readonly?language=en_US



© 2024 Cloud Software Group, Inc. All rights reserved. This document is subject to U.S. and international copyright laws and treaties. No part of this document may be reproduced in any form without the written authorization of Cloud Software Group, Inc. This and other products of Cloud Software Group may be covered by registered patents. For details, please refer to the Virtual Patent Marking document located at <https://www.cloud.com/legal>. Citrix, the Citrix logo, NetScaler, and the NetScaler logo and other marks appearing herein are either registered trademarks or trademarks of Cloud Software Group, Inc. and/or its subsidiaries in the United States and/or other countries. Other marks are the property of their respective owner(s) and are mentioned for identification purposes only. Please refer to Cloud SG's Trademark Guidelines and Third Party Trademark Notices (<https://www.cloud.com/legal>) for more information.